



# U74LVC02A

**CMOS IC**

## QUAD 2-INPUT POSITIVE-NOR GATE

### DESCRIPTION

The **U74LVC02A** is a quad 2-input positive-NOR gate which performs the function  $Y=A+B$  or  $Y=\overline{A \times B}$ . It is designed for 1.65V to 3.6V operation.

### FEATURES

- \* Wide supply voltage range from 1.65V to 3.6V
- \* Max  $t_{pd}$  of 4.4ns at 3.3V
- \* Up to 5.5V inputs accept voltages
- \* Low power consumption,  $I_{CC}=10\mu A$  (Max.)
- \*  $\pm 24$  mA output driver at 3V
- \* Typical  $V_{OLP}$  (Output Ground Bounce) < 0.8V,  $V_{CC}=3.3V$ ,  $T_A=25^\circ C$
- \* Typical  $V_{OHV}$  (Output  $V_{OH}$  undershoot) > 2V,  $V_{CC}=3.3V$ ,  $T_A=25^\circ C$

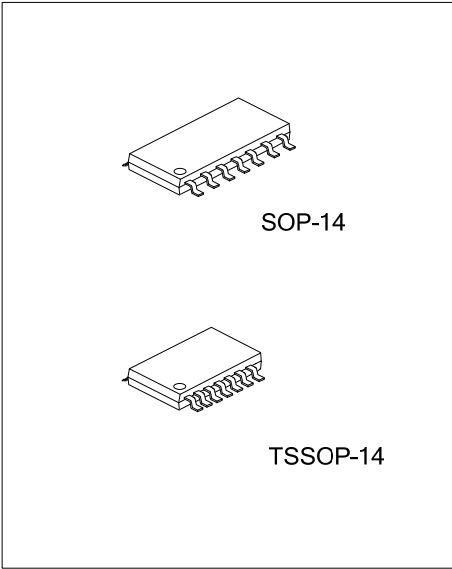

### ORDERING INFORMATION

Ordering Number		Package	Packing
Lead Free	Halogen Free		
U74LVC02AL-S14-R	U74LVC02AG-S14-R	SOP-14	Tape Reel
U74LVC02AL-P14-R	U74LVC02AG-P14-R	TSSOP-14	Tape Reel

<p>U74LVC02AG-S14-R</p> <p>(1) Packing Type (2) Package Type (3) Green Package</p>	<p>(1) R: Tape Reel (2) S14: SOP-14, P14: TSSOP-14 (3) G: Halogen Free and Lead Free, L: Lead Free</p>
--	--

### MARKING

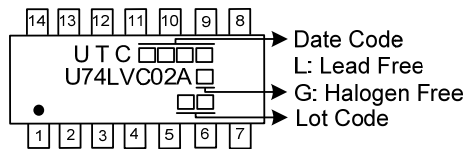

■ PIN CONFIGURATION

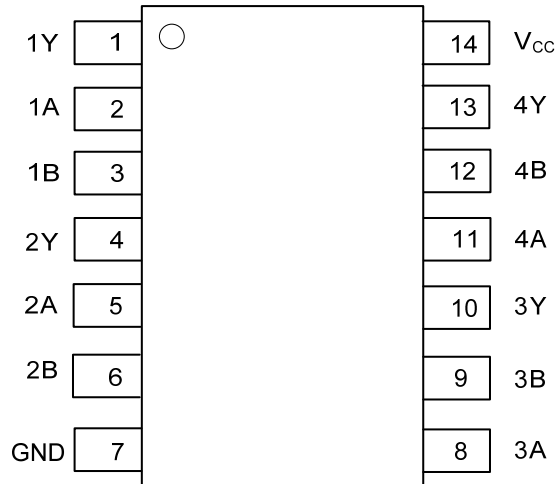

■ PIN DESCRIPTION

PIN	SYMBOL	FUNCTION
2, 5, 8, 11	1A-4A	Data inputs
3, 6, 9, 12	1B-4B	Data inputs
1, 4, 10, 13	1Y-4Y	Data outputs
7	GND	Ground (0V)
14	V <sub>CC</sub>	Positive supply voltage

■ FUNCTION TABLE (each gate)

INPUTS		OUTPUT
A	B	Y
L	L	H
L	H	L
H	L	L
H	H	L

■ LOGIC SYMBOL (one gate)

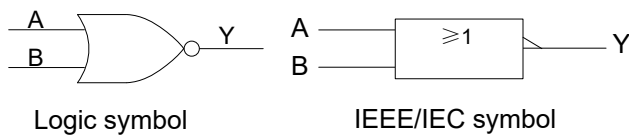

■ ABSOLUTE MAXIMUM RATING (Unless otherwise specified)

PARAMETER	SYMBOL	RATINGS	UNIT
Supply Voltage	$V_{CC}$	-0.5~6.5	V
Input Voltage	$V_{IN}$	-0.5~6.5	V
Output Voltage (any output in the high or low state)	$V_{OUT}$	-0.5~ $V_{CC}$ +0.5	V
Input Clamp Current	$I_{IK}$	-50	mA
Output Clamp Current	$I_{OK}$	-50	mA
Output Current	$I_{OUT}$	±50	mA
$V_{CC}$ or GND Current	$I_{CC}$	±100	mA
Storage Temperature	$T_{STG}$	-65 ~ +150	°C

Note: 1. The input and output voltage ratings may be exceeded if the input and output current ratings are observed.  
 2. Absolute maximum ratings are those values beyond which the device could be permanently damaged.  
 Absolute maximum ratings are stress ratings only and functional device operation is not implied.

■ THERMAL DATA

PARAMETER	SYMBOL	RATINGS	UNIT
Junction to Ambient	SOP-14	86	°C/W
	TSSOP-14	113	°C/W

■ RECOMMENDED OPERATING COMDITIONS (Unless otherwise specified)

PARAMETER	SYMBOL	CONDITIONS	MIN	TYP	MAX	UNIT
Supply Voltage	$V_{CC}$	Operating	1.65		3.6	V
		Data retention only	1.5			
High-Level Input Voltage	$V_{IH}$	$V_{CC} = 1.65V$ to $1.95V$	$0.65 \times V_{CC}$			V
		$V_{CC} = 2.3V$ to $2.7V$	1.7			
		$V_{CC} = 2.7V$ to $3.6V$	2			
Low-Level Input Voltage	$V_{IL}$	$V_{CC} = 1.65V$ to $1.95V$			$0.35 \times V_{CC}$	V
		$V_{CC} = 2.3V$ to $2.7V$			0.7	
		$V_{CC} = 2.7V$ to $3.6V$			0.8	
Input Voltage	$V_{IN}$		0		5.5	V
Output Voltage	$V_{OUT}$		0		$V_{CC}$	V
High-level Output Current	$I_{OH}$	$V_{CC}=1.65V$			-4	mA
		$V_{CC}=2.3V$			-8	
		$V_{CC}=2.7V$			-12	
		$V_{CC}=3V$			-24	
Low-level Output Current	$I_{OL}$	$V_{CC}=1.65V$			4	mA
		$V_{CC}=2.3V$			8	
		$V_{CC}=2.7V$			12	
		$V_{CC}=3V$			24	
Input Transition Rise or Fall Rate	$\Delta t/\Delta v$	$V_{CC}=1.2$ to $2.7V$			20	ns/V
		$V_{CC}=2.7$ to $3.6V$			10	
Operating Temperature	$T_A$		-40		+125	°C

■ ELECTRICAL CHARACTERISTICS (Unless otherwise specified)

PARAMETER	SYMBOL	TEST CONDITIONS	MIN	TYP	MAX	UNIT
High-Level Output Voltage	$V_{OH}$	$I_{OH}=-100\ \mu A, V_{CC}=1.65V\sim 3.6V$	$V_{CC}-0.2$			V
		$I_{OH}=-4\ mA, V_{CC}=1.65V$	1.2			
		$I_{OH}=-8\ mA, V_{CC}=2.3V$	1.7			
		$I_{OH}=-12\ mA, V_{CC}=2.7V$	2.2			
		$I_{OH}=-12\ mA, V_{CC}=3V$	2.4			
		$I_{OH}=-24\ mA, V_{CC}=3V$	2.2			
Low-Level Output Voltage	$V_{OL}$	$I_{OL}=100\ \mu A, V_{CC}=1.65V\sim 3.6V$			0.2	V
		$I_{OL}=4\ mA, V_{CC}=1.65V$			0.45	
		$I_{OL}=8\ mA, V_{CC}=2.3V$			0.7	
		$I_{OL}=12\ mA, V_{CC}=2.7V$			0.4	
		$I_{OL}=24\ mA, V_{CC}=3V$			0.55	
Input Leakage Current	$I_{I(LEAK)}$	$V_{IN}=5.5V\ \text{or}\ GND, V_{CC}=0\sim 3.6V$			$\pm 5$	$\mu A$
Quiescent Supply Current	$I_{CC}$	$V_{IN}=V_{CC}\ \text{or}\ GND, I_{OUT}=0$			10	$\mu A$
Additional quiescent Supply Current	$\Delta I_{CC}$	One input at $V_{CC}-0.6V$ ; other inputs at $V_{CC}$ or GND			500	$\mu A$
Input Capacitance (Note)	$C_{IN}$	$V_{IN}=V_{CC}\ \text{or}\ GND, V_{CC}=3.3V$		5		pF

Note: All typical values are at  $V_{CC} = 3.3\ V$

■ SWITCHING CHARACTERISTICS (Unless otherwise specified)

PARAMETER	SYMBOL	TEST CONDITIONS	MIN	TYP	MAX	UNIT
Propagation delay from input (A or B) to output (Y)	$t_{PLH}/t_{PHL}$	$V_{CC}=1.8V, C_L=30pF, R_L=1K\Omega$		13.4		ns
		$V_{CC}=2.5\pm 0.2V, C_L=30pF, R_L=500\Omega$	1		7.4	
		$V_{CC}=2.7V, C_L=50pF, R_L=500\Omega$			5.4	
		$V_{CC}=3.3\pm 0.3V, C_L=50pF, R_L=500\Omega$	1		4.4	
Skew between any two outputs of the same package switching in the same direction	$t_{sk(o)}$	$V_{CC}=3.3\pm 0.3V, C_L=50pF, R_L=500\Omega$			1	ns

■ OPERATING CHARACTERISTICS (Unless otherwise specified)

PARAMETER	SYMBOL	TEST CONDITIONS	MIN	TYP	MAX	UNIT
Power dissipation capacitance per gate	$C_{PD}$	$f=10MHz$	$V_{CC}=1.8V$		7.5	pF
			$V_{CC}=2.5V$		8.5	
			$V_{CC}=3.3V$		9.5	

■ TEST CIRCUIT AND WAVEFORMS

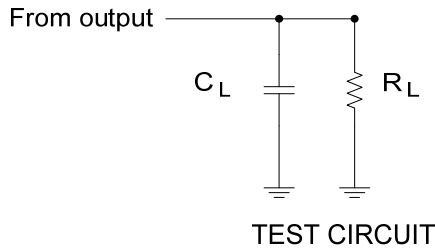

$V_{CC}$	Inputs		$V_M$	$C_L$	$R_L$
	$V_{IN}$	$t_r, t_f$			
$1.8V \pm 0.15V$	$V_{CC}$	$\leq 2ns$	$V_{CC}/2$	30pF	1K $\Omega$
$2.5V \pm 0.2V$	$V_{CC}$	$\leq 2ns$	$V_{CC}/2$	30pF	500 $\Omega$
2.7V	$V_{CC}$	$\leq 2.5ns$	1.5V	50pF	500 $\Omega$
$3.3V \pm 0.3V$	$V_{CC}$	$\leq 2.5ns$	1.5V	50pF	500 $\Omega$

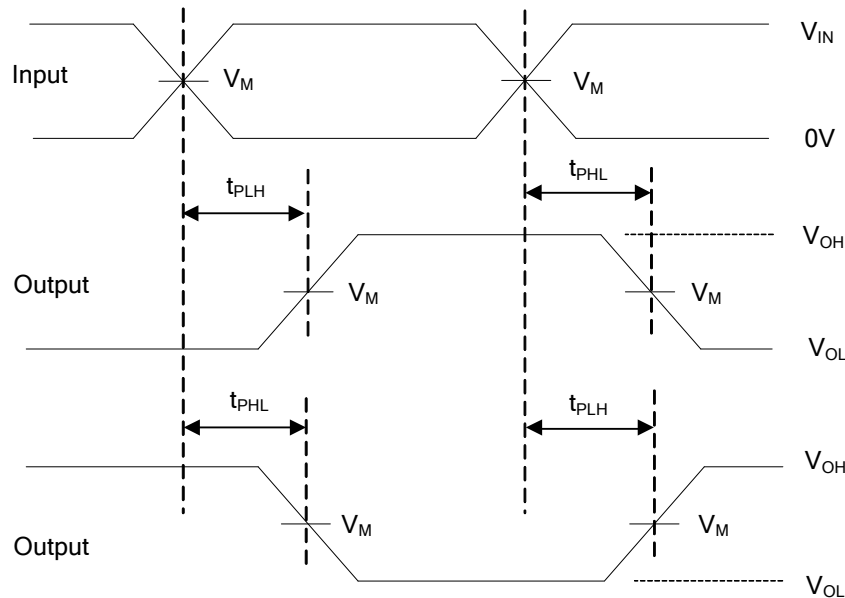

Propagation delay times  
 Inverting and noninverting outputs

- Notes: 1.  $C_L$  includes probe and jig capacitance.  
 2. All input pulses are supplied by generators having the following characteristics: PRR  $\leq 10MHz$ ,  $Z_o = 50\Omega$ .

UTC assumes no responsibility for equipment failures that result from using products at values that exceed, even momentarily, rated values (such as maximum ratings, operating condition ranges, or other parameters) listed in products specifications of any and all UTC products described or contained herein. UTC products are not designed for use in life support appliances, devices or systems where malfunction of these products can be reasonably expected to result in personal injury. Reproduction in whole or in part is prohibited without the prior written consent of the copyright owner. UTC reserves the right to make changes to information published in this document, including without limitation specifications and product descriptions, at any time and without notice. This document supersedes and replaces all information supplied prior to the publication hereof.