



## M293010

## LINEAR INTEGRATED CIRCUIT

### 1A, LOW-DROPOUT, 1.0~16V REGULATOR

#### DESCRIPTION

The UTC **M293010** is 1A low dropout liner voltage regulators that provide low voltage and high-current output. Designed especially for the high-current requirements in industrial and consumer applications; embedded core, memory, or logic supplies; TVs, VCRs, and office equipment.

The UTC **M293010** is an efficient voltage regulator with very low dropout voltage and very low ground current. This device delivers a regulated output at up to 1A. Included overcurrent and thermal protection improve overall system reliability. Devices with fixed output voltages are also available.

A inside bandgap reference provides accuracy and excellent temperature characteristics for regulator. IQ does not increase significantly as the dropout voltage is approached, an ideal feature in standby/resume power systems where data integrity is crucial. A inside power pnp provides a dropout voltage of less than 600mV at 1A of current. An LS-TTL/CMOS-compatible input gives the designer complete control over power up, standby, or power down. Low output voltages eliminate the need for expensive PWM buck converters. The low dropout voltage permits more efficient regulation before output regulation is lost.

The UTC **M293010** provided a 5-lead TO-252 style surface-mount plastic package with ground tab to provide a low-resistance path for maximum heat dissipation.

#### FEATURES

- \* 1A output current
- \* Dropout voltage 0.6V at  $I_{OUT}=1A$
- \*  $1\mu A$  maximum standby current
- \* Fast response
- \* Accurate current limiting
- \* Remote voltage sensing
- \* Thermal protection
- \* Over voltage protection
- \* Ground tab for superior heat dissipation

#### ORDERING INFORMATION

Ordering Number		Package	Packing
Lead Free	Halogen Free		
M293010L-xx-TN5-T	M293010G-xx-TN5-T	TO-252-5	Tube
M293010L-xx-TN5-R	M293010G-xx-TN5-R	TO-252-5	Tape Reel

Note: xx: Output Voltage, refer to Marking Information.

<p>M293010G-xx-TN5-T</p> <p>(1)Packing Type (2)Package Type (3)Output Voltage Code (4)Green Package</p>	<p>(1) T: Tube, R: Tape Reel (2) TN5: TO-252-5 (3) xx: Refer to Marking Information (4) G: Halogen Free and Lead Free, L: Lead Free</p>
---------------------------------------------------------------------------------------------------------------------	-----------------------------------------------------------------------------------------------------------------------------------------------------

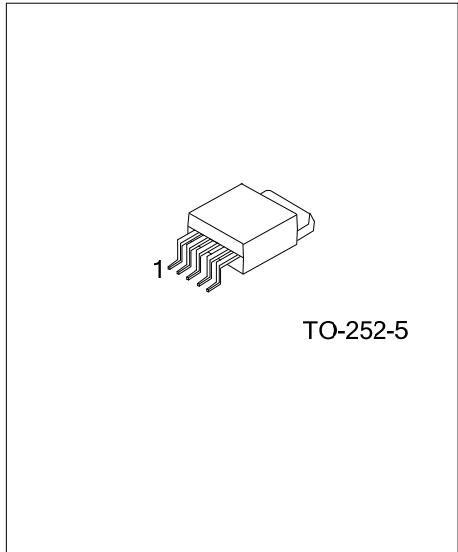

# M293010

## LINEAR INTEGRATED CIRCUIT

### MARKING INFORMATION

PACKAGE	VOLTAGE CODE	MARKING
TO-252-5	AD: ADJ	<div style="display: flex; align-items: center;"> <div style="border: 1px solid black; padding: 5px; margin-right: 10px;">                     UTC                      M293010                      XX□□□□□□                 </div> <div style="margin-left: 10px;">                     L: Lead Free                      G: Halogen Free                      Lot Code                      Date Code                 </div> </div> <p>Voltage Code ←</p>

### PIN CONFIGURATION

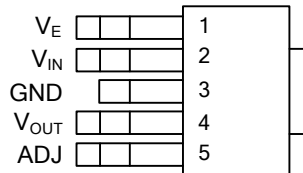

### PIN DESCRIPTION

PIN NO.	PIN NAME	DESCRIPTION
1	$V_E$	Enable
2	$V_{IN}$	Input
3	GND	Ground
4	$V_{OUT}$	Output
5	ADJ	Adjustable

### BLOCK DIAGRAM

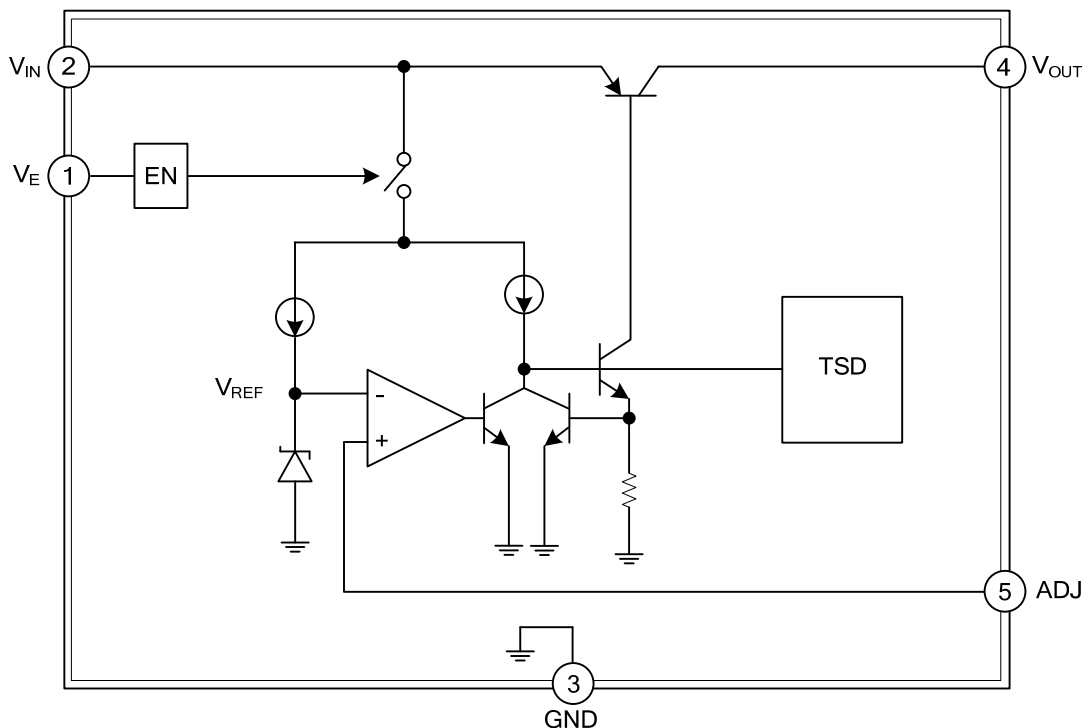

### ■ ABSOLUTE MAXIMUM RATING

PARAMETER	SYMBOL	RATINGS	UNIT
Input Voltage	$V_{IN}$	35	V
Output Current (Note 2)	$I_{OUT}$	1	A
Enable Input Voltage	$V_E$	35	V
Operating Junction Temperature	$T_J$	-40 ~ +125	°C
Storage Temperature	$T_{STG}$	-40 ~ +125	°C

Notes: 1. Absolute maximum ratings are those values beyond which the device could be permanently damaged. Absolute maximum ratings are stress ratings only and functional device operation is not implied.

2. Output current rating is limited by input voltage, duty cycle, and ambient temperature. Under any set of conditions, do not exceed a junction temperature of +125°C.

### ■ RECOMMENDED OPERATING CONDITIONS

PARAMETER	SYMBOL	RATINGS	UNIT
Input Voltage	$V_{IN}$	2.4 ~ 27	V
Output Current	$I_{OUT}$	0 ~ 1	A
Adjustable Voltage Range		1.2 ~ 16	V

### ■ ELECTRICAL CHARACTERISTICS

( $T_A=+25^\circ\text{C}$ ,  $V_{IN}=7\text{V}$ ,  $V_{OUT}=5\text{V}$  adjusted,  $V_E=2\text{V}$ , unless otherwise noted)

PARAMETER	SYMBOL	TEST CONDITIONS	MIN	TYP	MAX	UNIT
Output Voltage	$V_{OUT}$	$V_{IN}=V_{O(nom)}+1\text{V}$ , $I_{OUT}=10\text{mA}$		$V_{OUT(nom)}$		V
	$V_{OUT(off)}$	$V_E=0\text{V}$			0.5	V
Temperature Coefficient of Output Voltage	$a_{V_{OUT}}$	$0^\circ\text{C}\leq T_J\leq 100^\circ\text{C}$		$\pm 0.5$		mV/°C
Reference Voltage	$V_{REF}$	$I_{OUT}=10\text{mA}$	0.98	1.00	1.02	V
Short Circuit Current	$I_{OM}$	(Note 1)	1.1			A
Overvoltage Protection	$V_{IM}$	$I_{OUT}=10\text{mA}$	33			V
Line Regulation	$\Delta V_{OUT(\Delta V_I)}$	$V_{IN}=6.0\text{V}\sim 15\text{V}$ , $I_{OUT}=10\text{mA}$			30	mV
Load Regulation	$\Delta V_{OUT(\Delta I_O)}$	$I_{OUT}=0\text{A}\sim 1.0\text{A}$			75	mV
Dropout Voltage	$V_{INMIN}-V_{OUT}$	$I_{OUT}=0.5\text{A}$			0.3	V
		$I_{OUT}=1.0\text{A}$			0.6	V
Ground Current	$I_{GND}$	$I_{OUT}=0\text{mA}$ , $V_E=2.0\text{V}$		1.2		mA
		$V_E=0\text{V}$		0.1		mA
Control Input Voltage	$V_{EH}$	Output ON	2.0			V
	$V_{EL}$	Output OFF			0.8	V
Control Input Current	$I_{EH}$	$V_E=2.0\text{V}$			40	$\mu\text{A}$
	$I_{EL}$	$V_E=0\text{V}$		0	-5.0	$\mu\text{A}$
Ripple Rejection Ratio	PSRR	$100\text{Hz}\leq f\leq 120\text{Hz}$ , $I_{OUT}=100\text{mA}$		75		dB
Over Temperature	$T_J$	$I_{OUT}=10\text{mA}$		150		°C

Note: 1. Output short-circuit current is at point where output voltage has decreased 5% below  $V_{OUT(nom)}$ .

### ■ APPLICATIONS INFORMATION

#### Input Capacitor (C<sub>I</sub>, ≥ 22μF).

This is necessary either when the input line includes inductance or when the wiring is long.

#### Output Capacitor (C<sub>O</sub>, ≥ 47μF).

This device is not designed for a use with a very low ESR output capacitor such as a ceramic capacitor. Output oscillation may occur with that kind of capacitor. The recommended ESR is 0.2~2Ω at T<sub>A</sub>=25°C.

#### Output Voltage Adjustable Resistors (R1 and R2).

The output voltage is adjusted by R1 and R2. 10 kΩ for R2 is recommended.

$$R1=R2 \left( \frac{V_{OUT}}{V_{ADJ}} - 1 \right)$$

### ■ TYPICAL APPLICATION CIRCUIT

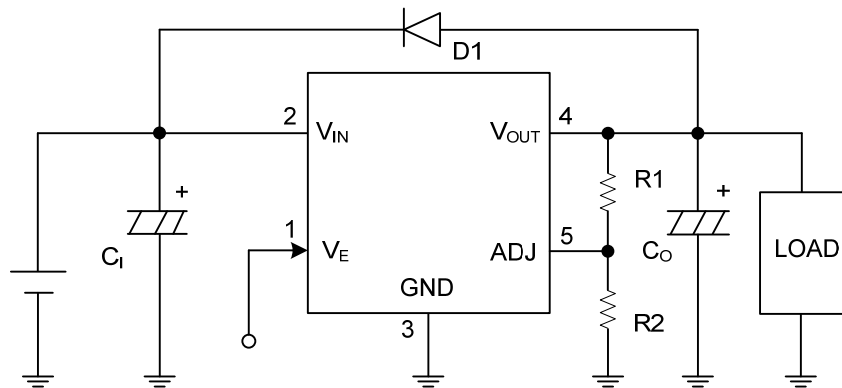

UTC assumes no responsibility for equipment failures that result from using products at values that exceed, even momentarily, rated values (such as maximum ratings, operating condition ranges, or other parameters) listed in products specifications of any and all UTC products described or contained herein. UTC products are not designed for use in life support appliances, devices or systems where malfunction of these products can be reasonably expected to result in personal injury. Reproduction in whole or in part is prohibited without the prior written consent of the copyright owner. UTC reserves the right to make changes to information published in this document, including without limitation specifications and product descriptions, at any time and without notice. This document supersedes and replaces all information supplied prior to the publication hereof.