



UTRS485

CMOS IC

FAIL-SAFE, 4.5MBPS, RS-485 / RS-422 TRANSCEIVERS WITH $\pm 12KV$ ESD-PROTECTED

DESCRIPTION

The UTC **UTRS485** is a half-duplex transceiver designed for RS-485 data bus network, which contains one transmitter and one receiver. The UTC **UTRS485** features a fail-safe receiver, which guarantees the receiver to output high when the receiver inputs are open.

The UTC **UTRS485** also features a hot-swap glitch free protection circuits which guarantee outputs of both the transmitter and the receiver in a high impedance state during the power up period. So that the large short current from power to ground will be disabled by glitch free function, which will save the power and enhance the efficiency of the power up.

The UTC **UTRS485** is optimized for signal rates up to 4.5Mbps with differential voltage of 2.3V. The UTC **UTRS485** also has the thermal shutdown function when the temperature is over 150°C and the protection of the current limitation in the transmitter to protect the itself from the damage by the system-fault conditions during normal operation.

FEATURES

- * Meet the requirements of the EIA/TIA-485 standards.
- * 5.0V single power supply.
- * True fail-safe receiver while maintaining EIA/TIA-485 compatibility.
- * Hot-Swap glitch free protection on control inputs.
- * Up to 32 transceivers on the bus.
- * Driver short circuit current limit.
- * Thermal shutdown for overload protection.

ORDERING INFORMATION

Ordering Number		Package	Packing
Lead Free	Halogen Free		
UTRS485L-D08-T	UTRS485G-D08-T	DIP-8	Tube
UTRS485L-S08-R	UTRS485G-S08-R	SOP-8	Tape Reel

<p>UTRS485G-D08-T</p>	<p>(1) T: Tube, R: Tape Reel (2) D08: DIP-8, S08: SOP-8 (3) G: Halogen Free and Lead Free, L: Lead Free</p>
-----------------------	---

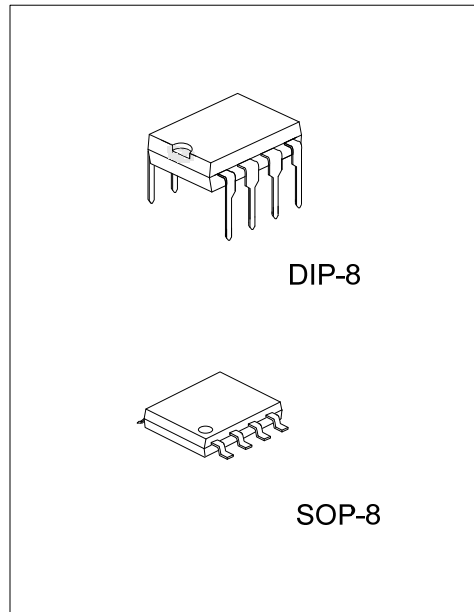

■ MARKING

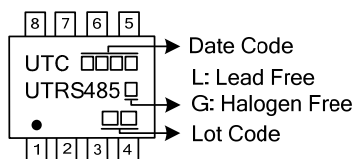

■ PIN CONFIGURATION

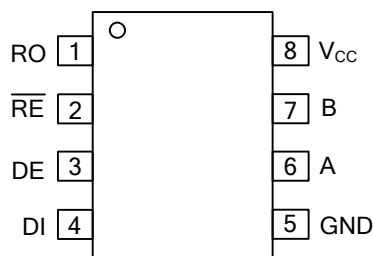

■ PIN DESCRIPTION

PIN NO.	PIN NAME	DESCRIPTION
1	RO	Receiver output: if $A > B$ by 200mV, RO will be high; if $A < B$ by 200mV, RO will be low.
2	\overline{RE}	Receiver output enable. RO is enable when \overline{RE} is low; RO is high impedance when \overline{RE} is high.
3	DE	Driver output enable. The driver outputs, Y and Z, are enabled by bringing DE high. They are high impedance when DE is low. If the driver outputs are enabled, the parts function as line drivers. While they are high impedance, they function as line receivers if \overline{RE} is low.
4	DI	Driver Input. A low on DI forces output Y low and output Z high. Similarly, a high on DI forces output Y high and output Z low.
5	GND	Ground
6	A	Non-inverting receiver input and non-inverting driver output
7	B	Inverting receiver input and inverting driver output
8	V_{CC}	Positive supply; $4.75V \leq V_{CC} \leq 5.25V$

■ BLOCK DIAGRAM

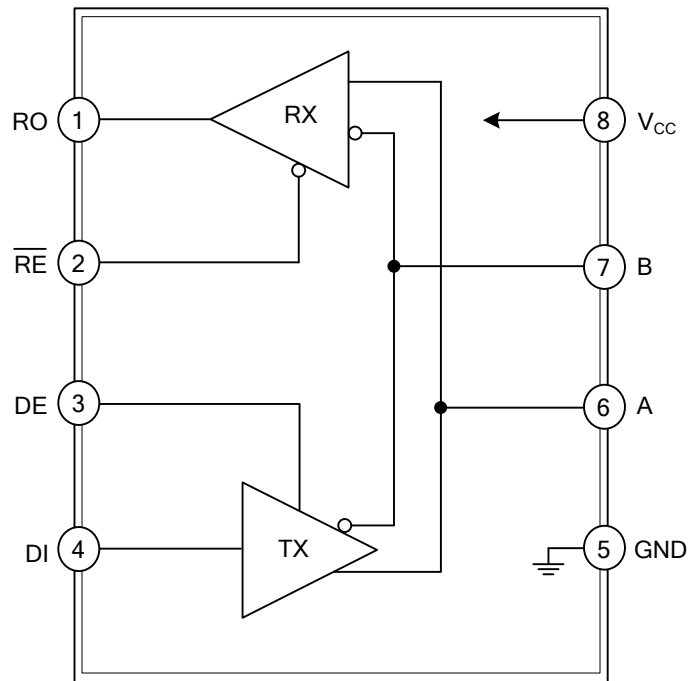

■ ABSOLUTE MAXIMUM RATING

PARAMETER	SYMBOL	RATINGS	UNIT
Supply Voltage	V_{CC}	7.0	V
Control Input Voltage (\overline{RE} , DE)		V_{CC}	V
Driver Input Voltage (DI)	DI	V_{CC}	V
Driver Output Voltage (A, B)		± 12.5	V
Receiver Input Voltage (A, B)		± 12.5	V
Receiver Output Voltage (RO)		V_{CC}	V
Continuous Power Dissipation ($T_A=+70^\circ\text{C}$)	DIP-8	800	mW
	SOP-8	625	mW
Operating Temperature Ranges	T_{OPR}	-40 ~ +85	$^\circ\text{C}$
Storage Temperature Range	T_{STG}	-65 ~ +160	$^\circ\text{C}$

Note: Absolute maximum ratings are those values beyond which the device could be permanently damaged. Absolute maximum ratings are stress ratings only and functional device operation is not implied.

■ DC ELECTRICAL CHARACTERISTICS

($V_{CC}=5.0\text{V} \pm 5\%$, $T_A=T_{MIN}$ to T_{MAX} , unless otherwise noted. (Note 1, 2))

PARAMETER	SYMBOL	TEST CONDITIONS	MIN	TYP	MAX	UNIT
Differential Driver Output (No Load)	V_{OD1}				5.0	V
Differential Driver Output (with Load)	V_{OD2}	R=50 Ω (RS-422)	2.0			V
		Fig.1, R=27 Ω (RS-485)	1.5		5.0	V
Change in Magnitude of Driver Differential Output Voltage for Complementary Output States	ΔV_{OD}	Fig.1, R=27 Ω or 50 Ω			0.2	V
Driver Common-Mode Output Voltage	V_{OC}	Fig.1, R=27 Ω or 50 Ω			3.0	V
Change in Magnitude of Driver Common-Mode Output Voltage for Complementary Output States	ΔV_{OC}	Fig.1, R=27 Ω or 50 Ω			0.2	V
Input High Voltage	V_{IH1}	DE, DI, \overline{RE}	2.0			V
Input Low Voltage	V_{IL1}	DE, DI, \overline{RE}			0.8	V
Input Current	I_{IN1}	DE, DI, \overline{RE}			± 2.0	μA
Input Current (A, B)	I_{IN2}	DE=0V; $V_{CC}=0\text{V}$ or 5.25V	$V_{IN}=12\text{V}$		1.0	mA
			$V_{IN}=-7\text{V}$		-0.8	mA
Receiver Differential Threshold Voltage	V_{TH}	$V_{CM}=+2.5\text{V}$	-0.2		0.2	V
Receiver Input Hysteresis	ΔV_{TH}	$V_{CM}=0\text{V}$		70		mV
Receiver Output High Voltage	V_{OH}	$I_O=-4\text{mA}$, $V_{ID}=200\text{mV}$	3.5			V
Receiver Output Low Voltage	V_{OL}	$I_O=4\text{mA}$, $V_{ID}=-200\text{mV}$			0.5	V
Three-State (High Impedance) Output Current at Receiver	I_{OZR}	$0.4\text{V} \leq V_O \leq 2.4\text{V}$			± 1.0	μA
Receiver Input Resistance	R_{IN}	$-7\text{V} \leq V_{CM} \leq +12\text{V}$	12			k Ω
No-Load Supply Current (Note 3)	I_{CC}	$\overline{RE}=0\text{V}$ or V_{CC}	DE= V_{CC}	500	900	μA
			DE=0V	300	500	μA
Driver Short-Circuit Current, V_O =High	I_{OSD1}	$-7\text{V} \leq V_O \leq 12\text{V}$ (Note 4)	35		250	mA
Driver Short-Circuit Current, V_O =Low	I_{OSD2}	$-7\text{V} \leq V_O \leq 12\text{V}$ (Note 4)	35		250	mA
Receiver Short-Circuit Current	I_{OSR}	$0\text{V} \leq V_O \leq V_{CC}$	± 7		± 95	mA

■ SWITCHING CHARACTERISTICS

($V_{CC}=+5.0V \pm 5\%$, $T_A=T_{MIN}$ to T_{MAX} , unless otherwise noted.) (Note 1, 2)

PARAMETER	SYMBOL	TEST CONDITIONS	MIN	TYP	MAX	UNIT
Driver Input to Output	t_{DPLH}	Fig.3 and 5, $R_{DIFF}=54\Omega$, $C_{L1}=C_{L2}=100pF$		50	200	ns
	t_{DPHL}			50	200	ns
Driver Output Skew to Output	t_{DSKEW}	Fig.3 and 5, $R_{DIFF}=54\Omega$, $C_{L1}=C_{L2}=100pF$		10		ns
Driver Rise or Fall Time	t_{DR} , t_{DF}	Fig.3 and 5, $R_{DIFF}=54\Omega$, $C_{L1}=C_{L2}=100pF$		15	150	ns
Driver Enable to Output High	t_{DZH}	Fig.4 and 6, $C_L=100pF$, S2 Closed		80	200	ns
Driver Enable to Output Low	t_{DZL}	Fig.4 and 6, $C_L=100pF$, S1 Closed		80	200	ns
Driver Disable Time from Low	t_{DLZ}	Fig.4 and 6, $C_L=15pF$, S1 Closed		80	200	ns
Driver Disable Time from High	t_{DHZ}	Fig.4 and 6, $C_L=15pF$, S2 Closed		80	200	ns
Receiver Input to Output	t_{RPLH} , t_{RPHL}	Fig.3 and 7, $R_{DIFF}=54\Omega$, $C_{L1}=C_{L2}=100pF$		500		ns
$ t_{PLH} - t_{PHL} $ Differential Receiver Skew	t_{RSKD}	Fig.3 and 7, $R_{DIFF}=54\Omega$, $C_{L1}=C_{L2}=100pF$		100		ns
Receiver Enable to Output Low	t_{RZL}	Fig.2 and 8, $C_{RL}=15pF$, S1 Closed		30	200	ns
Receiver Enable to Output High	t_{RZH}	Fig.2 and 8, $C_{RL}=15pF$, S2 Closed		30	200	ns
Receiver Disable Time from Low	t_{RLZ}	Fig.2 and 8, $C_{RL}=15pF$, S1 Closed		30	200	ns
Receiver Disable Time from High	t_{RHZ}	Fig.2 and 8, $C_{RL}=15pF$, S2 Closed		30	200	ns
Maximum Data Rate	f_{MAX}				4.5	Mbps

Notes: 1. All currents into the device are positive; all currents out of the device are negative. All voltages are referenced to device ground unless otherwise specified.

2. All typical specifications are given for $V_{CC}=5.0V$ and $T_A=+25^\circ C$

3. Supply current specification is valid for loaded transmitters when $DE=0V$

4. Applies to peak current

■ FUNCTION TABLE

Table 1 TRANSMITTING

INPUTS			OUTPUTS	
\overline{RE}	DE	DI	B	A
X	1	1	0	1
X	1	0	1	0
0	0	X	High-Z	High-Z
1	0	X	High-Z	High-Z

Table 2 RECEIVING

INPUTS			OUTPUTS
\overline{RE}	DE	A-B	RO
0	0	$\geq +0.2V$	1
0	0	$\leq -0.2V$	0
0	0	Inputs open	1
1	0	X	High-Z

X = Don't care
 High-Z = High impedance

TEST CIRCUIT

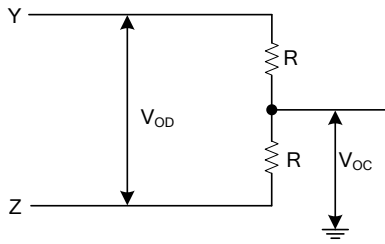

Fig. 1 Driver DC Test Load

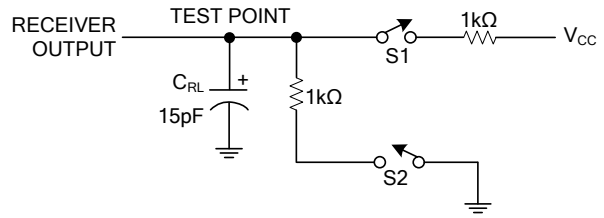

Fig. 2 Receiver Timing Test Load

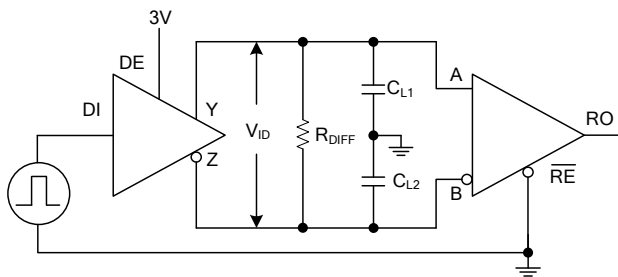

Fig. 3 Driver/Receiver Timing Test Circuit

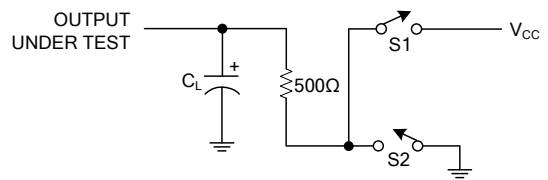

Fig. 4 Driver Timing Test Load

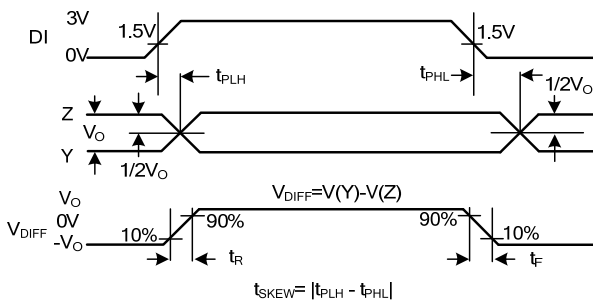

Fig. 5 Driver Propagation Delays

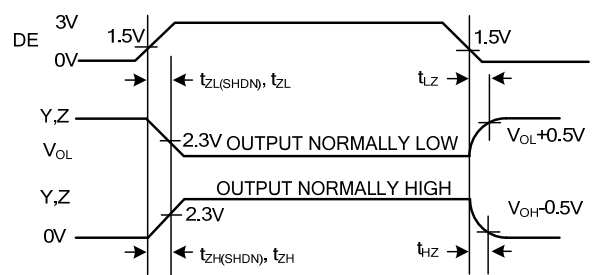

Fig. 6 Driver Enable and Disable Times

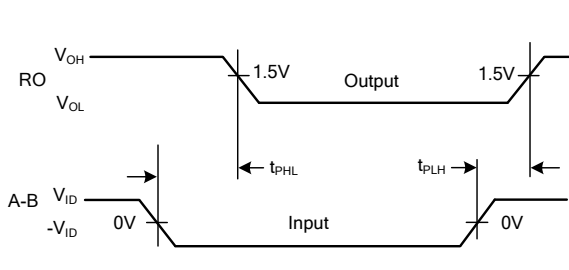

Fig. 7 Receiver Propagation Delays

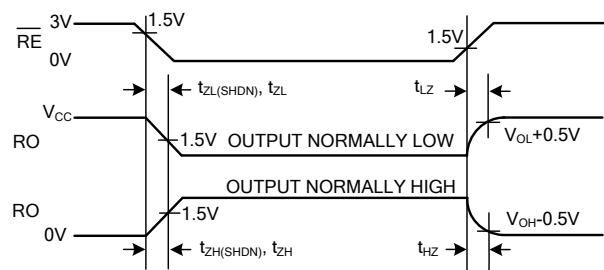
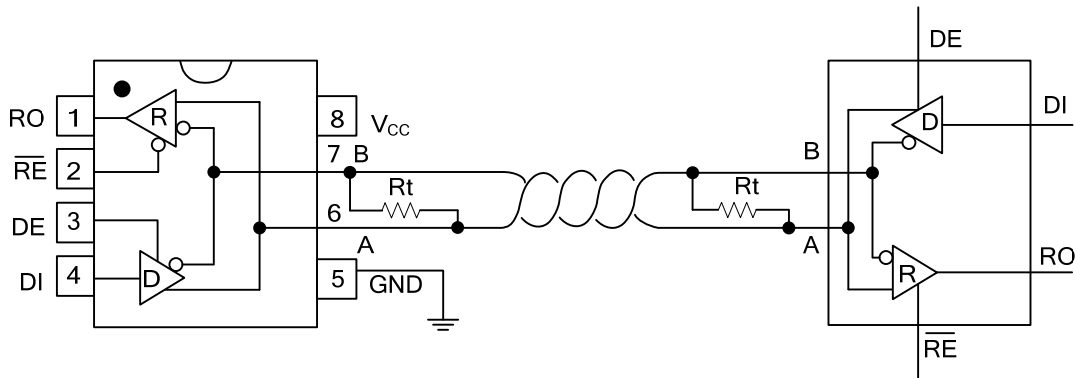

Fig. 8 Receiver Enable and Disable Times

■ TYPICAL APPLICATION CIRCUIT



Note: Pin labels Y and Z on timing, test, and waveform diagrams refer to pins A and B when DE is high.

UTC assumes no responsibility for equipment failures that result from using products at values that exceed, even momentarily, rated values (such as maximum ratings, operating condition ranges, or other parameters) listed in products specifications of any and all UTC products described or contained herein. UTC products are not designed for use in life support appliances, devices or systems where malfunction of these products can be reasonably expected to result in personal injury. Reproduction in whole or in part is prohibited without the prior written consent of the copyright owner. UTC reserves the right to make changes to information published in this document, including without limitation specifications and product descriptions, at any time and without notice. This document supersedes and replaces all information supplied prior to the publication hereof.