



POWER DISTRIBUTION SWITCH

DESCRIPTION

The UTC **US107** is a power distribution switch. It is intended for applications such as USB where heavy capacitive loads and short-circuits are likely to be encountered. This family offers multiple devices with fixed current-limit thresholds for applications between 1.2 A, 1.7A and 2.5 A.

The $R_{DS(ON)}$ of the MOSFET switch is as low as 70mΩ. \overline{OC} is open-drain output report over-current or over-temperature event which has typical 9ms deglitch timeout period, also reports output reverse-voltage condition with typical 5ms deglitch timeout period.

The UTC **US107** incorporates protection circuits including current limiting circuit with foldback function, thermal shutdown circuit designed to prevent catastrophic switch failure due to increasing power dissipation when continuous heavy loads or short circuit occurs. Besides, a built-in charge pump is used to drive the N-channel MOSFET that is free of parasitic body diode to eliminate any reversed current flow across the switch when it is powered off.

The UTC **US107** is applied in high-side power protection switch, USB power management, USB host and self-powered hubs, USB bus-powered hubs, hot plug-in power supplies, battery-charger circuits.

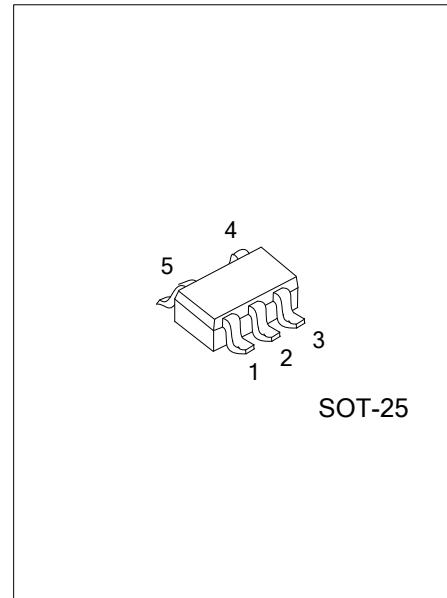

FEATURES

- * Single power switch family
- * Operating range: 3.0V~5.5V
- * 130μA quiescent supply current
- * 1μA maximum shutdown supply current
- * 70mΩ high-side MOSFET
- * 1mS typical rise time
- * Under voltage lockout
- * Logic level enable pin, available with Active-high or active-low version
- * No reverse current when power off
- * Output shutdown pull-low resistor
- * Deglitched open-drain over-current flag output (\overline{OC})
- * Output reverse-voltage protection

ORDERING INFORMATION

Ordering Number		Package	Pin Assignment					Packing
Lead Free	Halogen Free		1	2	3	4	5	
US107xxL-AF5-R	US107xxG-AF5-R	SOT-25	O	G	OC	C	I	Tape Reel

Note: Pin Assignment: O: OUT G: GND OC: \overline{OC} C: CE/ \overline{CE} I: IN

<p>US107xxG-AF5-R</p> <ul style="list-style-type: none"> (1)Packing Type (2)Package Type (3)Green Package (4)Active (5)I_{LIMIT} 	<ul style="list-style-type: none"> (1) R: Tape Reel (2) AF5: SOT-25 (3) G: Halogen Free and Lead Free, L: Lead Free (4) L: Low, H: High (5) A: 2.2A, B: 1.7A, C: 1.2A
--	--

MARKING

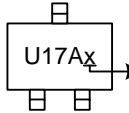
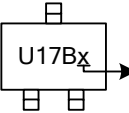
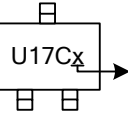
US107A	US107B	US107C
 <p>U17Ax → L: Low, H: High</p>	 <p>U17Bx → L: Low, H: High</p>	 <p>U17Cx → L: Low, H: High</p>

PIN CONFIGURATION

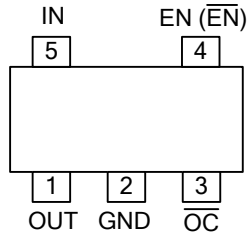

PIN DESCRIPTION

PIN NO.	PIN NAME	DESCRIPTION
1	OUT	Switch Output: Output MOSFET Source of switch. Typically connect to switched side of load.
2	GND	Ground
3	OC	Over-Current: Open-Drain \overline{OC} output.
4	EN(\overline{EN})	Enable: Logic level enable input. Make sure EN pin never floating.
5	IN	Input Supply: Output MOSFET Drain, which also supplies IC's internal circuitry. Connect to positive supply.

BLOCK DIAGRAM

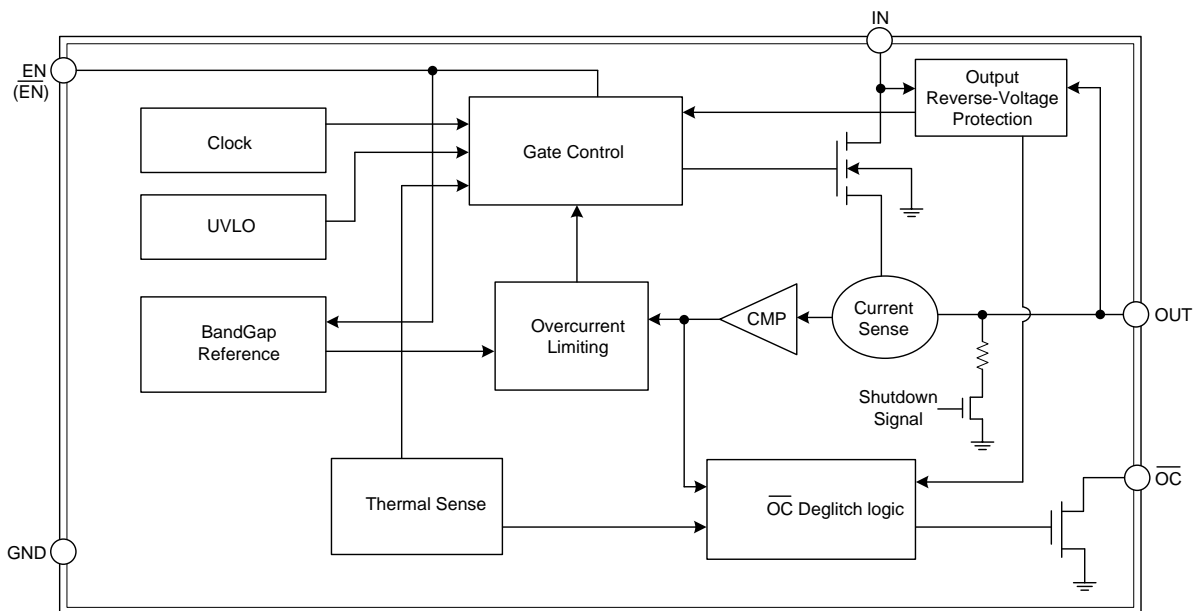

■ **ABSOLUTE MAXIMUM RATING** ($T_A=25^{\circ}\text{C}$, unless otherwise specified)

PARAMETER	SYMBOL	RATINGS	UNIT
Supply Voltage	V_{IN}	6	V
Output Voltage	V_{OUT}	6	V
Output Current	I_{OUT}	Internally Limited	
Enable Input	V_{EN}	-0.3 ~ 6	V
Continuous Power Dissipation (Note 2)	P_{D}	0.5	W
Junction Temperature	T_{J}	150	$^{\circ}\text{C}$
Storage Temperature	T_{STG}	-65 ~ +150	$^{\circ}\text{C}$

Notes: 1. Absolute maximum ratings are those values beyond which the device could be permanently damaged. Absolute maximum ratings are stress ratings only and functional device operation is not implied.
2. Please refer to Minimum Footprint PCB Layout Section.

■ **OPERATING RATINGS**

PARAMETER	SYMBOL	RATINGS	UNIT
Supply Voltage	V_{IN}	3.0 ~ 5.5	V
Operating Temperature	T_{A}	-40 ~ +85	$^{\circ}\text{C}$

■ **THERMAL DATA**

PARAMETER	SYMBOL	RATINGS	UNIT
Junction to Ambient (Note 2)	θ_{JA}	260	$^{\circ}\text{C}/\text{W}$
Junction to Case	θ_{JC}	85	$^{\circ}\text{C}/\text{W}$

■ ELECTRICAL CHARACTERISTICS ($V_{IN}=5V$, $C_{IN}=1\mu F$, $C_{OUT}=1\mu F$, $R_L=10\Omega$, $T_A=25^\circ C$)

The device is not guaranteed to function outside its operating conditions. Parameters with MIN and/or MAX limits are 100% tested at +25°C, unless otherwise specified.

PARAMETER	SYMBOL	TEST CONDITIONS	MIN	TYP	MAX	UNIT
Input Voltage Range	V_{IN}		3.0		5.5	V
Output MOS $R_{DS(ON)}$	$R_{DS(ON)}$			70	85	mΩ
Supply Current	I_{ON}			130	190	μA
Shutdown Supply Current	I_{OFF}			0.1	1	μA
Output Turn-on Rising Time	T_{ON}	$R_L=10\Omega$, 90% Settling	$V_{IN}=5V$	1.4	1.8	ms
			$V_{IN}=3.3V$	2	2.4	ms
Over Current Trigger Point	I_{LIMIT}	US107A	2.2	2.5	2.8	A
		US107B	1.7	2.0	2.3	A
		US107C	1.2	1.5	1.8	A
Fold-Back Current	$I_{SC(FB)}$	US107A, $V_{IN}>3.5V$ and $V_{OUT}<1V$		1.6		A
		US107B, $V_{IN}>3.5V$ and $V_{OUT}<1V$		1.3		A
		US107C, $V_{IN}>3.5V$ and $V_{OUT}<1V$		1.0		A
EN Input Threshold-High V_{IH}	V_{IH}		1.2			V
EN Input Threshold-Low V_{IL}	V_{IL}				0.6	V
Shutdown Pull Low Resistance	R_{PD}			300		Ω
Output Leakage Current	$I_{O(LEAK)}$	EN="0", $V_{OUT}=0V$		0.5	1	μA
V_{IN} Under Voltage Lockout	V_{UVLO}	V_{IN} Increasing	2.2	2.4	2.9	V
V_{IN} Under Voltage Hysteresis	ΔV_{UVLO}	V_{IN} Decreasing		200		mV
Thermal Limit	T_{SD}			140		°C
Thermal Limit Hysteresis	ΔT_{SD}			20		°C
\overline{OC} Deglitch	T_D	\overline{OC} Assertion or Deassertion	4	9	15	ms
\overline{OC} Output Low Voltage	V_{OC_OFF}	$I_{\overline{OC}}=2mA$			0.4	V
\overline{OC} Off-State Current	I_{OC_OFF}	$V_{\overline{OC}}=5V$			1	μA
Output Reverse-Voltage Trigger Point ($V_{OUT}-V_{IN}$)	V_{REV}	$V_{IN}=5V$	10	200	450	mV
Output Reverse-Current Trigger Point	I_{REV}		200	400	800	mA
Output Reverse-Voltage Deglitch Time	T_{DREV}	$V_{IN}=5V$	3	5	7	ms
t_{IOS} Response Time to Short Circuit	t_{IOS}	$V_{IN}=5V$, See Figure 1.2		1.5		μs

■ ELECTRICAL CHARACTERISTICS (Cont.)

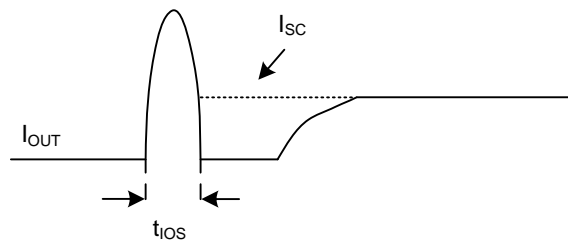

Figure 1

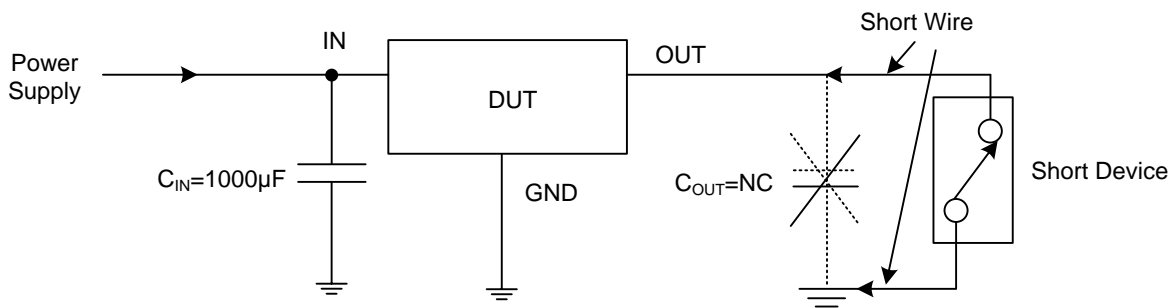

Figure 2

Note:

To exactly identify the short circuit characteristic of IC, avoid the test result interfered by parasitic inductor, output capacitor, and contact resistor. It is necessary to follow the recommendation as follows.

Please,

1. Add 1000 μ F of capacitor between V_{IN} and GND, and close to IC.
2. Remove output capacitor.
3. Shorter the short circuit device wire.
4. Measure output current (I_{OUT}).

■ FUNCTIONAL DESCRIPTION

Input and Output

IN (input) is the power supply connection to the logic circuitry and the drain of the output MOSFET. OUT (output) is the source of the output MOSFET. In a typical application, current flows through the switch from IN to OUT toward the load. Both OUT pins must be connected together to the load.

Thermal Shutdown

The thermal shutdown circuit is used to prevent damage occurs when the die temperature becomes higher than approximately 140°C. After 20°C of hysteresis, the switch will automatically restart if it enabled. When these devices are disabled or the fault is removed, the output and \overline{OC} signal will continue to cycle on and off.

Undervoltage Lockout

UVLO (Under-voltage Lockout) turns off the MOSFET switch once the input voltage falls below 2.2V, and the \overline{OC} is in active. If the input voltage exceeds approximately 2.4V, the switch will be turned on. Under-voltage detection functions only when the switch is enabled.

Over Current Trigger Point

The typical over current trigger point of UTC **US107** is 2.5A, 2A, 1.5A. There is foldback of current limit when $V_{IN}>3.5V$ and $V_{OUT}<1V$.

Output Reverse-Voltage Protection

The output reverse-voltage protection turns off the MOSFET switch whenever the output voltage is higher than the input voltage by 20mV (typ) for 5ms (typ) and the MOSFET switch will turn on when output reverse-voltage condition is removed for 5ms (typ).

\overline{OC} Function

The \overline{OC} open-drain output is asserted (active low) when an over current condition is encountered after a 9ms deglitch timeout. The output remains asserted until the overcurrent condition is removed. Over temperature condition is also reported immediately by \overline{OC} open-drain output. In addition, \overline{OC} is also asserted (active low) in output reverse-voltage condition with typical 5ms deglitch timeout period until the output reverse-voltage condition is removed.

■ TEST CIRCUIT

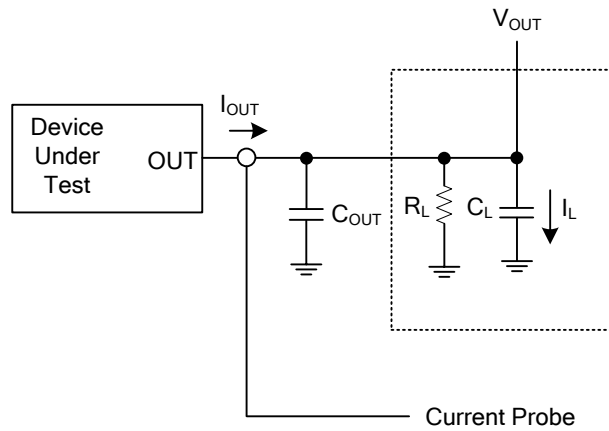

■ TIMING DIAGRAMS

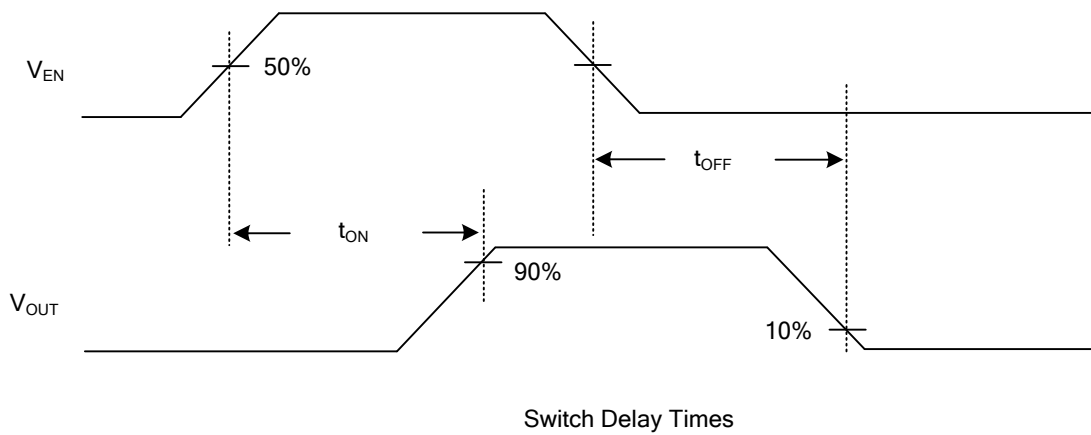
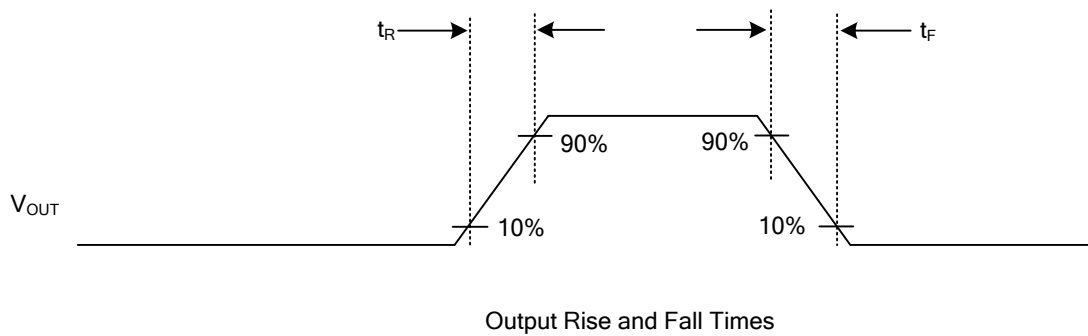

■ **TYPICAL APPLICATION CIRCUIT**

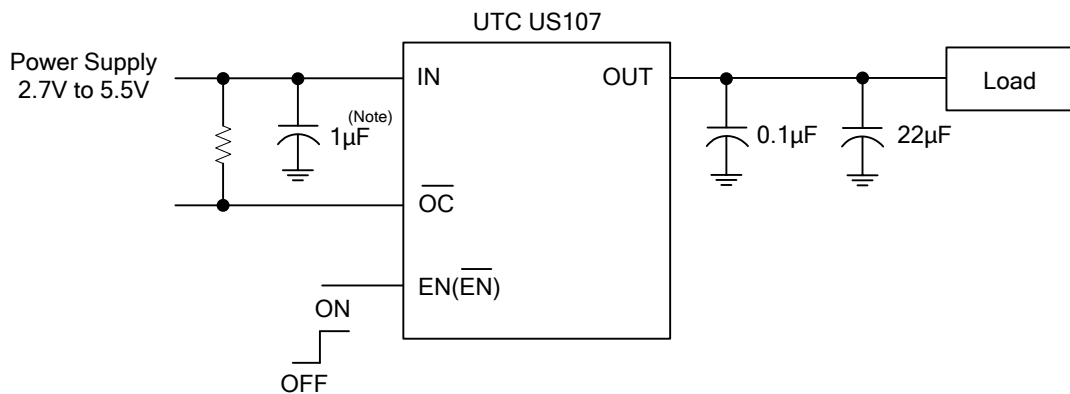

Note : 1µF of input capacitor is enough in most application cases.
 If the PCB trace of power rail to IN is long, larger input capacitor is necessary.

UTC assumes no responsibility for equipment failures that result from using products at values that exceed, even momentarily, rated values (such as maximum ratings, operating condition ranges, or other parameters) listed in products specifications of any and all UTC products described or contained herein. UTC products are not designed for use in life support appliances, devices or systems where malfunction of these products can be reasonably expected to result in personal injury. Reproduction in whole or in part is prohibited without the prior written consent of the copyright owner. UTC reserves the right to make changes to information published in this document, including without limitation specifications and product descriptions, at any time and without notice. This document supersedes and replaces all information supplied prior to the publication hereof.