



C_L CAPACITOR-LESS 500mA LOW POWER CONSUMPTION HIGH SPEED LDO REGULATOR

DESCRIPTION

The UTC LR9203 is a CMOS-based low dropout regulator with high output voltage accuracy, low dropout, high PSRR and low quiescent current. The devices can provide stable output voltages even without a load capacitor C_L.

The C_L capacitor-less is possible because phase compensation is carried out internally unlike other LDOs where it is done externally. Since the output capacitor and noise bypass capacitor are able to be reduced, so saving the board design space.

When a C_L capacitor is used, the IC can discharge the electric charge stored at the output capacitor through the internal switch while in standby state, and as a result the V_{OUT} quickly returns to the V_{SS} level.

FEATURES

- * Maximum Output Current: 500mA
- * Output Accuracy: ±2.0%
- * Output Voltage Range: 1.2V~5.0V (0.05V increments)
- * Protection Current: Current Limiter (630mA TYP.), Short-circuit Protection, Thermal Shutdown
- * Dropout Voltage: 190mV @ V_{OUT}=2.8V, I_{OUT}=300mA
- * Low Power Consumption: 15µA (TYP.), 0.5µA (in standby)
- * High PSRR: 55dB @ 1kHz, V_{OUT}=2.8V
- * Operating Ambient Temperature: -40°C~+85°C
- * C_L Capacitor-Less: Internal Phase Compensation

ORDERING INFORMATION

Ordering Number		Package	Packing
Lead Free	Halogen Free		
LR9203xL-xx-AE5-R	LR9203xG-xx-AE5-R	SOT-23-5	Tape Reel
LR9203xL-xx-AF5-R	LR9203xG-xx-AF5-R	SOT-25	Tape Reel

Note: xx: Output Voltage, refer to Marking Information.

<p>LR9203xG-xx-AE5-R</p>	<p>(1) R: Tape Reel (2) AE5: SOT-23-5, AF5: SOT-25 (3) xx: refer to Marking Information (4) G: Halogen Free and Lead Free, L: Lead Free (5) D: with auto discharge function / CE high active P: without auto discharge function / no CE pin</p>
--------------------------	--

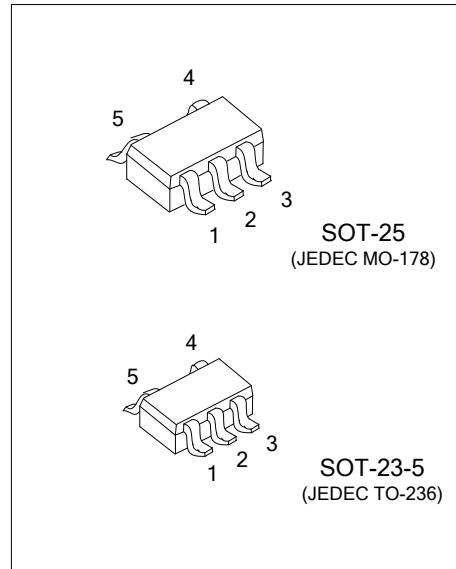

MARKING

PACKAGE	VOLTAGE CODE	MARKING
SOT-23-5 SOT-25	See Voltage Chart	

PIN CONFIGURATION

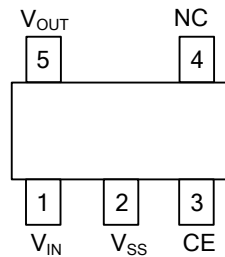

PIN DESCRIPTION

PIN NO.	PIN NAME	DESCRIPTION
1	V_{IN}	Input Pin
2	V_{SS}	Ground Pin
3	CE	Chip Enable Pin ("H" Enable, "L" or NC Disable)
4	NC	No Connection
5	V_{OUT}	Output Pin

BLOCK DIAGRAM

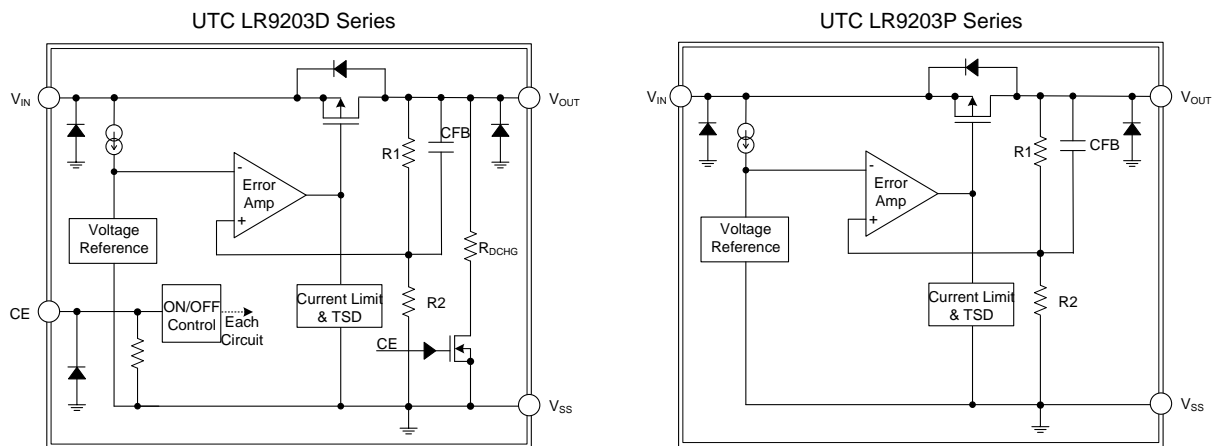

Note: Diodes inside the circuits are ESD protection diodes and parasitic diodes.

■ ABSOLUTE MAXIMUM RATING

PARAMETER	SYMBOL	RATINGS	UNIT
Input Voltage	V_{IN}	6.5	V
CE Input Voltage	V_{CE}	6.5	V
Power Dissipation	P_D	300	mW
Operating Ambient Temperature	T_{OPR}	40 ~ +85	°C
Storage Temperature	T_{STG}	-55 ~ +125	°C

Notes: 1. Absolute maximum ratings are those values beyond which the device could be permanently damaged. Absolute maximum ratings are stress ratings only and functional device operation is not implied.
2. The power dissipation measured with the test board condition is listed as reference data.

■ ELECTRICAL CHARACTERISTICS ($T_A=25^\circ\text{C}$, unless otherwise specified)

PARAMETER	SYMBOL	TEST CONDITIONS	CIRCUITS	MIN	TYP	MAX	UNIT
UTC LR9203D Type							
Output Voltage	$V_{OUT(E)}$ (Note 2)	$V_{CE}=V_{IN}$, $I_{OUT}=10\text{mA}$		$\times 0.98$ (Note 4)		$\times 1.02$ (Note 4)	V
Maximum Output Current	I_{OUTMAX}	$V_{CE}=V_{IN}$	1	500			mA
Load Regulation	ΔV_{OUT}	$V_{CE}=V_{IN}$, $0.1\text{mA} \leq I_{OUT} \leq 300\text{mA}$	1		20	50	mV
Dropout Voltage (Note 5)	V_D	$V_{CE}=V_{IN}$, $I_{OUT}=300\text{mA}$	1		E-1 (Note 8)		mV
Supply Current	I_{SS}	$V_{IN}=V_{CE}=6.0\text{V}$, $I_{OUT}=0\text{mA}$	2		15	30	μA
Stand-by Current	I_{STB}	$V_{IN}=6.0\text{V}$, $V_{CE}=V_{SS}$	2		0.01	0.5	μA
Line Regulation	$\frac{\Delta V_{OUT}}{(\Delta V_{IN} \cdot V_{OUT})}$	$V_{OUT(T)}+0.5\text{V} \leq V_{IN} \leq 6.0\text{V}$, $V_{CE}=V_{IN}$, $I_{OUT}=30\text{mA}$	1		E-2 (Note 9)		%/V
Input Voltage	V_{IN}		1			6.0	V
Output Voltage Temperature Characteristics	$\frac{\Delta V_{OUT}}{(\Delta T_{OPR} \cdot V_{OUT})}$	$V_{CE}=V_{IN}$, $I_{OUT}=30\text{mA}$, $-40^\circ\text{C} \leq T_{OPR} \leq 85^\circ\text{C}$	1		± 30		ppm/°C
Power Supply Rejection Ratio	PSRR	$V_{OUT(T)} \leq 4.75\text{V}$, $V_{IN}=\{V_{OUT(T)}+1.0\} V_{DC}+0.5\text{Vp-p}_{AC}$, $V_{CE}=V_{IN}$, $I_{OUT}=30\text{mA}$, $f=1\text{kHz}$ $V_{OUT(T)} \geq 4.80\text{V}$, $V_{IN}=5.75V_{DC}+0.5\text{Vp-p}_{AC}$, $V_{CE}=V_{IN}$, $I_{OUT}=30\text{mA}$, $f=1\text{kHz}$	3		55		dB
Current Limit	I_{LIM}	$V_{CE}=V_{IN}$	1	510	630	750	mA
Short-circuit Current	I_{SHORT}	$V_{CE}=V_{IN}$, Short V_{OUT} to V_{SS} level	1		120	210	mA
CE High Level Voltage	V_{CEH}		1	1.0		6.0	V
CE Low Level Voltage	V_{CEL}		1			0.3	V
CE High Level Current	I_{CEH}	$V_{IN}=V_{CE}=6.0\text{V}$	1	3.5	6	10	μA
CE Low Level Current	I_{CEL}	$V_{CE}=V_{SS}$	1	-0.1		0.1	μA
CL Discharge Resistance (Note 10)	R_{DCHG}	$V_{IN}=6.0\text{V}$, $V_{OUT}=5.0\text{V}$, $V_{CE}=V_{SS}$	1		600		Ω
Thermal Shutdown Detect Temperature	T_{TSD}	Junction Temperature			150		°C
Thermal Shutdown Hysteresis Width	T_{HYS}	$T_{TSD}-T_{TSR}$			25		°C

■ ELECTRICAL CHARACTERISTICS (Cont.)

PARAMETER	SYMBOL	TEST CONDITIONS	CIRCUITS	MIN	TYP	MAX	UNIT
UTC LR9203P Type							
Output Voltage	$V_{OUT(E)}$ (Note 2)	$I_{OUT}=10mA$		$\times 0.98$ (Note 4)		$\times 1.02$ (Note 4)	V
Maximum Output Current	I_{OUTMAX}		1	500			mA
Load Regulation	ΔV_{OUT}	$0.1mA \leq I_{OUT} \leq 300mA$	1		20	50	mV
Dropout Voltage (Note 5)	V_D	$I_{OUT}=300mA$	1		E-1 (Note 8)		mV
Supply Current	I_{SS}	$V_{IN}=6.0V, I_{OUT}=0mA$	2		15	30	μA
Line Regulation	$\frac{\Delta V_{OUT}}{(\Delta V_{IN} \cdot V_{OUT})}$	$V_{OUT(T)}+0.5V \leq V_{IN} \leq 6.0V,$ $I_{OUT}=30mA$	1		E-2 (Note 9)		%/V
Input Voltage	V_{IN}		1			6.0	V
Output Voltage Temperature Characteristics	$\frac{\Delta V_{OUT}}{(\Delta T_{OPR} \cdot V_{OUT})}$	$I_{OUT}=30mA, -40^{\circ}C \leq T_{OPR} \leq 85^{\circ}C$	1		± 30		ppm/ $^{\circ}C$
Power Supply Rejection Ratio	PSRR	$V_{OUT(T)} \leq 4.75V,$ $V_{IN}=\{V_{OUT(T)}+1.0\} V_{DC}+0.5V_{p-pAC},$ $I_{OUT}=30mA, f=1kHz$	3		55		dB
		$V_{OUT(T)} \geq 4.80V,$ $V_{IN}=5.75V_{DC}+0.5V_{p-pAC},$ $I_{OUT}=30mA, f=1kHz$					
Current Limit	I_{LIM}		1	510	630	750	mA
Short-circuit Current	I_{SHORT}	Short V_{OUT} to V_{SS} level	1		120	210	mA
Thermal Shutdown Detect Temperature	T_{TSD}	Junction Temperature			150		$^{\circ}C$
Thermal Shutdown Hysteresis Width	T_{HYS}	$T_{TSD}-T_{TSR}$			25		$^{\circ}C$

Notes: 1. Unless otherwise stated regarding input voltage conditions, $V_{IN}=V_{OUT(T)}(Note\ 3)+1.0V$.

2. $V_{OUT(E)}$: Effective output voltage (i.e. the output voltage when " $V_{OUT(T)}+1.0V$ " is provided at the V_{IN} pin while maintaining a certain I_{OUT} value.)

3. $V_{OUT(T)}$: Nominal output voltage.

4. Characteristics of the actual $V_{OUT(E)}$ by setting output voltage is shown in the voltage chart.

5. $V_D=V_{IN1}(Note\ 7)-V_{OUT1}(Note\ 6)$

6. V_{OUT1} is a voltage equal to 98% of the output voltage whenever an amply stabilized $I_{OUT}\{V_{OUT(T)}+1.0V\}$ is input.

7. V_{IN1} is an input voltage when V_{OUT1} appears at the V_{OUT} pin while the input voltage is gradually decreased.

8. E-1: DROPOUT VOLTAGE (Refer to Voltage Chart.)

9. E-2: LINE REGULATION (Refer to Voltage Chart.)

10. This function is built in the UTC **LR9203D** series only. The UTC **LR9203P** series discharges by only R1+R2 resistors as shown in the block diagrams.

■ VOLTAGE CHART

NOMINAL VOLTAGE (V)	CODE	E-0		E-1		E-2	
		OUTPUT VOLTAGE (V)		DROPOUT VOLTAGE (mV)		LINE REGULATION (%/V)	
		$V_{OUT(E)}$		V_D		$\Delta V_{OUT}/(\Delta V_{IN} \cdot V_{OUT})$	
$V_{OUT(T)}$		MIN.	MAX.	TYP.	MAX.	TYP.	MAX.
1.200	12	1.1800	1.2200	555	700	0.1	0.35
1.250	1C	1.2300	1.2700	↑	↑	↑	↑
1.300	13	1.2800	1.3200	↑	↑	↑	0.3
1.350	1D	1.3300	1.3700	↑	↑	↑	↑
1.400	14	1.3800	1.4200	440	600	↑	↑
1.450	1E	1.4300	1.4700	↑	↑	↑	↑
1.500	15	1.4800	1.5200	↑	↑	↑	↑
1.550	1F	1.5300	1.5700	↑	↑	↑	↑
1.600	16	1.5800	1.6200	360	450	↑	↑
1.650	1G	1.6300	1.6700	↑	↑	↑	↑
1.700	17	1.6800	1.7200	↑	↑	↑	↑
1.750	1H	1.7300	1.7700	↑	↑	↑	↑
1.800	18	1.7800	1.8200	300	390	↑	↑
1.850	1J	1.8300	1.8700	↑	↑	↑	↑
1.900	19	1.8800	1.9200	↑	↑	↑	↑
1.950	1K	1.9300	1.9700	↑	↑	↑	↑
2.000	20	1.9800	2.0200	265	330	↑	↑
2.050	2A	2.0295	2.0705	↑	↑	↑	↑
2.100	21	2.0790	2.1210	↑	↑	↑	↑
2.150	2B	2.1285	2.1715	↑	↑	↑	↑
2.200	22	2.1780	2.2220	240	310	↑	↑
2.250	2C	2.2275	2.2725	↑	↑	↑	↑
2.300	23	2.2770	2.3230	↑	↑	↑	↑
2.350	2D	2.3265	2.3735	↑	↑	↑	↑
2.400	24	2.3760	2.4240	↑	↑	↑	↑
2.450	2E	2.4255	2.4745	↑	↑	↑	↑
2.500	25	2.4750	2.5250	210	270	↑	↑
2.550	2F	2.5245	2.5755	↑	↑	↑	↑
2.600	26	2.5740	2.6260	↑	↑	↑	↑
2.650	2G	2.6235	2.6765	↑	↑	↑	↑
2.700	27	2.6730	2.7270	↑	↑	↑	↑
2.750	2H	2.7225	2.7775	↑	↑	↑	↑
2.800	28	2.7720	2.8280	190	250	↑	↑
2.850	2J	2.8215	2.8785	↑	↑	↑	↑
2.900	29	2.8710	2.9290	↑	↑	↑	↑
2.950	2K	2.9205	2.9795	↑	↑	↑	↑
3.000	30	2.9700	3.0300	↑	↑	↑	↑
3.050	3A	3.0195	3.0805	↑	↑	↑	↑
3.100	31	3.0690	3.1310	↑	↑	↑	↑
3.150	3B	3.1185	3.1815	190	250	0.1	0.3
3.200	32	3.1680	3.2320	170	230	↑	↑
3.250	3C	3.2175	3.2825	↑	↑	↑	↑
3.300	33	3.2670	3.3330	↑	↑	↑	↑
3.350	3D	3.3165	3.3835	↑	↑	↑	↑
3.400	34	3.3660	3.4340	↑	↑	↑	↑
3.450	3E	3.4155	3.4845	↑	↑	↑	↑

■ VOLTAGE CHART (Cont.)

NOMINAL VOLTAGE (V)	CODE	E-0		E-1		E-2	
		OUTPUT VOLTAGE (V)		DROPOUT VOLTAGE (mV)		LINE REGULATION (%/V)	
		$V_{OUT(E)}$		V_D		$\Delta V_{OUT}/(\Delta V_{IN} \cdot V_{OUT})$	
$V_{OUT(T)}$		MIN.	MAX.	TYP.	MAX.	TYP.	MAX.
3.500	35	3.4650	3.5350	↑	↑	↑	↑
3.550	3F	3.5145	3.5855	↑	↑	↑	↑
3.600	36	3.5640	3.6360	155	210	↑	↑
3.650	3G	3.6135	3.6865	↑	↑	↑	↑
3.700	37	3.6630	3.7370	↑	↑	↑	↑
3.750	3H	3.7125	3.7875	↑	↑	↑	↑
3.800	38	3.7620	3.8380	↑	↑	↑	↑
3.850	3J	3.8115	3.8885	↑	↑	↑	↑
3.900	39	3.8610	3.9390	↑	↑	↑	↑
3.950	3K	3.9105	3.9895	↑	↑	↑	↑
4.000	40	3.9600	4.0400	↑	↑	↑	↑
4.050	4A	4.0095	4.0905	↑	↑	↑	↑
4.100	41	4.0590	4.1410	↑	↑	↑	↑
4.150	4B	4.1085	4.1915	↑	↑	↑	↑
4.200	42	4.1580	4.2420	140	195	↑	↑
4.250	4C	4.2075	4.2925	↑	↑	↑	↑
4.300	43	4.2570	4.3430	↑	↑	↑	↑
4.350	4D	4.3065	4.3935	↑	↑	↑	↑
4.400	44	4.3560	4.4440	↑	↑	↑	↑
4.450	4E	4.4055	4.4945	↑	↑	↑	↑
4.500	45	4.4550	4.5450	↑	↑	↑	↑
4.550	4F	4.5045	4.5955	↑	↑	↑	↑
4.600	46	4.5540	4.6460	↑	↑	↑	↑
4.650	4G	4.6035	4.6965	↑	↑	↑	↑
4.700	47	4.6530	4.7470	↑	↑	↑	↑
4.750	4H	4.7025	4.7975	↑	↑	↑	↑
4.800	48	4.7520	4.8480	↑	↑	↑	↑
4.850	4J	4.8015	4.8985	↑	↑	↑	↑
4.900	49	4.8510	4.9490	↑	↑	↑	↑
4.950	4K	4.9005	4.9995	↑	↑	↑	↑
5.000	50	4.9500	5.0500	↑	↑	↑	↑

■ TEST CIRCUIT

Circuit 1

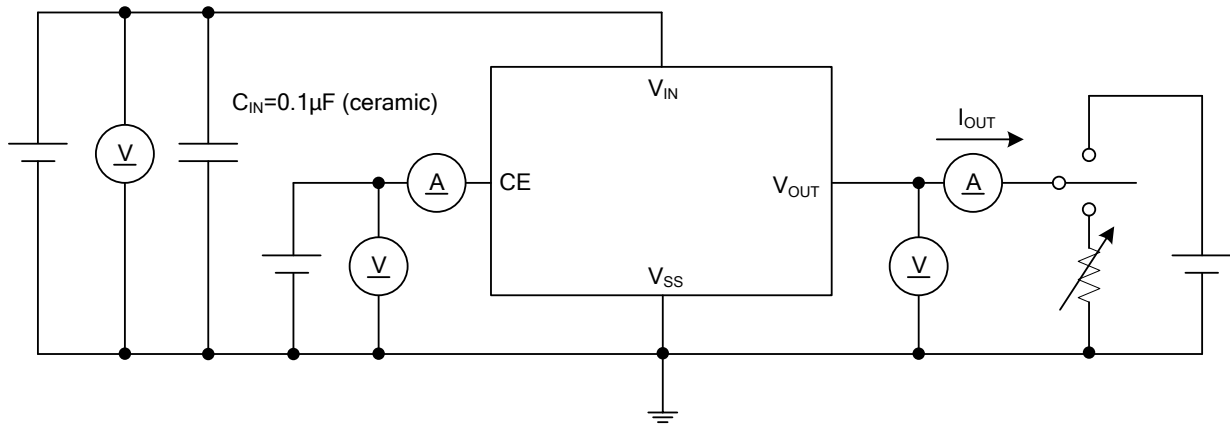

Circuit 2

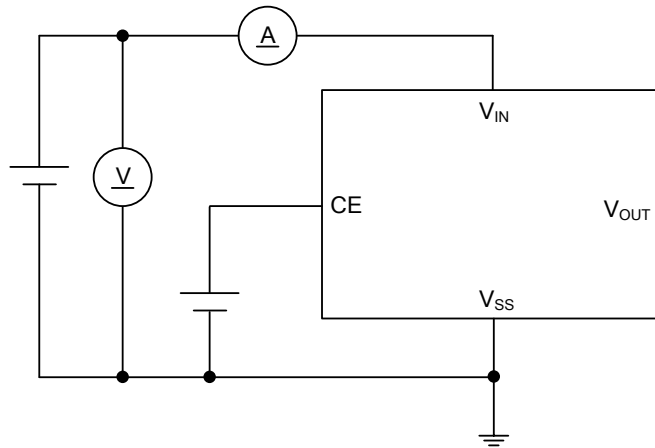

Circuit 3

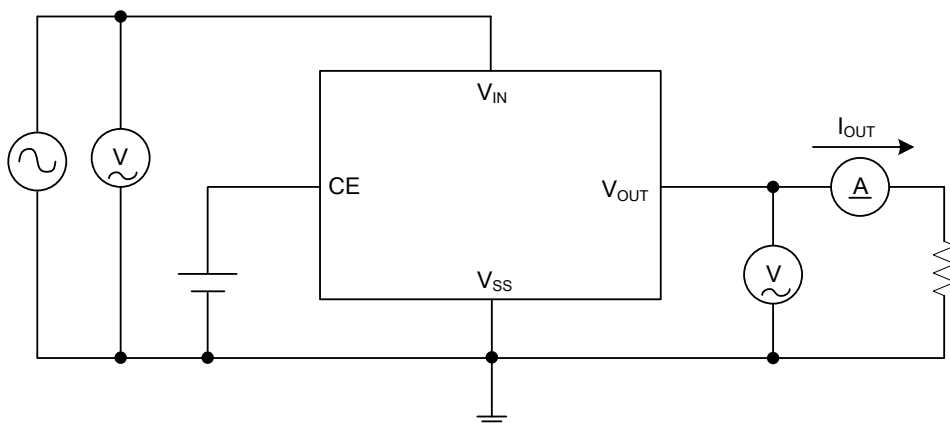

Note For the UTC LR9203P series, CE pin is connected to the V_{IN} internally.

■ TYPICAL APPLICATION CIRCUIT

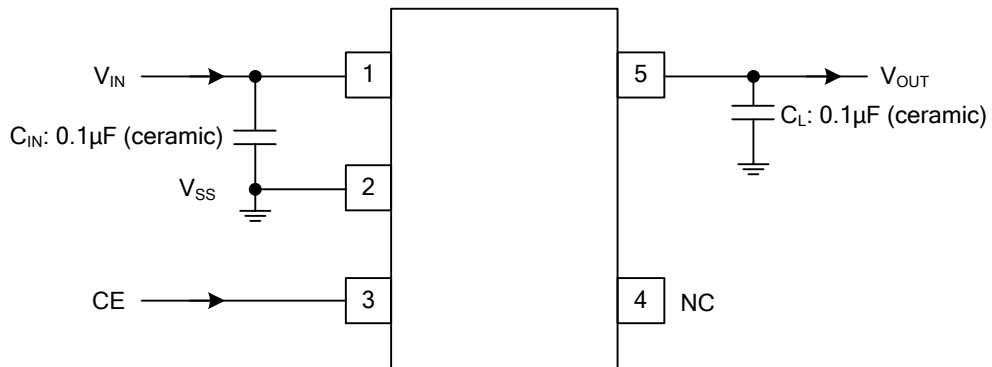

UTC assumes no responsibility for equipment failures that result from using products at values that exceed, even momentarily, rated values (such as maximum ratings, operating condition ranges, or other parameters) listed in products specifications of any and all UTC products described or contained herein. UTC products are not designed for use in life support appliances, devices or systems where malfunction of these products can be reasonably expected to result in personal injury. Reproduction in whole or in part is prohibited without the prior written consent of the copyright owner. UTC reserves the right to make changes to information published in this document, including without limitation specifications and product descriptions, at any time and without notice. This document supersedes and replaces all information supplied prior to the publication hereof.