



## UD05104

Preliminary

LINEAR INTEGRATED CIRCUIT

### 5V 1A 2.25MHz SYNCHRONOUS STEP-DOWN DC/DC CONVERTER

#### DESCRIPTION

The UTC **UD05104** is a 1A high frequency synchronous Step Down DC/DC converter using constant frequency, current mode architecture. The device integrates main switch and synchronous rectifier switch for high efficiency without an external schottky diode. To maximize light load efficiency, The UTC **UD05104** draws only 30µA quiescent current to improve light load efficiency. In shutdown, The UTC **UD05104** reduces supply current less than 1µA. The UTC **UD05104** can supply 1A of load current from 2.5V to 6.0V input voltage. The output voltage can be regulated as low as 0.6V. The switching frequency is internally set at 2.25MHz, as for operation mode: UTC **UD05104** is automatic PSM/PWM mode.

The UTC **UD05104** has built-in internal Soft Start, Short Circuit Protection and OTP functions, allowing the use of small surface mount inductors and capacitor.

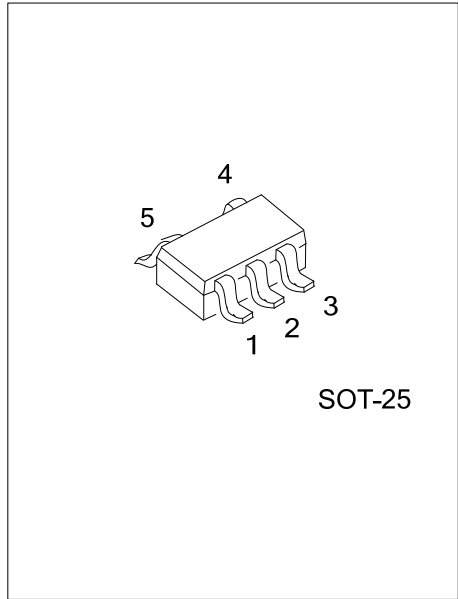

#### FEATURES

- \* Input Voltage Range from 2.5V to 6.0V
- \* +/-2% 0.6V Feedback Voltage Accuracy
- \* 2.25MHz Switching Frequency
- \* Continuous Output Current up to 1A
- \* Low Quiescent Current of 30µA
- \* 0.1µA Shutdown Current
- \* 100% Duty Cycle Operation
- \* Built-in 170mΩ/150mΩ Power Switch
- \* Internal Soft-Start
- \* Cycle-by-Cycle Current Limit Protection
- \* Over-Load and Hiccup Mode Short Circuit
- \* Thermal Shutdown Protection

#### ORDERING INFORMATION

Ordering Number		Package	Packing
Lead Free	Halogen Free		
UD05104G-AF5-R	UD05104G-AF5-R	SOT-25	Tape Reel

<p>UD05104G-AF5-R</p> <p>(1)Packing Type (2)Package Type (3)Green Package</p>	<p>(1) R: Tape Reel (2) AF5: SOT-25 (3) G: Halogen Free and Lead Free, L: Lead Free</p>
---	---

### MARKING

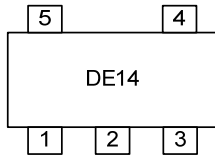

### PIN CONFIGURATION

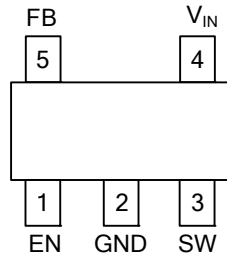

### PIN DESCRIPTION

PIN NO	PIN NAME	DESCRIPTION
1	EN	Regulator Enable Control Input, Don't float this PIN * Drive EN High Level to turn on the converter * Drive EN Low Level to turn off the converter
2	GND	Ground
3	SW	Power Switches Node
4	V <sub>IN</sub>	Main Input Supply Voltage
5	FB	Voltage Feedback

### BLOCK DIAGRAM

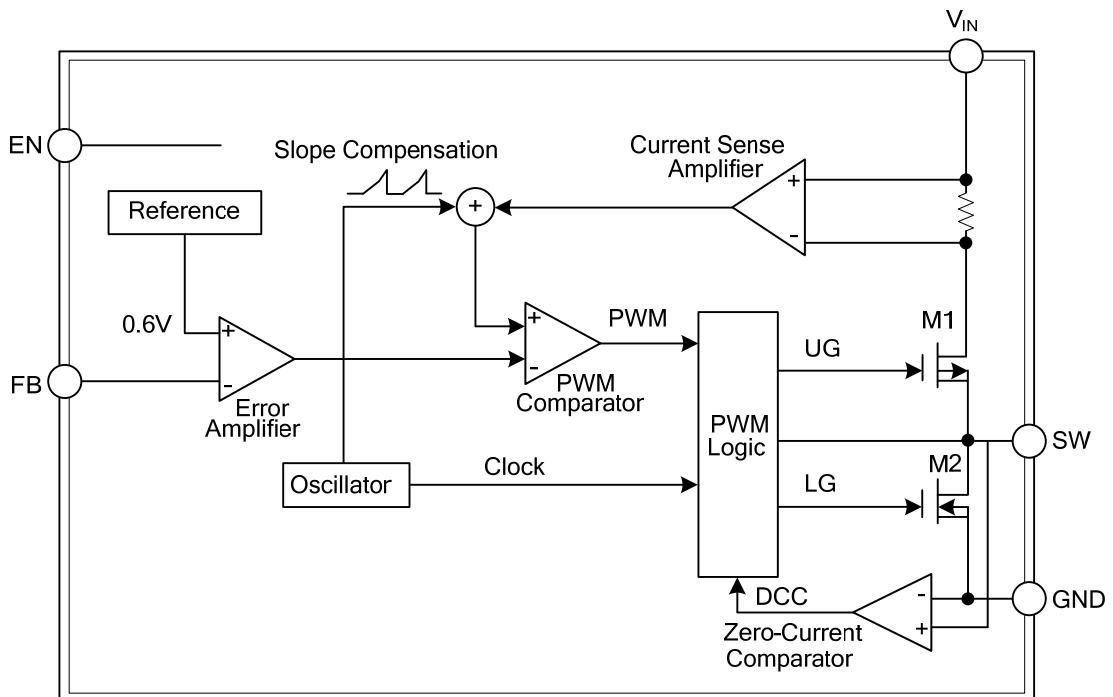

■ ABSOLUTE MAXIMUM RATING (Reference to GND)

PARAMETER	SYMBOL	RATINGS	UNIT
Input Supply Voltage	$V_{IN}$	GND-0.3 ~ 6.5	V
EN, FB Voltage		-0.3 ~ $V_{IN}$	V
Power Dissipation	$P_D$	0.48	W
Junction Temperature Range	$T_J$	-40 ~ +150	°C
Storage Temperature Range	$T_{STG}$	-65 ~ +150	°C

Note: Absolute maximum ratings are those values beyond which the device could be permanently damaged. Absolute maximum ratings are stress ratings only and functional device operation is not implied.

■ RECOMMENDED OPERATING CONDITIONS (Note 1)

PARAMETER	SYMBOL	RATINGS	UNIT
Input Voltage	$V_{IN}$	2.5 ~ 6	V
Operating Temperature Range		-40 ~ +85	°C

■ THERMAL CHARACTERISTICS

PARAMETER	SYMBOL	RATINGS	UNIT
Junction To Ambient	$\theta_{JA}$	280	°C/W

■ ELECTRICAL CHARACTERISTICS ( $T_A=25^\circ\text{C}$ ,  $V_{IN}=5\text{V}$ , unless otherwise noted.)

PARAMETER	SYMBOL	TEST CONDITIONS	MIN	TYP	MAX	UNIT
Input Supply Voltage	$V_{IN}$		2.5		6.0	V
Quiescent Current		$V_{EN}=V_{IN}$ , $V_{FB}=0.65\text{V}$ , $I_{OUT}=0\text{A}$ , No Switching		40		$\mu\text{A}$
Shutdown Current		$V_{EN}=0\text{V}$		0.1	1.5	$\mu\text{A}$
Regulated Feedback Voltage	$V_{REF}$	$T_A=25^\circ\text{C}$	0.588	0.6	0.612	V
Feedback Current			-30		30	nA
$V_{IN}$ Under Voltage Lockout Threshold		$V_{IN}$ Rising		2.0		V
		$V_{IN}$ Falling		1.9		V
PMOSFET On Resistance		$I_{SW}=100\text{mA}$ , $V_{IN}=5\text{V}$		170		$\text{m}\Omega$
NMOSFET On Resistance		$I_{SW}=-100\text{mA}$ , $V_{IN}=5\text{V}$		150		$\text{m}\Omega$
PMOSFET Current Limit		$V_{IN}=3.3\text{V}$		2.5		A
SW Leakage Current		$V_{EN}=0\text{V}$ , $V_{IN}=6.0\text{V}$ $V_{SW}=0\text{V}$ or $6.0\text{V}$	-1		1	$\mu\text{A}$
Oscillator Frequency		$I_{OUT}=1\text{A}$		2.25		MHz
Min. On-Time for HS Switch				80		ns
Maximum Duty		$V_{FB}<0.6\text{V}$			100	%
EN On Threshold			1.5			V
EN Off Threshold					0.4	V
EN Input Current		$V_{EN}=0\text{V}$ to $V_{IN}$	-1		1	$\mu\text{A}$
Soft Start Time				0.32		ms
Thermal Shutdown Threshold				160		°C

## ■ APPLICATION INFORMATION (Cont.)

**Output Voltage**

The output voltage is set using the FB pin and a resistor divider connected to the output as shown in AP Circuit below. The output voltage ( $V_{OUT}$ ) can be calculated according to the voltage of the FB pin ( $V_{FB}$ ) and ratio of the feedback resistors by the following equation, where ( $V_{FB}$ ) is 0.6V:

$$V_{FB} = V_{OUT} \times \frac{R_2}{(R_1 + R_2)}$$

Thus the output voltage is:

$$V_{OUT} = 0.6 \times \frac{(R_1 + R_2)}{R_2}$$

Choose  $R_1=100k\Omega\sim 200k\Omega$  to ensure feedback loop noise immunity. It is optional to add a feed-forward capacitor  $C_{FF}=22\sim 33pF$  in parallel with  $R_1$  to achieve better transient response performance.

■ TYPICAL APPLICATION CIRCUIT

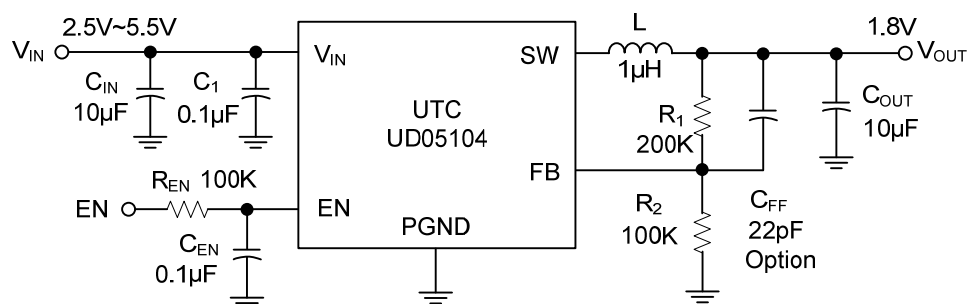

EVB BOM

Qty	Ref	Value	
2	C <sub>IN</sub> , C <sub>OUT</sub>	10µF	
2	C <sub>1</sub> , C <sub>EN</sub>	0.1µF	
1	C <sub>FF</sub>	22pF Option	
1	L	1µH	
1	R1	V <sub>OUT</sub> =3.3V	200KΩ
		V <sub>OUT</sub> =2.5V	187KΩ
		V <sub>OUT</sub> =1.8V	200KΩ
		V <sub>OUT</sub> =1.2V	100KΩ
		V <sub>OUT</sub> =1V	66.5KΩ
1	R2	V <sub>OUT</sub> =3.3V	44.2KΩ
		V <sub>OUT</sub> =2.5V	59KΩ
		V <sub>OUT</sub> =1.8V	100KΩ
		V <sub>OUT</sub> =1.2V	100KΩ
		V <sub>OUT</sub> =1V	100KΩ
1	R <sub>EN</sub>	100KΩ	

UTC assumes no responsibility for equipment failures that result from using products at values that exceed, even momentarily, rated values (such as maximum ratings, operating condition ranges, or other parameters) listed in products specifications of any and all UTC products described or contained herein. UTC products are not designed for use in life support appliances, devices or systems where malfunction of these products can be reasonably expected to result in personal injury. Reproduction in whole or in part is prohibited without the prior written consent of the copyright owner. The information presented in this document does not form part of any quotation or contract, is believed to be accurate and reliable and may be changed without notice.