



UT136E

TRIAC

TRIAC

DESCRIPTION

Passivated, sensitive gate triacs in a plastic envelope, suitable for surface mounting, intended for use in general purpose bidirectional switching and phase control applications, where high sensitivity is required in all four quadrants.

SYMBOL

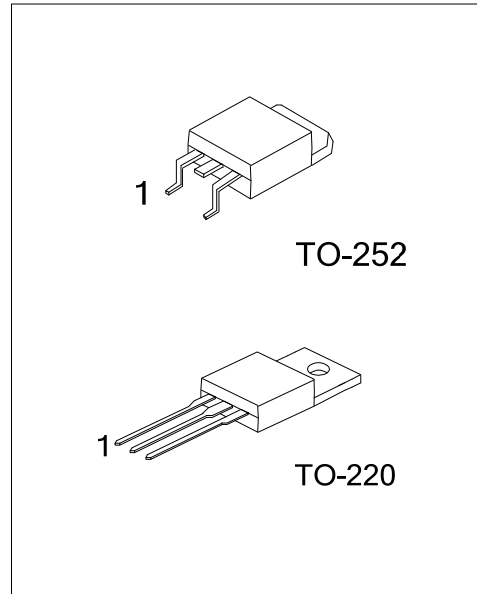
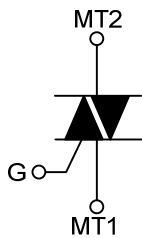

ORDERING INFORMATION

Ordering Number		Package	Pin Assignment			Packing
Lead Free	Halogen Free		1	2	3	
UT136EL-x-TA3-T	UT136EG-x-TA3-T	TO-220	MT1	MT2	G	Tube
UT136EL-x-TN3-R	UT136EG-x-TN3-R	TO-252	MT1	MT2	G	Tape Reel

<p>UT136EG-x-TA3-R</p> <p>(1)Packing Type (2)Package Type (3)Peak Voltage (4)Green Package</p>	<p>(1) T: Tube, R: Tape Reel (2) TA3: TO-220, TN3: TO-252 (3) 5: 500V, 6: 600V, 8: 800V (4) G: Halogen Free and Lead Free, L: Lead Free</p>
--	---

MARKING

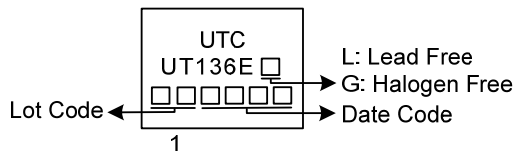

■ ABSOLUTE MAXIMUM RATINGS

PARAMETER		SYMBOL	RATINGS	UNIT	
Repetitive Peak Off-State Voltages	UT136E-5	V_{DRM}	500 (Note 2)	V	
	UT136E-6		600 (Note 2)	V	
	UT136E-8		800	V	
RMS On-State Current (full sine wave, $T_{MB} \leq 107^\circ\text{C}$)		$I_{T(RMS)}$	4	A	
Non-Repetitive Peak On-State Current (Full sine wave; $T_J=25^\circ\text{C}$ prior to surge)	$t=20\text{ms}$	I_{TSM}	25	A	
	$t=16.7\text{ms}$		27	A	
I^2t for fusing ($t=10\text{ms}$)		I^2t	3.1	A^2s	
Repetitive Rate of Rise of On-State Current After Triggering	$I_{TM}=6\text{A},$ $I_G=0.2\text{A},$ $dI_G/dt=0.2\text{A}/\mu\text{s}$	dI_T/dt	T2+ G+	50	$\text{A}/\mu\text{s}$
			T2+ G-	50	$\text{A}/\mu\text{s}$
			T2- G-	50	$\text{A}/\mu\text{s}$
			T2- G+	10	$\text{A}/\mu\text{s}$
Peak Gate Voltage		V_{GM}	5	V	
Peak Gate Current		I_{GM}	2	A	
Peak Gate Power		P_{GM}	5	W	
Average Gate Power (over any 20 ms period)		$P_{G(AV)}$	0.5	W	
Junction Temperature		T_J	125	$^\circ\text{C}$	
Storage Temperature		T_{STG}	-40 ~ +150	$^\circ\text{C}$	

Note: 1. Absolute maximum ratings are those values beyond which the device could be permanently damaged.

Absolute maximum ratings are stress ratings only and functional device operation is not implied.

2. Although not recommended, off-state voltages up to 800V may be applied without damage, but the triac may switch to the on-state. The rate of rise of current should not exceed $3\text{A}/\mu\text{s}$.

■ THERMAL DATA

PARAMETER		SYMBOL	RATINGS	UNIT
Junction to Ambient	Pcb Mounted	TO-220	60	K/W
		TO-252	75	
Junction to Mounting Base		Full Cycle	3.0	K/W
		Half Cycle	3.7	

■ ELECTRICAL CHARACTERISTICS ($T_J=25^\circ\text{C}$, unless otherwise specified)

PARAMETER	SYMBOL	TEST CONDITIONS	MIN	TYP	MAX	UNIT
STATIC						
Gate Trigger Current	I_{GT}	$V_D=12\text{V}, I_T=0.1\text{A}$	T2+ G+	2.5	10	mA
			T2+ G-	4.0	10	mA
			T2- G-	5.0	10	mA
			T2- G+	11	25	mA
Latching Current	I_L	$V_D=12\text{V}, I_{GT}=0.1\text{A}$	T2+ G+	3.0	15	mA
			T2+ G-	10	20	mA
			T2- G-	2.5	15	mA
			T2- G+	4.0	20	mA
Holding Current	I_H	$V_D=12\text{V}, I_{GT}=0.1\text{A}$		2.2	15	mA
On-State Voltage	V_T	$I_T=5\text{A}$		1.4	1.7	V
Gate Trigger Voltage	V_{GT}	$V_D=12\text{V}, I_T=0.1\text{A}$		0.7	1.5	V
		$V_D=400\text{V}, I_T=0.1\text{A}, T_J=125^\circ\text{C}$	0.25	0.4		V
Off-State Leakage Current	I_D	$V_D=V_{DRM(MAX)}, T_J=125^\circ\text{C}$		0.1	0.5	mA
DYNAMIC						
Critical Rate of Rise of Off-State Voltage	dV_D/dt	$V_{DM}=67\%V_{DRM(MAX)}, T_J=125^\circ\text{C},$ exponential waveform; gate open circuit		50		$\text{V}/\mu\text{s}$
Gate Controlled Turn-On Time	t_{GT}	$I_{TM}=6\text{A}, V_D=V_{DRM(MAX)}, I_G=0.1\text{A}, dI_G/dt=5\text{A}/\mu\text{s}$		2		μs

TYPICAL CHARACTERISTICS

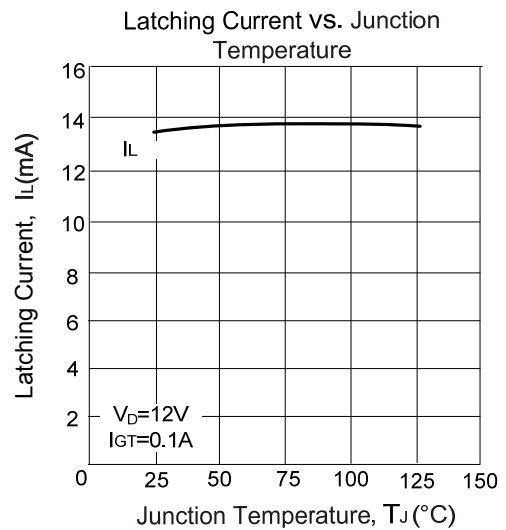
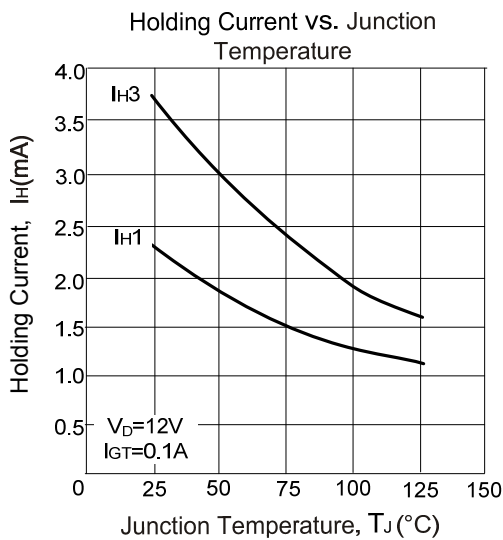
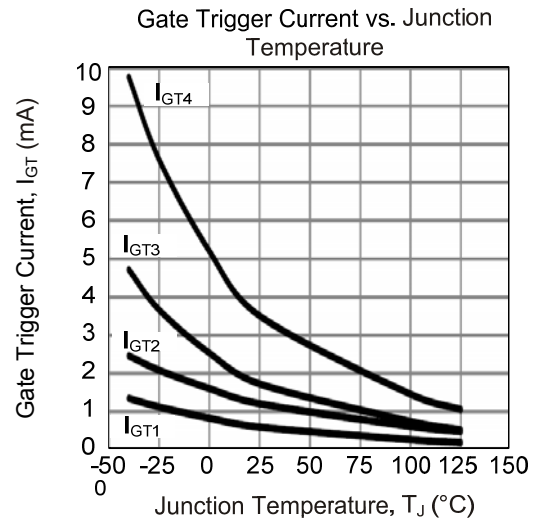
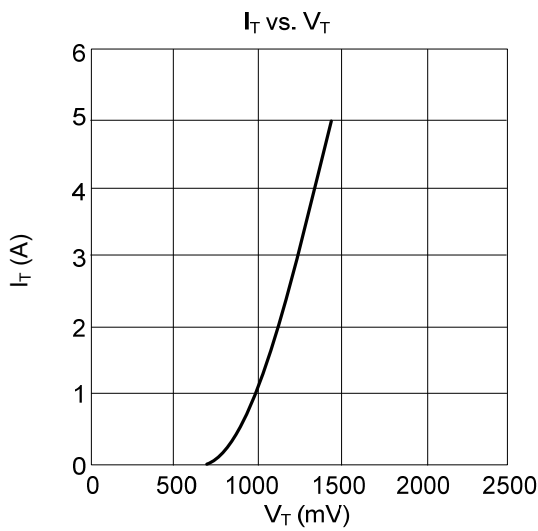
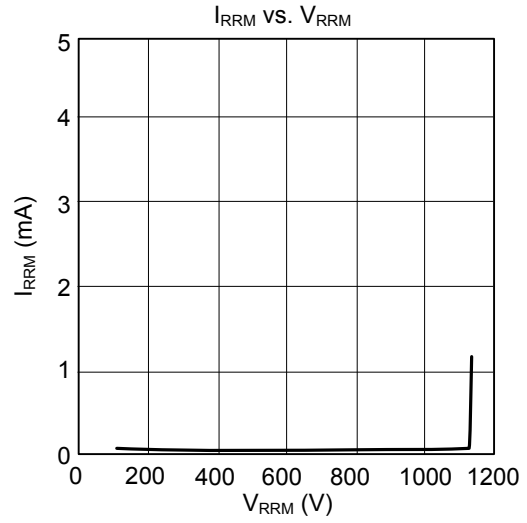
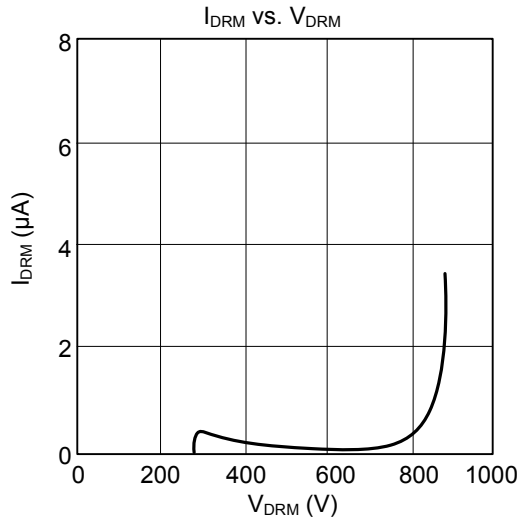

■ TYPICAL CHARACTERISTICS (Cont.)

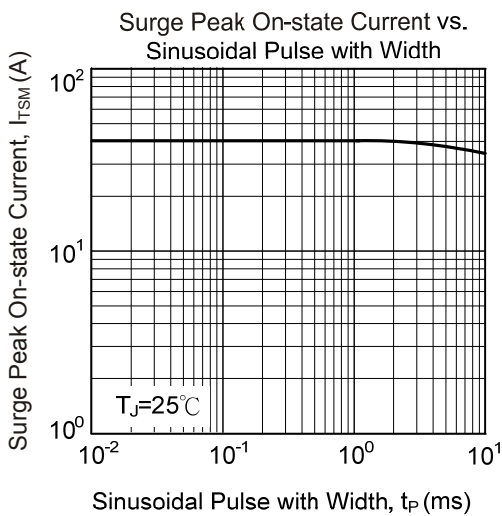
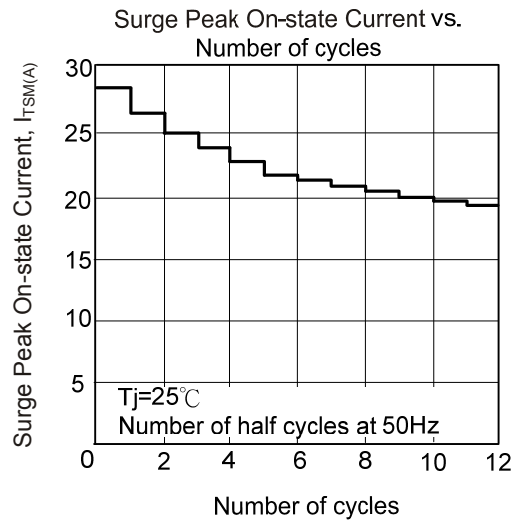
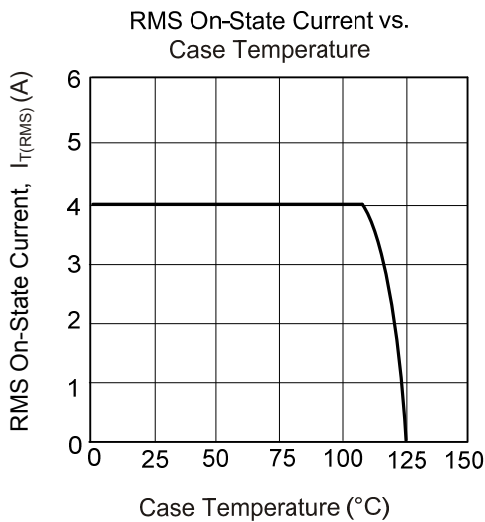
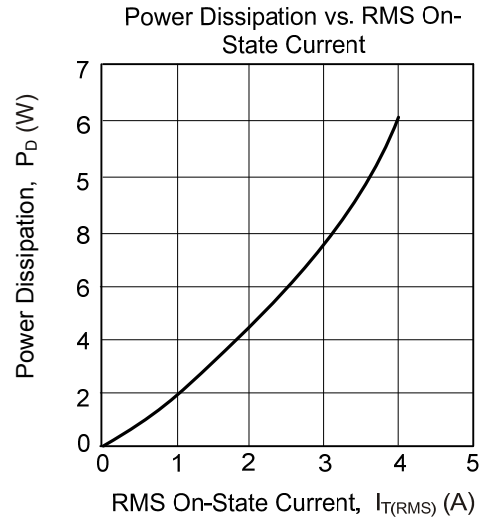
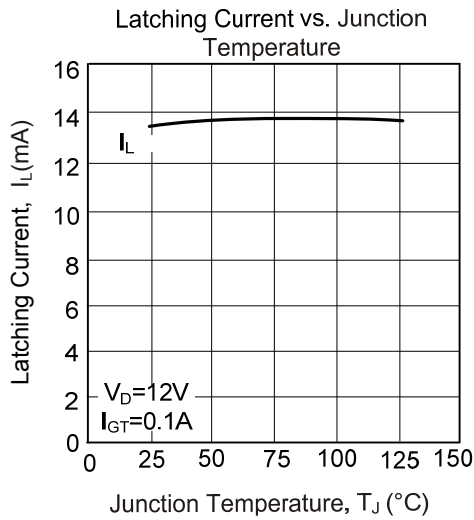

UTC assumes no responsibility for equipment failures that result from using products at values that exceed, even momentarily, rated values (such as maximum ratings, operating condition ranges, or other parameters) listed in products specifications of any and all UTC products described or contained herein. UTC products are not designed for use in life support appliances, devices or systems where malfunction of these products can be reasonably expected to result in personal injury. Reproduction in whole or in part is prohibited without the prior written consent of the copyright owner. UTC reserves the right to make changes to information published in this document, including without limitation specifications and product descriptions, at any time and without notice. This document supersedes and replaces all information supplied prior to the publication hereof.