



UM611

Preliminary

LINEAR INTEGRATED CIRCUIT

DOUBLE CONSTANT VOLTAGE CONTROLLERS

DESCRIPTION

The UTC **UM611** is a highly integrated solution for double constant voltage application.

The UTC **UM611** contains two voltage reference (0.6V and 0.8V) and two operational amplifiers. The 0.8V voltage reference, combined with one operational amplifier, makes of an ideal voltage controller for use in adapters and battery chargers. The 0.6 voltage reference, combined with another operational amplifier, makes of an ideal current limiter for use in adapters and battery chargers.

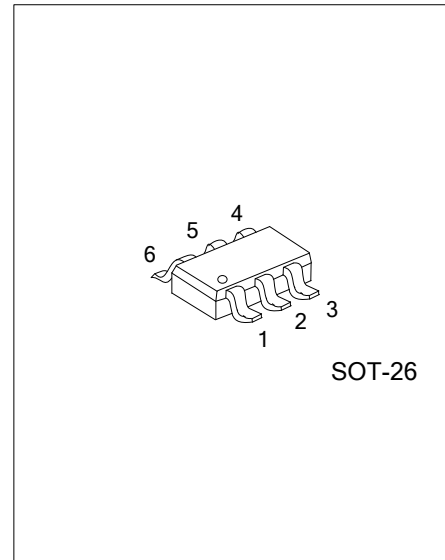

FEATURES

- * Constant voltage control
- * Low supply current: 0.45mA ($V_{CC}=5V$)
- * Easy compensation
- * Precision Internal Voltage Reference: 0.6V/0.8V
- * Low external component
- * Operating power supply : 3V~20V

APPLICATION

- * battery chargers
- * DCDC application
- * ACDC adapters

ORDERING INFORMATION

Ordering Number		Package	Packing
Lead Free	Halogen Free		
UM611L-S16-R	UM611G-S16-R	SOT-26	Tape Reel

<p>UM611G-AG6-R</p> <p>(1) Packing Type</p> <p>(2) Package Type</p> <p>(3) Green Package</p>	<p>(1) T: Tape Reel</p> <p>(2) AG6: SOT-26</p> <p>(3) G: Halogen Free and Lead Free, L: Lead Free</p>
--	---

MARKING

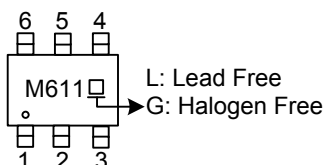

■ PIN CONFIGURATION

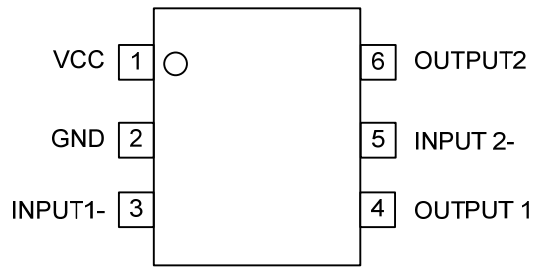

■ PIN DESCRIPTION

PIN NO.	PIN NAME	DESCRIPTION
1	V _{CC}	Supply Voltage
2	GND	Ground
3	INPUT 1-	Inverting Input of Channel 1
4	OUTPUT 1	Output of Channel 1
5	INPUT 2-	Inverting Input of Channel 2
6	OUTPUT 2	Output of Channel 2

■ BLOCK DIAGRAM

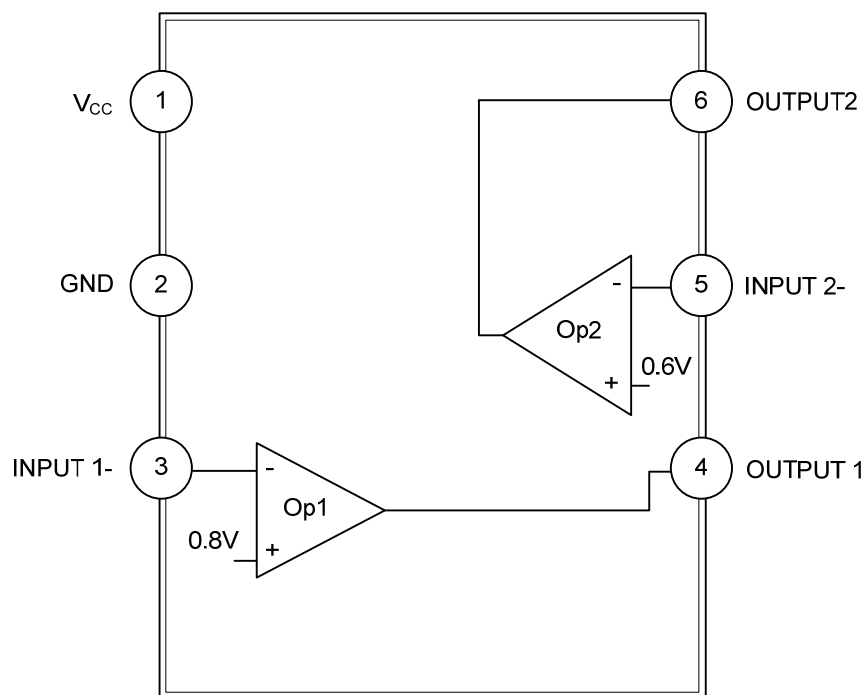

■ ABSOLUTE MAXIMUM RATING

PARAMETER	SYMBOL	RATINGS	UNIT
Power Supply Voltage (V_{CC} to GND)	V_{CC}	20	V
Op Amp 1 and 2 Input Voltage Range	V_{IN}	-0.3 ~ $V_{CC}+0.3$	V
Operating Junction Temperature	T_J	+150	°C
Storage Temperature Range	T_{STG}	-55 ~ +150	°C

Note: Absolute maximum ratings are those values beyond which the device could be permanently damaged. Absolute maximum ratings are stress ratings only and functional device operation is not implied.

■ RECOMMENDED OPERATING CONDITIONS

PARAMETER	SYMBOL	RATING	UNIT
Supply Voltage	V_{CC}	3 ~ 20	V
Ambient Temperature	T_A	-40 ~ +105	°C

■ ELECTRICAL CHARACTERISTICS

(Operating Conditions: $V_{CC}=+5V$, $T_A=25^\circ C$ unless otherwise specified)

PARAMETER	SYMBOL	TEST CONDITIONS	MIN	TYP.	MAX	UNIT
Total Supply Current	I_{CC}	$V_{CC}=5V$, no load, $-40^\circ C \leq T_A \leq 105^\circ C$		0.45	0.75	mA
		$V_{CC}=20V$, no load, $-40^\circ C \leq T_A \leq 105^\circ C$		2.2	3.6	mA
Reference Voltage 1	V_{REF1}	$T_A=25^\circ C$	0.793	0.800	0.807	V
		$-40^\circ C \leq T_A \leq 105^\circ C$	0.790	0.800	0.810	V
Reference Voltage 2	V_{REF2}	$T_A=25^\circ C$	0.595	0.600	0.605	V
		$-40^\circ C \leq T_A \leq 105^\circ C$	0.593	0.600	0.607	V
Output Current	Source	I_{SOURCE}	$V_{CC}=15V$, $V_{ID}=0.5V$, $V_O=2V$	17	20	mA
	Sink	I_{SINK}	$V_{CC}=15V$, $V_{ID}=-0.5V$, $V_O=2V$	7	12	mA
Output Voltage Swing (High)	V_{OH}	$V_{CC}=20V$, $R_L=10k\Omega$, $V_{ID}=0.5V$	17	18		V
Output Voltage Swing (Low)	V_{OL}	$V_{CC}=20V$, $R_L=10k\Omega$, $V_{ID}=-0.5V$		17	100	mV
Slew Rate	SR	$V_{CC}=18V$, $R_L=2k\Omega$, $A_V=-1$, $V_{IN}=0.5\sim 2V$, $C_L=100pF$	0.2	1.0		V/ μs
Unity Gain Bandwidth	GBP	$V_{CC}=18V$, $R_L=2k\Omega$, $C_L=100pF$	0.7	1.0		MHz

UTC assumes no responsibility for equipment failures that result from using products at values that exceed, even momentarily, rated values (such as maximum ratings, operating condition ranges, or other parameters) listed in products specifications of any and all UTC products described or contained herein. UTC products are not designed for use in life support appliances, devices or systems where malfunction of these products can be reasonably expected to result in personal injury. Reproduction in whole or in part is prohibited without the prior written consent of the copyright owner. UTC reserves the right to make changes to information published in this document, including without limitation specifications and product descriptions, at any time and without notice. This document supersedes and replaces all information supplied prior to the publication hereof.