

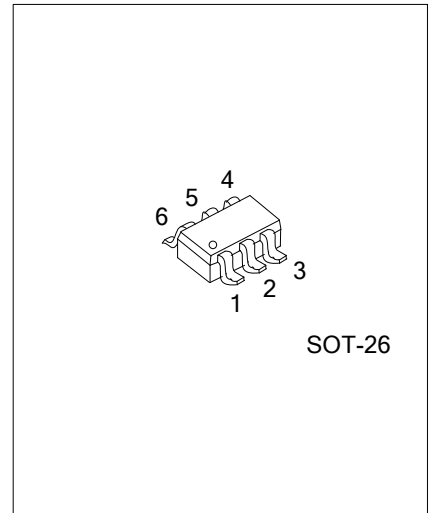

UM610/A

LINEAR INTEGRATED CIRCUIT

CONSTANT VOLTAGE AND CONSTANT CURRENT CONTROLLER



DESCRIPTION

The UTC **UM610/A** is a monolithic IC that includes one 2.5V voltage reference and two operational amplifiers.

This device is offering space and cost saving in many applications like power supply management or switching battery chargers.

FEATURES

- * Constant voltage and constant current control
- * Low supply current: 190uA
- * Operating power supply range: 3.5V~36V
- * Precision internal voltage reference 2.5V
- * Low current sense threshold: UM610:48mV, UM610A:30mV
- * Easy compensation
- * Low external component count

ORDERING INFORMATION

Ordering Number		Package	Packing
Lead Free	Halogen Free		
UM610L-AG6-R	UM610G-AG6-R	SOT-26	Tape Reel
UM610AL-AG6-R	UM610AG-AG6-R	SOT-26	Tape Reel

<p>UM610AG-AG6-R</p> <ul style="list-style-type: none"> (1) Packing Type (2) Package Type (3) Green Package (4) V_{SENSE}, I_{BI} 	<ul style="list-style-type: none"> (1) R: Tape Reel (2) AG6: SOT-26 (3) G: Halogen Free and Lead Free, L: Lead Free (4) refer to ELECTRICAL CHARACTERISTICS
---	---

MARKING

UM610	UM610A

■ PIN CONFIGURATION

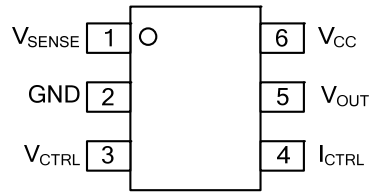

■ PIN DESCRIPTION

PIN NO.	PIN NAME	DESCRIPTION
1	V _{SENSE}	Input pin of the current control loop
2	GND	Ground
3	V _{CTRL}	Input pin of the voltage control loop
4	I _{CTRL}	Input pin of the current control loop
5	V _{OUT}	Output pin. Sinking current only
6	V _{CC}	Power Supply

■ BLOCK DIAGRAM

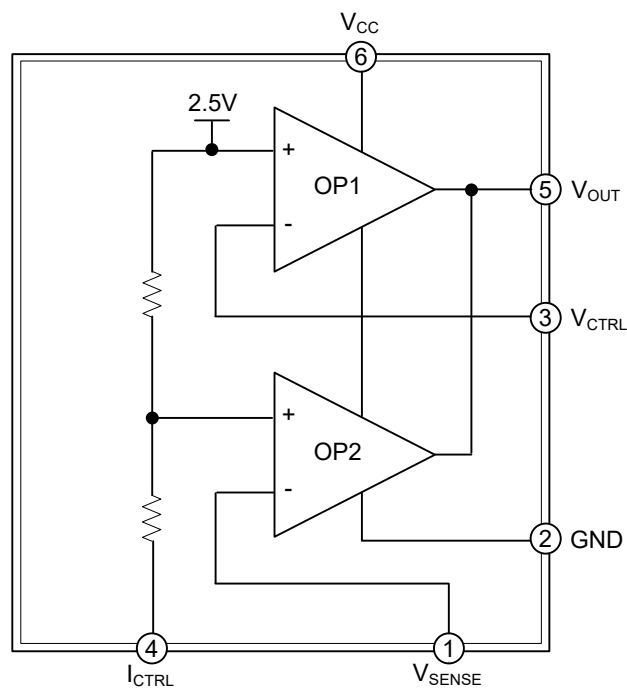

■ ABSOLUTE MAXIMUM RATING

PARAMETER	SYMBOL	RATINGS	UNIT
Power Supply Voltage	V_{CC}	-0.3 ~ 38	V
Input Voltage (V_{OUT} Pin)	V_{OUT}	-0.3 ~ V_{CC}	V
Input Voltage (I_{CTRL} Pin)	V_{ICTRL}	-0.3 ~ 18	V
Input Voltage (V_{SENSE} Pin)	V_{SENSE}	-0.3 ~ 18	V
Input Voltage (V_{CTRL} Pin)	V_{VCTRL}	-0.3 ~ 18	V
Junction Temperature	T_J	+150	°C
Storage Temperature	T_{STG}	-55 ~ +150	°C

Note: Absolute maximum ratings are those values beyond which the device could be permanently damaged. Absolute maximum ratings are stress ratings only and functional device operation is not implied.

■ THERMAL DATA

PARAMETER	SYMBOL	RATINGS	UNIT
Junction to Ambient	θ_{JA}	250	°C/W

■ RECOMMENDED OPERATING CONDITIONS

PARAMETER	SYMBOL	MIN	TYP	MAX	UNIT
Power Supply Voltage	V_{CC}	3.5		36	V

■ ELECTRICAL CHARACTERISTICS

(Operating Conditions: $V_{CC}=20V$, $T_A=25^\circ C$ unless otherwise specified)

PARAMETER	SYMBOL	TEST CONDITIONS	MIN	TYP	MAX	UNIT
Total Current Consumption						
Total Supply Current Not Including the Output Sinking Current	I_{CC}	$V_{ICTRL}=V_{SENSE}=0V$, $V_{OUT}=Open$		190		μA
Voltage Control Loop						
Transconductance Gain (V_{CTRL}). Sink Current Only	Gmv		1.0	3.5		mA/mV
Voltage Control Loop Reference	V_{REF}	$T_A=25^\circ C$	2.488	2.50	2.512	V
		$T_A=-25\sim+125^\circ C$	2.48		2.52	
Input Bias Current (V_{CTRL})	I_{IBV}			25		nA
Current Control Loop						
Transconductance Gain (I_{CTRL}). Sink Current Only	Gmi		1.5	7		mA/mV
Current Control Loop Reference	V_{SENSE}	UM610A ($T_A=25^\circ C$)	29	30	31	mV
		UM610A ($T_A=-25\sim+125^\circ C$)	28	30	32	mV
		UM610 ($T_A=25^\circ C$)	46.5	48	49.5	mV
		UM610 ($T_A=-25\sim+125^\circ C$)	44	48	52	mV
Current Out of Pin I_{CTRL} at V_{SENSE}	I_{IBI}	UM610A, $V_{ICTRL}=-30mV$		16		μA
		UM610, $V_{ICTRL}=-48mV$		16		μA
Output Stage						
Low Output Voltage at 2mA Sinking Current	V_{OL}			30	100	mV
Output Short Circuit Current. Sink Current Only	I_{OS}	$V_{OUT}=4V$		30		mA

■ TYPICAL APPLICATION CIRCUIT

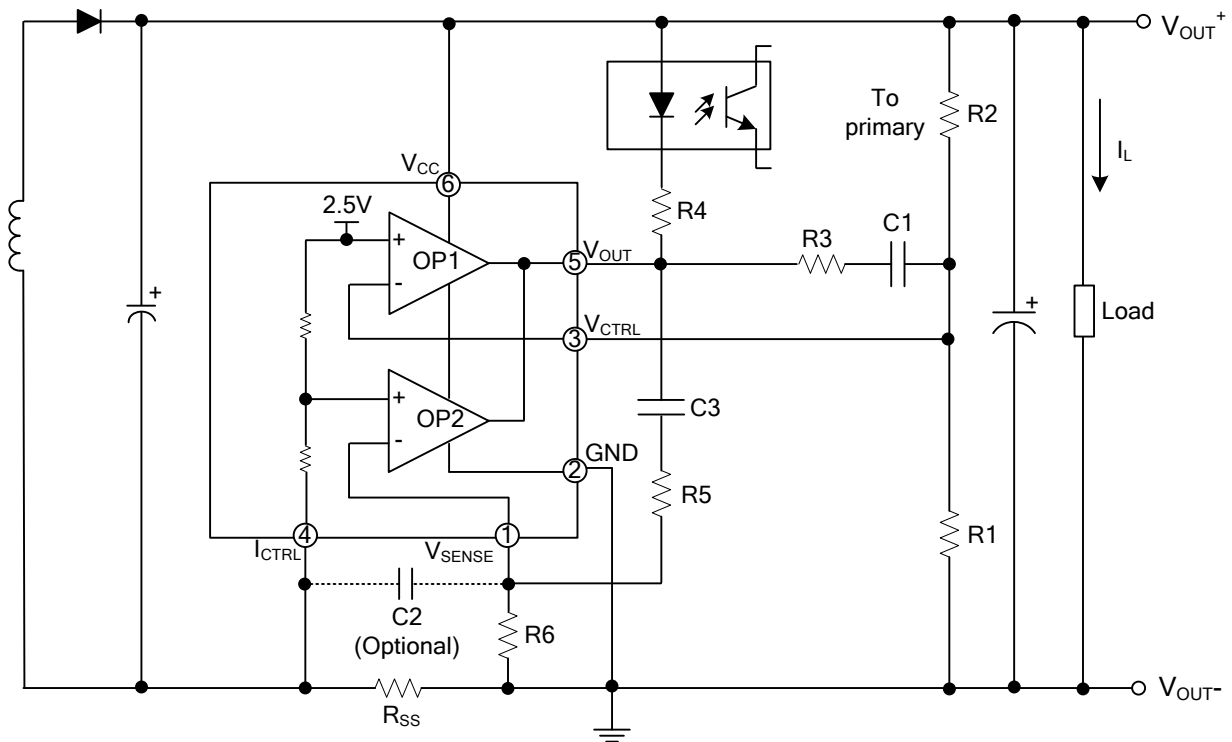

$$V_{OUT} = V_{REF} \times \frac{R1+R2}{R1}$$

$$\text{Current Limit} = \frac{V_{SENSE}}{R_{SS}}$$

Typical Application 1

■ TYPICAL APPLICATION CIRCUIT (Cont.)

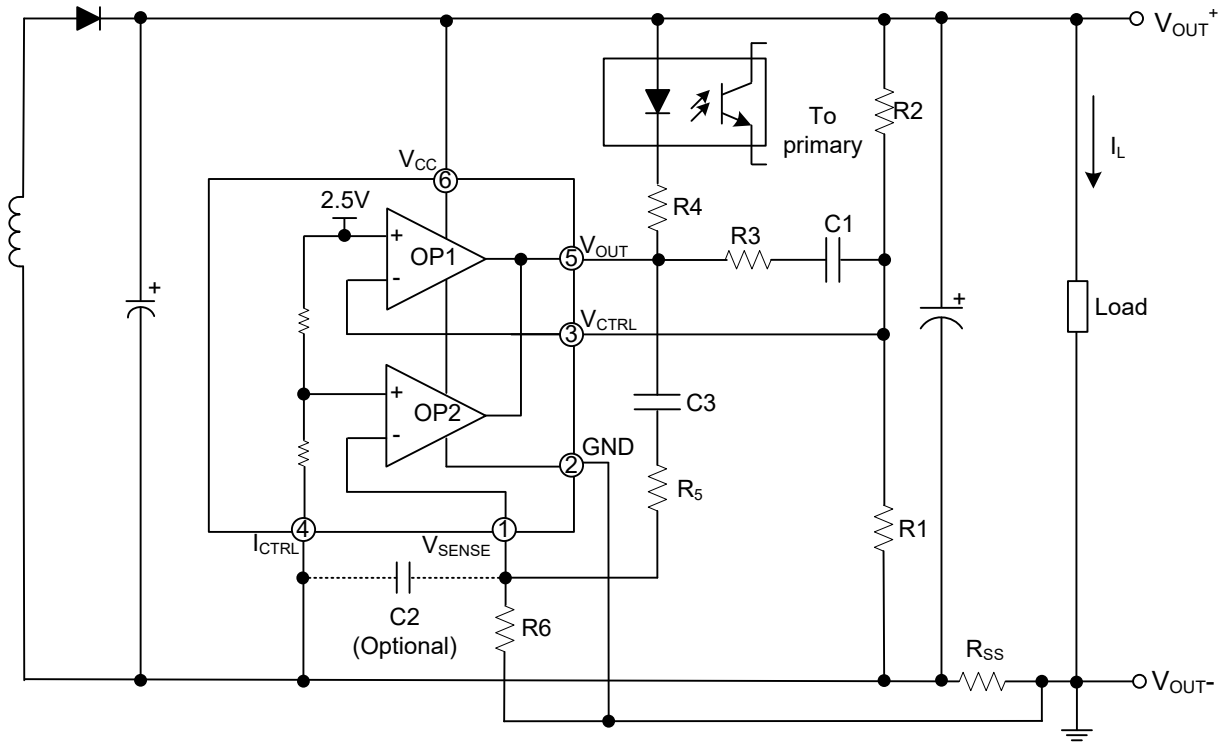

$$V_{OUT} = [V_{REF} + (I_L \times R_{SS})] \times \frac{R1 + R2}{R1} - (I_L \times R_{SS})$$

$$\text{Current Limit} = \frac{V_{SENSE}}{R_{SS}}$$

Typical Application 2

■ TYPICAL APPLICATION CIRCUIT (Cont.)

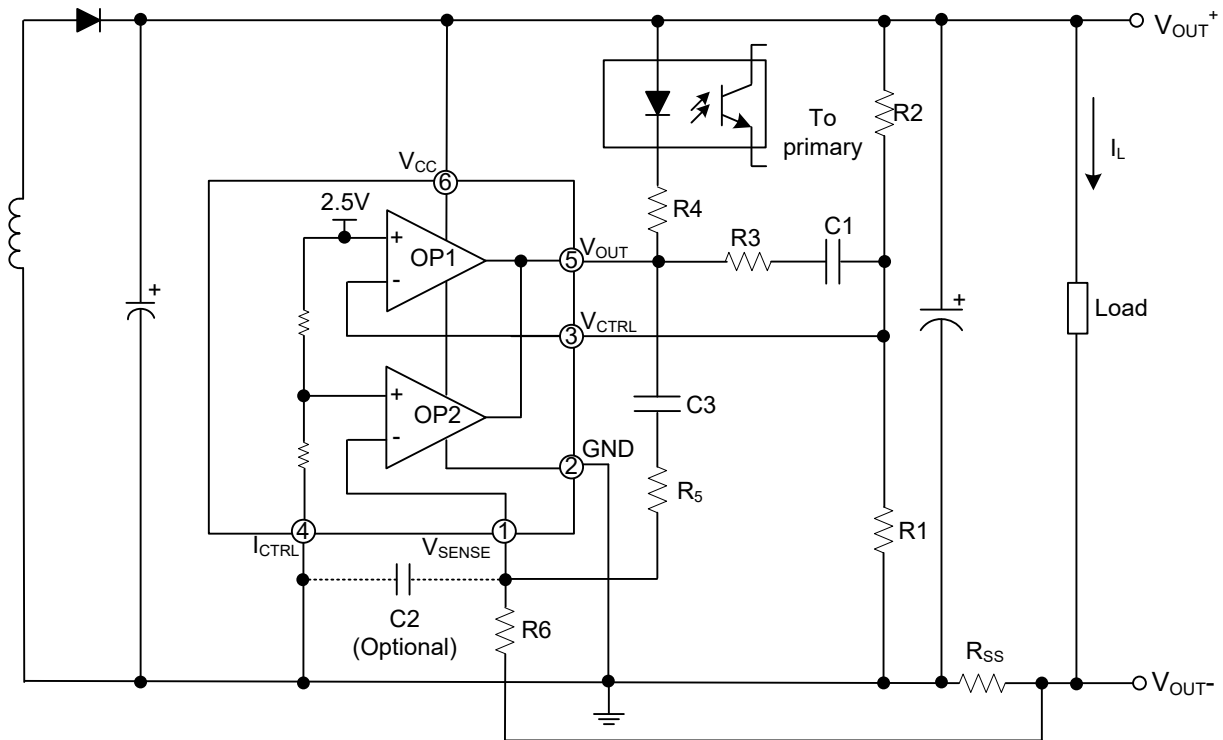

$$V_{OUT} = V_{REF} \times \frac{R1 + R2}{R1} - (I_L \times R_{SS})$$

$$\text{Current Limit} = \frac{V_{SENSE} \times V_{REF}}{(V_{SENSE} + V_{REF}) \times R_{SS}}$$

Typical Application 3

TYPICAL CHARACTERISTICS

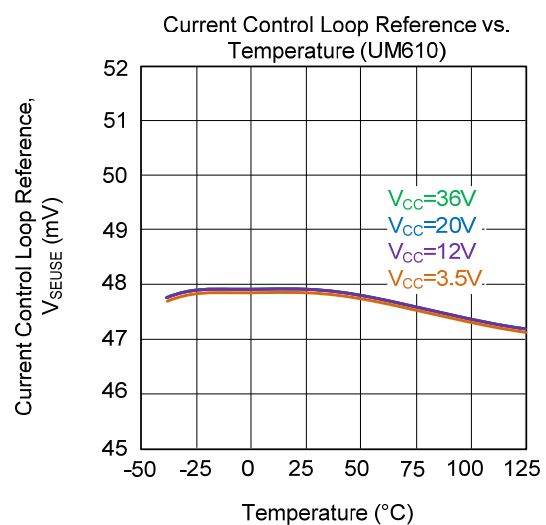
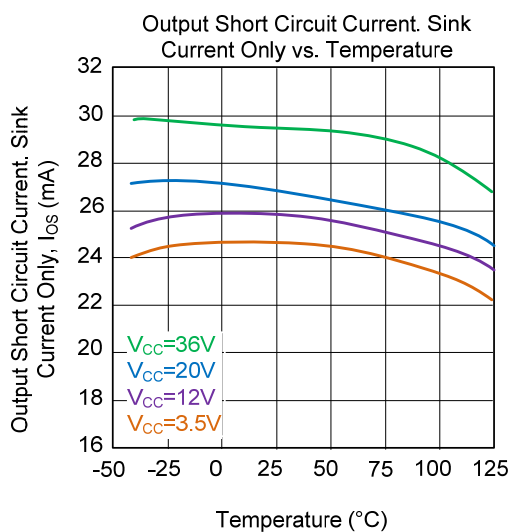
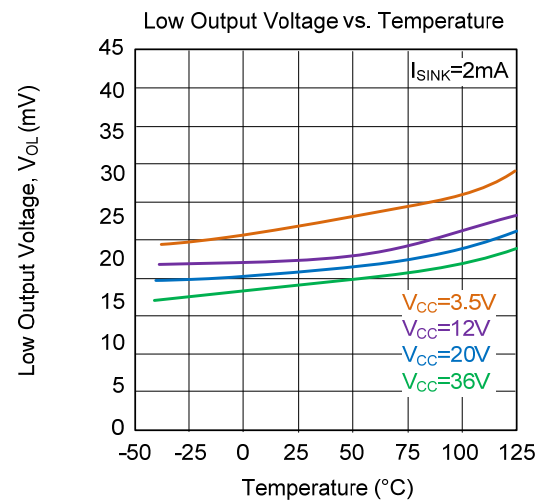
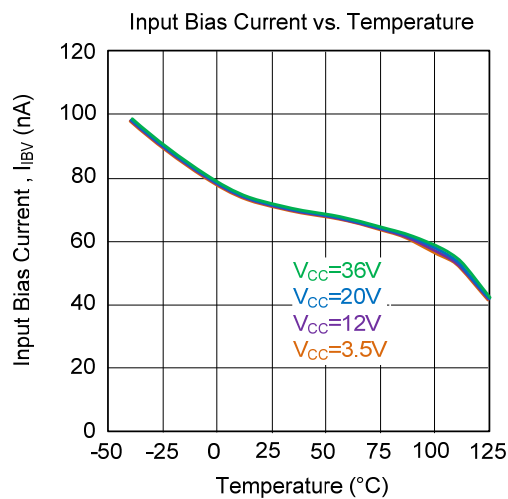
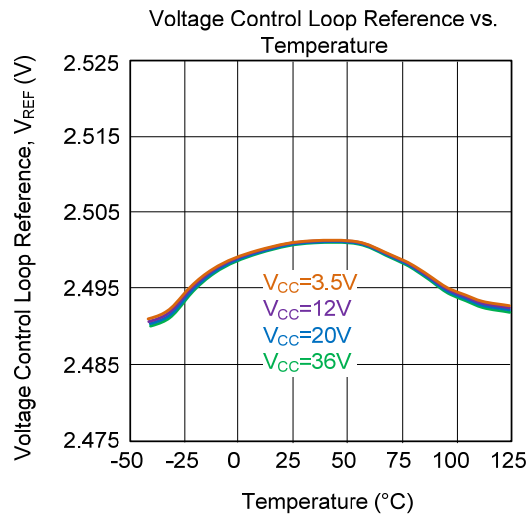
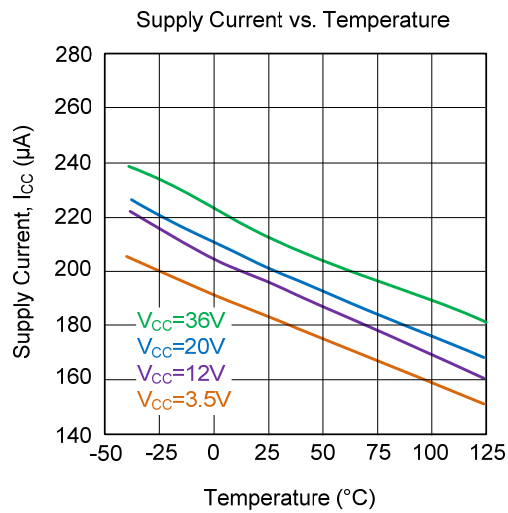

UTC assumes no responsibility for equipment failures that result from using products at values that exceed, even momentarily, rated values (such as maximum ratings, operating condition ranges, or other parameters) listed in products specifications of any and all UTC products described or contained herein. UTC products are not designed for use in life support appliances, devices or systems where malfunction of these products can be reasonably expected to result in personal injury. Reproduction in whole or in part is prohibited without the prior written consent of the copyright owner. UTC reserves the right to make changes to information published in this document, including without limitation specifications and product descriptions, at any time and without notice. This document supersedes and replaces all information supplied prior to the publication hereof.