



UR75XX

CMOS IC

HIGH VOLTAGE , ULTRA LOW IQ VOLTAGE REGULATOR

DESCRIPTION

The UTC **UR75XX** Series are a low dropout regulator with wide input voltage range, high output voltage accuracy, ultra low quiescent current and low dropout. This regulator is based on a CMOS process, and it's input voltage could high enough more than 36V, thus they are very suitable for high voltage application.

FEATURES

- * High output voltage accuracy: $\pm 2\%$
- * Ultra low quiescent current: 1.2uA (Typ.)
- * Low temperature-drift coefficient of V_{OUT} : $\pm 50\text{ppm}/^\circ\text{C}$ (Typ.)
- * Wide Input voltage range: 0 ~ 36V

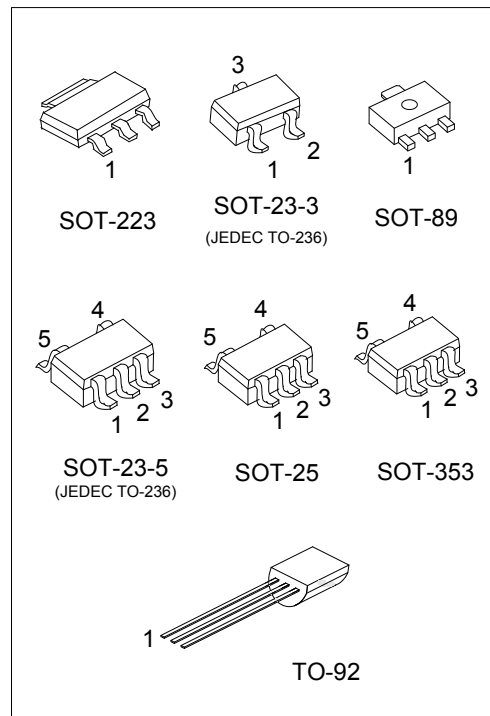

ORDERING INFORMATION

Ordering Number		Package	Pin Assignment					Packing
Lead Free	Halogen Free		1	2	3	4	5	
UR75XXL-AA3-R	UR75XXG-AA3-R	SOT-223	G	I	O	-	-	Tape Reel
UR75XXL-AB3-R	UR75XXG-AB3-R	SOT-89	G	I	O	-	-	Tape Reel
UR75XXL-AE2-1-R	UR75XXG-AE2-1-R	SOT-23-3	G	I	O	-	-	Tape Reel
UR75XXL-AE2-2-R	UR75XXG-AE2-2-R	SOT-23-3	O	I	G	-	-	Tape Reel
UR75XXL-AE2-3-R	UR75XXG-AE2-3-R	SOT-23-3	G	O	I	-	-	Tape Reel
UR75XXL-AE2-4-R	UR75XXG-AE2-4-R	SOT-23-3	I	O	G	-	-	Tape Reel
UR75XXL-AE5-C-R	UR75XXG-AE5-C-R	SOT-23-5	I	G	N	N	O	Tape Reel
UR75XXL-AE5-F-R	UR75XXG-AE5-F-R	SOT-23-5	G	I	O	N	N	Tape Reel
UR75XXL-AF5-C-R	UR75XXG-AF5-C-R	SOT-25	I	G	N	N	O	Tape Reel
UR75XXL-AF5-F-R	UR75XXG-AF5-F-R	SOT-25	G	I	O	N	N	Tape Reel
UR75XXL-AL5-C-R	UR75XXG-AL5-C-R	SOT-353	I	G	N	N	O	Tape Reel
UR75XXL-T92-B	UR75XXG-T92-B	TO-92	G	I	O	-	-	Tape Box
UR75XXL-T92-K	UR75XXG-T92-K	TO-92	G	I	O	-	-	Bulk

Note: Pin assignment: G: Ground I: V_{IN} O: V_{OUT} N: NC

<p>UR75XXG-AE2-1-R</p> <p>(1) Packing Type (2) Pin Assignment (3) Package Type (4) Green Package (5) Output Voltage Code</p>	<p>(1) R: Tape Reel, B: Tape Box, K: Bulk (2) refer to Pin Assignment (3) AA3: SOT-223, AB3: SOT-89, AE2: SOT-23-3 AE5: SOT-23-5, AF5: SOT-25, AL5: SOT-353 T92: TO-92 (4) G: Halogen Free and Lead Free, L: Lead Free (5) XX: Refer to Marking Information</p>
--	---

MARKING INFORMATION

PACKAGE	VOLTAGE CODE	MARKING
SOT-223		<p>Voltage Code ← UR75XX□ → Date Code L: Lead Free G: Halogen Free</p>
SOT-89	15: 1.5V 18: 1.8V 21: 2.1V 23: 2.3V 25: 2.5V 27: 2.7V	<p>Date Code ← □□□□ UR75XX□ → L: Lead Free G: Halogen Free</p>
SOT-23-3	30: 3.0V 33: 3.3V 36: 3.6V 40: 4.0V 44: 4.4V	<p>Voltage Code ← 75XXX□ → Pin Code</p>
SOT-23-5 SOT-25 SOT-353	50: 5.0V 60: 6.0V 70: 7.0V 80: 8.0V 90: 9.0V 10: 10V 12: 12V	<p>Voltage Code ← 75XXX□ → Pin Code</p>
TO-92		<p>Voltage Code ← UTC UR75XX□ → Date Code L: Lead Free G: Halogen Free</p>

■ BLOCK DIAGRAM

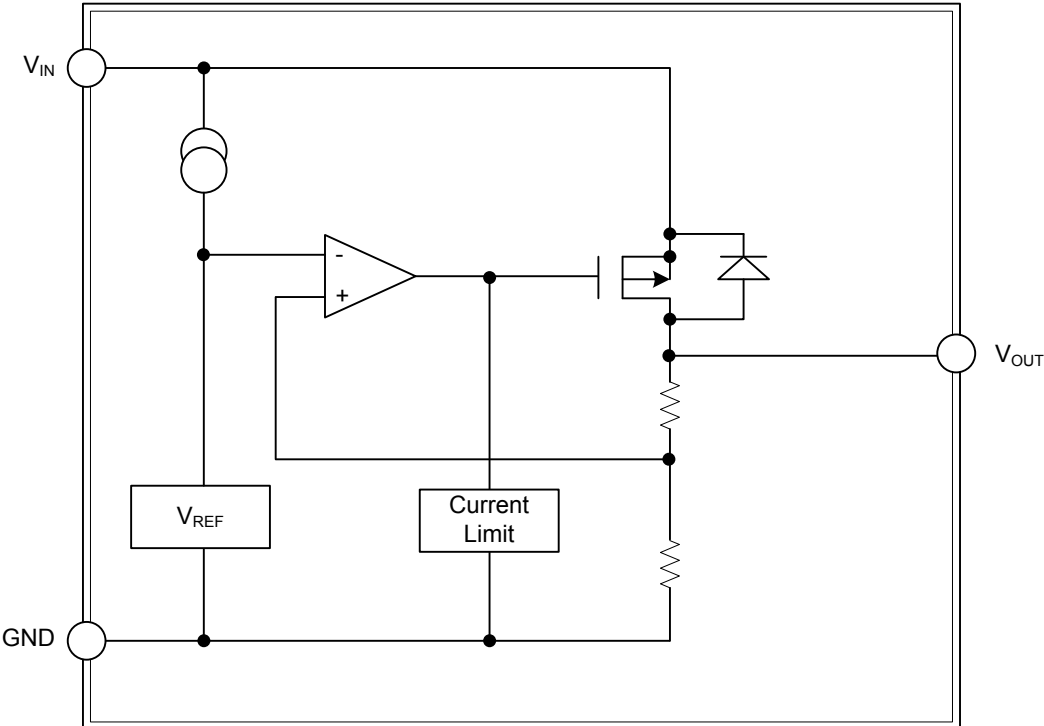

■ ABSOLUTE MAXIMUM RATING

PARAMETER		SYMBOL	RATINGS	UNIT
Input Voltage		V_{IN}	36	V
Power Dissipation	SOT-223	P_D	600	mW
	SOT-23-3		250	mW
	SOT-23-5		300	mW
	SOT-25			
	SOT-353			
SOT-89/TO-92	500	mW		
Operating Temperature Range		T_{OPR}	-40 ~ +125	°C
Storage Temperature Range		T_{STG}	-40 ~ +125	°C

Note: Absolute maximum ratings are those values beyond which the device could be permanently damaged. Absolute maximum ratings are stress ratings only and functional device operation is not implied.

■ ELECTRICAL CHARACTERISTICS ($T_A=25^\circ\text{C}$, unless otherwise specified)

UTC UR7515

PARAMETER	SYMBOL	TEST CONDITIONS	MIN	TYP	MAX	UNIT
Output Voltage	V_{OUT}	$V_{IN}=V_{OUT}+2V, I_{OUT}=10\text{mA}$	1.47	1.5	1.53	V
Output Current (Note 1)	I_{OUT}	$V_{IN}=V_{OUT}+2V$	70	100		mA
Dropout Voltage (Note 2)	V_{DROP}	$I_{OUT}=1\text{mA}$		45	100	mV
Line Regulation	$\frac{\Delta V_{OUT1}}{\Delta V_{IN} \cdot V_{OUT}}$	$V_{OUT}+2V \leq V_{IN} \leq 36V, I_{OUT}=1\text{mA}$		0.05	0.2	%/V
Load Regulation	ΔV_{OUT2}	$V_{IN}=V_{OUT}+2V, 1.0\text{mA} \leq I_{OUT} \leq 50\text{mA}$		30	80	mV
Output Voltage Temperature Coefficient	$\frac{\Delta V_{OUT1}}{T_A \cdot V_{OUT}}$	$V_{IN}=V_{OUT}+2V, I_{OUT}=10\text{mA}, -40^\circ\text{C} \leq T_A \leq 85^\circ\text{C}$		±50	±100	Ppm/°C
Supply Current	I_{SS1}	$V_{IN}=V_{OUT}+2V$		1.2	3.0	uA

UTC UR7518

PARAMETER	SYMBOL	TEST CONDITIONS	MIN	TYP	MAX	UNIT
Output Voltage	V_{OUT}	$V_{IN}=V_{OUT}+2V, I_{OUT}=10\text{mA}$	1.764	1.8	1.836	V
Output Current (Note 1)	I_{OUT}	$V_{IN}=V_{OUT}+2V$	70	100		mA
Dropout Voltage (Note 2)	V_{DROP}	$I_{OUT}=1\text{mA}$		45	100	mV
Line Regulation	$\frac{\Delta V_{OUT1}}{\Delta V_{IN} \cdot V_{OUT}}$	$V_{OUT}+2V \leq V_{IN} \leq 36V, I_{OUT}=1\text{mA}$		0.05	0.2	%/V
Load Regulation	ΔV_{OUT2}	$V_{IN}=V_{OUT}+2V, 1.0\text{mA} \leq I_{OUT} \leq 50\text{mA}$		30	80	mV
Output Voltage Temperature Coefficient	$\frac{\Delta V_{OUT1}}{T_A \cdot V_{OUT}}$	$V_{IN}=V_{OUT}+2V, I_{OUT}=10\text{mA}, -40^\circ\text{C} \leq T_A \leq 85^\circ\text{C}$		±50	±100	Ppm/°C
Supply Current	I_{SS1}	$V_{IN}=V_{OUT}+2V$		1.2	3.0	uA

UTC UR7521

PARAMETER	SYMBOL	TEST CONDITIONS	MIN	TYP	MAX	UNIT
Output Voltage	V_{OUT}	$V_{IN}=V_{OUT}+2V, I_{OUT}=10\text{mA}$	2.058	2.1	2.142	V
Output Current (Note 1)	I_{OUT}	$V_{IN}=V_{OUT}+2V$	70	100		mA
Dropout Voltage (Note 2)	V_{DROP}	$I_{OUT}=1\text{mA}$		40	100	mV
Line Regulation	$\frac{\Delta V_{OUT1}}{\Delta V_{IN} \cdot V_{OUT}}$	$V_{OUT}+2V \leq V_{IN} \leq 36V, I_{OUT}=1\text{mA}$		0.05	0.2	%/V
Load Regulation	ΔV_{OUT2}	$V_{IN}=V_{OUT}+2V, 1.0\text{mA} \leq I_{OUT} \leq 50\text{mA}$		30	80	mV
Output Voltage Temperature Coefficient	$\frac{\Delta V_{OUT1}}{T_A \cdot V_{OUT}}$	$V_{IN}=V_{OUT}+2V, I_{OUT}=10\text{mA}, -40^\circ\text{C} \leq T_A \leq 85^\circ\text{C}$		±50	±100	Ppm/°C
Supply Current	I_{SS1}	$V_{IN}=V_{OUT}+2V$		1.2	3.0	uA

■ ELECTRICAL CHARACTERISTICS (Cont.)

UTC UR7523

PARAMETER	SYMBOL	TEST CONDITIONS	MIN	TYP	MAX	UNIT
Output Voltage	V_{OUT}	$V_{IN}=V_{OUT}+2V, I_{OUT}=10mA$	2.254	2.3	2.346	V
Output Current (Note 1)	I_{OUT}	$V_{IN}=V_{OUT}+2V$	70	100		mA
Dropout Voltage (Note 2)	V_{DROP}	$I_{OUT}=1mA$		40	100	mV
Line Regulation	$\frac{\Delta V_{OUT1}}{\Delta V_{IN} \cdot V_{OUT}}$	$V_{OUT}+2V \leq V_{IN} \leq 36V, I_{OUT}=1mA$		0.05	0.2	%/V
Load Regulation	ΔV_{OUT2}	$V_{IN}=V_{OUT}+2V, 1.0mA \leq I_{OUT} \leq 50mA$		30	80	mV
Output Voltage Temperature Coefficient	$\frac{\Delta V_{OUT1}}{T_A \cdot V_{OUT}}$	$V_{IN}=V_{OUT}+2V, I_{OUT}=10mA, -40^\circ C \leq T_A \leq 85^\circ C$		± 50	± 100	Ppm/ $^\circ C$
Supply Current	I_{SS1}	$V_{IN}=V_{OUT}+2V$		1.2	3.0	μA

UTC UR7525

PARAMETER	SYMBOL	TEST CONDITIONS	MIN	TYP	MAX	UNIT
Output Voltage	V_{OUT}	$V_{IN}=V_{OUT}+2V, I_{OUT}=10mA$	2.45	2.5	2.55	V
Output Current (Note 1)	I_{OUT}	$V_{IN}=V_{OUT}+2V$	70	100		mA
Dropout Voltage (Note 2)	V_{DROP}	$I_{OUT}=1mA$		40	100	mV
Line Regulation	$\frac{\Delta V_{OUT1}}{\Delta V_{IN} \cdot V_{OUT}}$	$V_{OUT}+2V \leq V_{IN} \leq 36V, I_{OUT}=1mA$		0.05	0.2	%/V
Load Regulation	ΔV_{OUT2}	$V_{IN}=V_{OUT}+2V, 1.0mA \leq I_{OUT} \leq 50mA$		30	80	mV
Output Voltage Temperature Coefficient	$\frac{\Delta V_{OUT1}}{T_A \cdot V_{OUT}}$	$V_{IN}=V_{OUT}+2V, I_{OUT}=10mA, -40^\circ C \leq T_A \leq 85^\circ C$		± 50	± 100	Ppm/ $^\circ C$
Supply Current	I_{SS1}	$V_{IN}=V_{OUT}+2V$		1.2	3.0	μA

UTC UR7527

PARAMETER	SYMBOL	TEST CONDITIONS	MIN	TYP	MAX	UNIT
Output Voltage	V_{OUT}	$V_{IN}=V_{OUT}+2V, I_{OUT}=10mA$	2.646	2.7	2.754	V
Output Current (Note 1)	I_{OUT}	$V_{IN}=V_{OUT}+2V$	70	100		mA
Dropout Voltage (Note 2)	V_{DROP}	$I_{OUT}=1mA$		40	100	mV
Line Regulation	$\frac{\Delta V_{OUT1}}{\Delta V_{IN} \cdot V_{OUT}}$	$V_{OUT}+2V \leq V_{IN} \leq 36V, I_{OUT}=1mA$		0.05	0.2	%/V
Load Regulation	ΔV_{OUT2}	$V_{IN}=V_{OUT}+2V, 1.0mA \leq I_{OUT} \leq 50mA$		30	80	mV
Output Voltage Temperature Coefficient	$\frac{\Delta V_{OUT1}}{T_A \cdot V_{OUT}}$	$V_{IN}=V_{OUT}+2V, I_{OUT}=10mA, -40^\circ C \leq T_A \leq 85^\circ C$		± 50	± 100	Ppm/ $^\circ C$
Supply Current	I_{SS1}	$V_{IN}=V_{OUT}+2V$		1.2	3.0	μA

UTC UR7530

PARAMETER	SYMBOL	TEST CONDITIONS	MIN	TYP	MAX	UNIT
Output Voltage	V_{OUT}	$V_{IN}=V_{OUT}+2V, I_{OUT}=10mA$	2.94	3.0	3.06	V
Output Current (Note 1)	I_{OUT}	$V_{IN}=V_{OUT}+2V$	70	100		mA
Dropout Voltage (Note 2)	V_{DROP}	$I_{OUT}=1mA$		40	100	mV
Line Regulation	$\frac{\Delta V_{OUT1}}{\Delta V_{IN} \cdot V_{OUT}}$	$V_{OUT}+2V \leq V_{IN} \leq 36V, I_{OUT}=1mA$		0.05	0.2	%/V
Load Regulation	ΔV_{OUT2}	$V_{IN}=V_{OUT}+2V, 1.0mA \leq I_{OUT} \leq 50mA$		30	80	mV
Output Voltage Temperature Coefficient	$\frac{\Delta V_{OUT1}}{T_A \cdot V_{OUT}}$	$V_{IN}=V_{OUT}+2V, I_{OUT}=10mA, -40^\circ C \leq T_A \leq 85^\circ C$		± 50	± 100	Ppm/ $^\circ C$
Supply Current	I_{SS1}	$V_{IN}=V_{OUT}+2V$		1.2	3.0	μA

■ ELECTRICAL CHARACTERISTICS (Cont.)

UTC UR7533

PARAMETER	SYMBOL	TEST CONDITIONS	MIN	TYP	MAX	UNIT
Output Voltage	V_{OUT}	$V_{IN}=V_{OUT}+2V, I_{OUT}=10mA$	3.234	3.3	3.366	V
Output Current (Note 1)	I_{OUT}	$V_{IN}=V_{OUT}+2V$	100	150		mA
Dropout Voltage (Note 2)	V_{DROP}	$I_{OUT}=1mA$		30	80	mV
Line Regulation	$\frac{\Delta V_{OUT1}}{\Delta V_{IN} \cdot V_{OUT}}$	$V_{OUT}+2V \leq V_{IN} \leq 36V, I_{OUT}=1mA$		0.05	0.2	%/V
Load Regulation	ΔV_{OUT2}	$V_{IN}=V_{OUT}+2V, 1.0mA \leq I_{OUT} \leq 50mA$		30	80	mV
Output Voltage Temperature Coefficient	$\frac{\Delta V_{OUT1}}{T_A \cdot V_{OUT}}$	$V_{IN}=V_{OUT}+2V, I_{OUT}=10mA, -40^\circ C \leq T_A \leq 85^\circ C$		± 50	± 100	Ppm/ $^\circ C$
Supply Current	I_{SS1}	$V_{IN}=V_{OUT}+2V$		1.2	3.0	μA

UTC UR7536

PARAMETER	SYMBOL	TEST CONDITIONS	MIN	TYP	MAX	UNIT
Output Voltage	V_{OUT}	$V_{IN}=V_{OUT}+2V, I_{OUT}=10mA$	3.528	3.6	3.672	V
Output Current (Note 1)	I_{OUT}	$V_{IN}=V_{OUT}+2V$	100	150		mA
Dropout Voltage (Note 2)	V_{DROP}	$I_{OUT}=1mA$		30	65	mV
Line Regulation	$\frac{\Delta V_{OUT1}}{\Delta V_{IN} \cdot V_{OUT}}$	$V_{OUT}+2V \leq V_{IN} \leq 36V, I_{OUT}=1mA$		0.05	0.2	%/V
Load Regulation	ΔV_{OUT2}	$V_{IN}=V_{OUT}+2V, 1.0mA \leq I_{OUT} \leq 50mA$		30	80	mV
Output Voltage Temperature Coefficient	$\frac{\Delta V_{OUT1}}{T_A \cdot V_{OUT}}$	$V_{IN}=V_{OUT}+2V, I_{OUT}=10mA, -40^\circ C \leq T_A \leq 85^\circ C$		± 50	± 100	Ppm/ $^\circ C$
Supply Current	I_{SS1}	$V_{IN}=V_{OUT}+2V$		1.2	3.0	μA

UTC UR7540

PARAMETER	SYMBOL	TEST CONDITIONS	MIN	TYP	MAX	UNIT
Output Voltage	V_{OUT}	$V_{IN}=V_{OUT}+2V, I_{OUT}=10mA$	3.92	4.0	4.08	V
Output Current (Note 1)	I_{OUT}	$V_{IN}=V_{OUT}+2V$	100	150		mA
Dropout Voltage (Note 2)	V_{DROP}	$I_{OUT}=1mA$		30	65	mV
Line Regulation	$\frac{\Delta V_{OUT1}}{\Delta V_{IN} \cdot V_{OUT}}$	$V_{OUT}+2V \leq V_{IN} \leq 36V, I_{OUT}=1mA$		0.05	0.2	%/V
Load Regulation	ΔV_{OUT2}	$V_{IN}=V_{OUT}+2V, 1.0mA \leq I_{OUT} \leq 50mA$		30	80	mV
Output Voltage Temperature Coefficient	$\frac{\Delta V_{OUT1}}{T_A \cdot V_{OUT}}$	$V_{IN}=V_{OUT}+2V, I_{OUT}=10mA, -40^\circ C \leq T_A \leq 85^\circ C$		± 50	± 100	Ppm/ $^\circ C$
Supply Current	I_{SS1}	$V_{IN}=V_{OUT}+2V$		1.2	3.0	μA

UTC UR7544

PARAMETER	SYMBOL	TEST CONDITIONS	MIN	TYP	MAX	UNIT
Output Voltage	V_{OUT}	$V_{IN}=V_{OUT}+2V, I_{OUT}=10mA$	4.312	4.4	4.488	V
Output Current (Note 1)	I_{OUT}	$V_{IN}=V_{OUT}+2V$	100	150		mA
Dropout Voltage (Note 2)	V_{DROP}	$I_{OUT}=1mA$		30	65	mV
Line Regulation	$\frac{\Delta V_{OUT1}}{\Delta V_{IN} \cdot V_{OUT}}$	$V_{OUT}+2V \leq V_{IN} \leq 36V, I_{OUT}=1mA$		0.05	0.2	%/V
Load Regulation	ΔV_{OUT2}	$V_{IN}=V_{OUT}+2V, 1.0mA \leq I_{OUT} \leq 50mA$		30	80	mV
Output Voltage Temperature Coefficient	$\frac{\Delta V_{OUT1}}{T_A \cdot V_{OUT}}$	$V_{IN}=V_{OUT}+2V, I_{OUT}=10mA, -40^\circ C \leq T_A \leq 85^\circ C$		± 50	± 100	Ppm/ $^\circ C$
Supply Current	I_{SS1}	$V_{IN}=V_{OUT}+2V$		1.2	3.0	μA

■ ELECTRICAL CHARACTERISTICS (Cont.)

UTC UR7550

PARAMETER	SYMBOL	TEST CONDITIONS	MIN	TYP	MAX	UNIT
Output Voltage	V_{OUT}	$V_{IN}=V_{OUT}+2V, I_{OUT}=10mA$	4.9	5.0	5.1	V
Output Current (Note 1)	I_{OUT}	$V_{IN}=V_{OUT}+2V$	100	150		mA
Dropout Voltage (Note 2)	V_{DROP}	$I_{OUT}=1mA$		30	65	mV
Line Regulation	$\frac{\Delta V_{OUT1}}{\Delta V_{IN} \cdot V_{OUT}}$	$V_{OUT}+2V \leq V_{IN} \leq 36V, I_{OUT}=1mA$		0.05	0.2	%/V
Load Regulation	ΔV_{OUT2}	$V_{IN}=V_{OUT}+2V, 1.0mA \leq I_{OUT} \leq 50mA$		30	80	mV
Output Voltage Temperature Coefficient	$\frac{\Delta V_{OUT1}}{T_A \cdot V_{OUT}}$	$V_{IN}=V_{OUT}+2V, I_{OUT}=10mA, -40^\circ C \leq T_A \leq 85^\circ C$		± 50	± 100	Ppm/ $^\circ C$
Supply Current	I_{SS1}	$V_{IN}=V_{OUT}+2V$		1.2	3.0	μA

UTC UR7560

PARAMETER	SYMBOL	TEST CONDITIONS	MIN	TYP	MAX	UNIT
Output Voltage	V_{OUT}	$V_{IN}=V_{OUT}+2V, I_{OUT}=10mA$	5.88	6.0	6.12	V
Output Current (Note 1)	I_{OUT}	$V_{IN}=V_{OUT}+2V$	100	150		mA
Dropout Voltage (Note 2)	V_{DROP}	$I_{OUT}=1mA$		30	60	mV
Line Regulation	$\frac{\Delta V_{OUT1}}{\Delta V_{IN} \cdot V_{OUT}}$	$V_{OUT}+2V \leq V_{IN} \leq 36V, I_{OUT}=1mA$		0.05	0.2	%/V
Load Regulation	ΔV_{OUT2}	$V_{IN}=V_{OUT}+2V, 1.0mA \leq I_{OUT} \leq 50mA$		30	80	mV
Output Voltage Temperature Coefficient	$\frac{\Delta V_{OUT1}}{T_A \cdot V_{OUT}}$	$V_{IN}=V_{OUT}+2V, I_{OUT}=10mA, -40^\circ C \leq T_A \leq 85^\circ C$		± 50	± 100	Ppm/ $^\circ C$
Supply Current	I_{SS1}	$V_{IN}=V_{OUT}+2V$		1.2	3.0	μA

UTC UR7570

PARAMETER	SYMBOL	TEST CONDITIONS	MIN	TYP	MAX	UNIT
Output Voltage	V_{OUT}	$V_{IN}=V_{OUT}+2V, I_{OUT}=10mA$	6.86	7.0	7.14	V
Output Current (Note 1)	I_{OUT}	$V_{IN}=V_{OUT}+2V$	100	150		mA
Dropout Voltage (Note 2)	V_{DROP}	$I_{OUT}=1mA$		30	60	mV
Line Regulation	$\frac{\Delta V_{OUT1}}{\Delta V_{IN} \cdot V_{OUT}}$	$V_{OUT}+2V \leq V_{IN} \leq 36V, I_{OUT}=1mA$		0.05	0.2	%/V
Load Regulation	ΔV_{OUT2}	$V_{IN}=V_{OUT}+2V, 1.0mA \leq I_{OUT} \leq 50mA$		30	80	mV
Output Voltage Temperature Coefficient	$\frac{\Delta V_{OUT1}}{T_A \cdot V_{OUT}}$	$V_{IN}=V_{OUT}+2V, I_{OUT}=10mA, -40^\circ C \leq T_A \leq 85^\circ C$		± 50	± 100	Ppm/ $^\circ C$
Supply Current	I_{SS1}	$V_{IN}=V_{OUT}+2V$		1.2	3.0	μA

UTC UR7580

PARAMETER	SYMBOL	TEST CONDITIONS	MIN	TYP	MAX	UNIT
Output Voltage	V_{OUT}	$V_{IN}=V_{OUT}+2V, I_{OUT}=10mA$	7.84	8.0	8.16	V
Output Current (Note 1)	I_{OUT}	$V_{IN}=V_{OUT}+2V$	100	150		mA
Dropout Voltage (Note 2)	V_{DROP}	$I_{OUT}=1mA$		30	60	mV
Line Regulation	$\frac{\Delta V_{OUT1}}{\Delta V_{IN} \cdot V_{OUT}}$	$V_{OUT}+2V \leq V_{IN} \leq 36V, I_{OUT}=1mA$		0.05	0.2	%/V
Load Regulation	ΔV_{OUT2}	$V_{IN}=V_{OUT}+2V, 1.0mA \leq I_{OUT} \leq 50mA$		30	80	mV
Output Voltage Temperature Coefficient	$\frac{\Delta V_{OUT1}}{T_A \cdot V_{OUT}}$	$V_{IN}=V_{OUT}+2V, I_{OUT}=10mA, -40^\circ C \leq T_A \leq 85^\circ C$		± 50	± 100	Ppm/ $^\circ C$
Supply Current	I_{SS1}	$V_{IN}=V_{OUT}+2V$		1.2	3.0	μA

■ ELECTRICAL CHARACTERISTICS (Cont.)

UTC UR7590

PARAMETER	SYMBOL	TEST CONDITIONS	MIN	TYP	MAX	UNIT
Output Voltage	V_{OUT}	$V_{IN}=V_{OUT}+2V, I_{OUT}=10mA$	8.82	9.0	9.18	V
Output Current (Note 1)	I_{OUT}	$V_{IN}=V_{OUT}+2V$	100	150		mA
Dropout Voltage (Note 2)	V_{DROP}	$I_{OUT}=1mA$		25	55	mV
Line Regulation	$\frac{\Delta V_{OUT1}}{\Delta V_{IN} \cdot V_{OUT}}$	$V_{OUT}+2V \leq V_{IN} \leq 36V, I_{OUT}=1mA$		0.05	0.2	%/V
Load Regulation	ΔV_{OUT2}	$V_{IN}=V_{OUT}+2V, 1.0mA \leq I_{OUT} \leq 50mA$		30	80	mV
Output Voltage Temperature Coefficient	$\frac{\Delta V_{OUT1}}{T_A \cdot V_{OUT}}$	$V_{IN}=V_{OUT}+2V, I_{OUT}=10mA, -40^\circ C \leq T_A \leq 85^\circ C$		± 50	± 100	Ppm/ $^\circ C$
Supply Current	I_{SS1}	$V_{IN}=V_{OUT}+2V$		1.2	3.0	μA

UTC UR7510

PARAMETER	SYMBOL	TEST CONDITIONS	MIN	TYP	MAX	UNIT
Output Voltage	V_{OUT}	$V_{IN}=V_{OUT}+2V, I_{OUT}=10mA$	9.8	10.0	10.2	V
Output Current (Note 1)	I_{OUT}	$V_{IN}=V_{OUT}+2V$	100	150		mA
Dropout Voltage (Note 2)	V_{DROP}	$I_{OUT}=1mA$		25	55	mV
Line Regulation	$\frac{\Delta V_{OUT1}}{\Delta V_{IN} \cdot V_{OUT}}$	$V_{OUT}+2V \leq V_{IN} \leq 36V, I_{OUT}=1mA$		0.05	0.2	%/V
Load Regulation	ΔV_{OUT2}	$V_{IN}=V_{OUT}+2V, 1.0mA \leq I_{OUT} \leq 50mA$		30	80	mV
Output Voltage Temperature Coefficient	$\frac{\Delta V_{OUT1}}{T_A \cdot V_{OUT}}$	$V_{IN}=V_{OUT}+2V, I_{OUT}=10mA, -40^\circ C \leq T_A \leq 85^\circ C$		± 50	± 100	Ppm/ $^\circ C$
Supply Current	I_{SS1}	$V_{IN}=V_{OUT}+2V$		1.2	3.0	μA

UTC UR7512

PARAMETER	SYMBOL	TEST CONDITIONS	MIN	TYP	MAX	UNIT
Output Voltage	V_{OUT}	$V_{IN}=V_{OUT}+2V, I_{OUT}=10mA$	11.76	12.0	12.24	V
Output Current (Note 1)	I_{OUT}	$V_{IN}=V_{OUT}+2V$	100	150		mA
Dropout Voltage (Note 2)	V_{DROP}	$I_{OUT}=1mA$		25	55	mV
Line Regulation	$\frac{\Delta V_{OUT1}}{\Delta V_{IN} \cdot V_{OUT}}$	$V_{OUT}+2V \leq V_{IN} \leq 36V, I_{OUT}=1mA$		0.05	0.2	%/V
Load Regulation	ΔV_{OUT2}	$V_{IN}=V_{OUT}+2V, 1.0mA \leq I_{OUT} \leq 50mA$		30	80	mV
Output Voltage Temperature Coefficient	$\frac{\Delta V_{OUT1}}{T_A \cdot V_{OUT}}$	$V_{IN}=V_{OUT}+2V, I_{OUT}=10mA, -40^\circ C \leq T_A \leq 85^\circ C$		± 50	± 100	Ppm/ $^\circ C$
Supply Current	I_{SS1}	$V_{IN}=V_{OUT}+2V$		1.2	3.0	μA

Notes: 1. Increase the output current slowly, record the current when V_{OUT} decrease 98% of V_{OUT} .

2. $V_{drop}=V_{IN1}-(V_{OUT} \times 0.98)$, $V_{OUT}: V_{IN}=V_{OUT}+2V, I_{OUT}=1mA$

■ TEST CIRCUIT

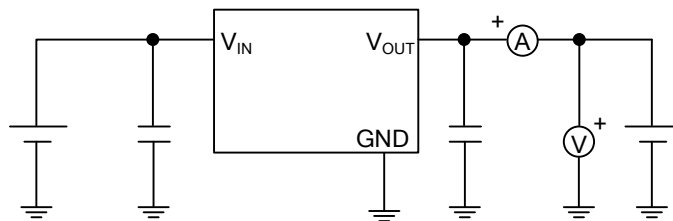
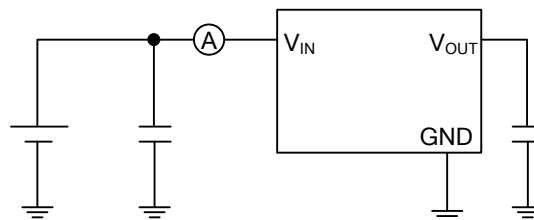
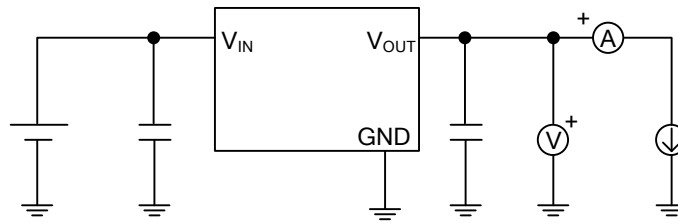

■ TYPICAL APPLICATION CIRCUIT

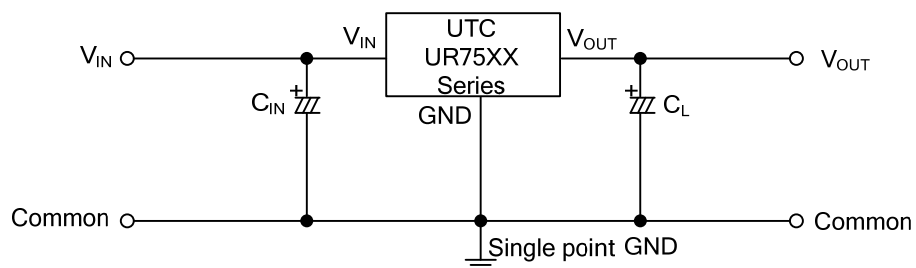

$C_{IN} > 1.0\mu\text{F}$
 $C_L > 2.2\mu\text{F}$ (tantalum capacitor)

■ TYPICAL CHARACTERISTICS

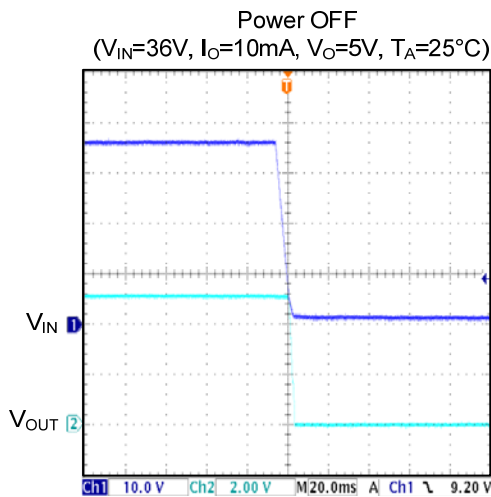
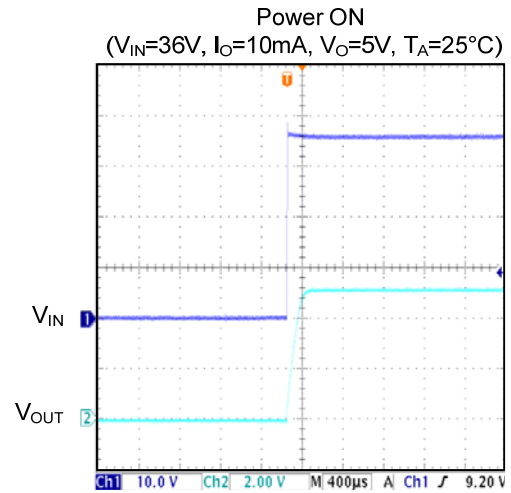
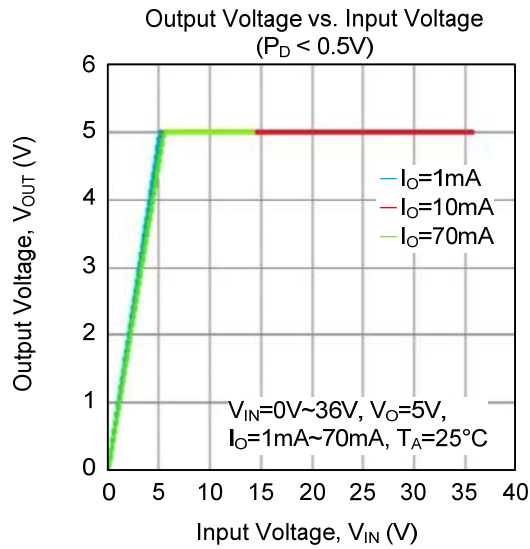

UTC assumes no responsibility for equipment failures that result from using products at values that exceed, even momentarily, rated values (such as maximum ratings, operating condition ranges, or other parameters) listed in products specifications of any and all UTC products described or contained herein. UTC products are not designed for use in life support appliances, devices or systems where malfunction of these products can be reasonably expected to result in personal injury. Reproduction in whole or in part is prohibited without the prior written consent of the copyright owner. UTC reserves the right to make changes to information published in this document, including without limitation specifications and product descriptions, at any time and without notice. This document supersedes and replaces all information supplied prior to the publication hereof.