



UF2768

CMOS IC

THREE-PHASE SINE-WAVE SENSOR-LESS FAN MOTOR DRIVER

DESCRIPTION

The **UF2768** provides all the circuitry for sensor-less speed control of three-phase brushless DC motor. The Sine-wave Driver Method will be better low-noise. The controller functions include start-up circuit, back-EMF commutation control, Pulse Width Modulation (PWM) speed control, lock protection, and thermal shutdown circuit.

The **UF2768** is suitable for both game machine and CPU cooler that need silent drivers.

FEATURES

- * Three-Phase class sin wave driver method
- * Three-Phase Full-Wave Sensor-Less Drive Method
- * Adjustable Forced Commutation Frequency (for Start-up)
- * Built-In External PWM Speed Control
- * Built-In Quick Start Function
- * FG (Rotation Speed Detection) Output
- * Soft Switching Circuit (for Noise Reducing)
- * Power Saving Function (PWM Duty Input is 0%)
- * Built-In Lock Protection and Auto Restart Function
- * Thermal Shutdown Circuit

ORDERING INFORMATION

Ordering Number		Package	Packing
Lead Free	Halogen Free		
UF2768L-SM2-R	UF2768G-SM2-R	MSOP-10	Tape Reel
UF2768L-K10-3030-R	UF2768G-K10-3030-R	DFN3030-10	Tape Reel

<p>UF2768G-SM2-R</p> <p>(1) Packing Type (2) Package Type (3) Green Package</p>	<p>(1) R: Tape Reel (2) SM2: MSOP-10, K10-3030: DFN3030-10 (3) G: Halogen Free and Lead Free, L: Lead Free</p>
---	--

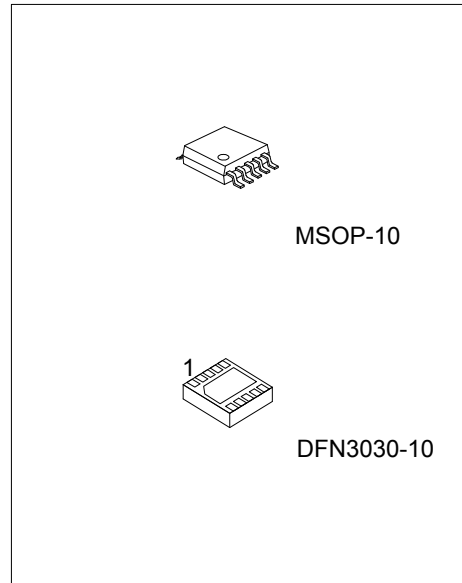

MARKING

MSOP-10	DFN3030-10
<p>UTC □□□□ → Date Code L: Lead Free G: Halogen Free Lot Code</p>	<p>UF 2768 • □□□□ → Date Code</p>

PIN CONFIGURATION

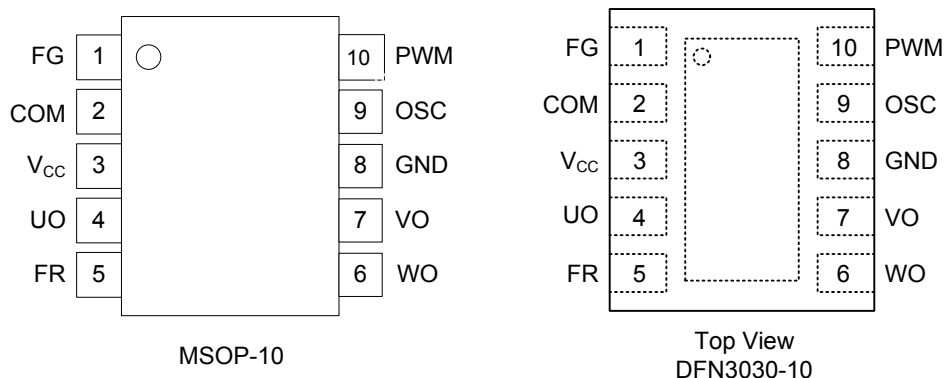

PIN DESCRIPTION

PIN No.	PIN NAME	Description
1	FG	Rotation Speed Output. This is an open-drain output.
2	COM	Motor Neutral Point Input Pin
3	V _{CC}	Supply Voltage Input Pin.
4	UO	Driver Output Pin. Output signal for driving motor phase U.
5	FR	Motor Spin Direction Control Pin. High Level Input: U → V → W Low Level Input: U → W → V
6	WO	Driver Output Pin. Output signal for driving motor phase W.
7	VO	Driver Output Pin. Output signal for driving motor phase V.
8	GND	Ground Pin.
9	OSC	Start-up Commutation Time Setting. Connect a capacitor to GND to set start-up commutation time.
10	PWM	PWM Signal Input Pin. Input PWM signal to control rotation speed.

■ BLOCK DIAGRAM

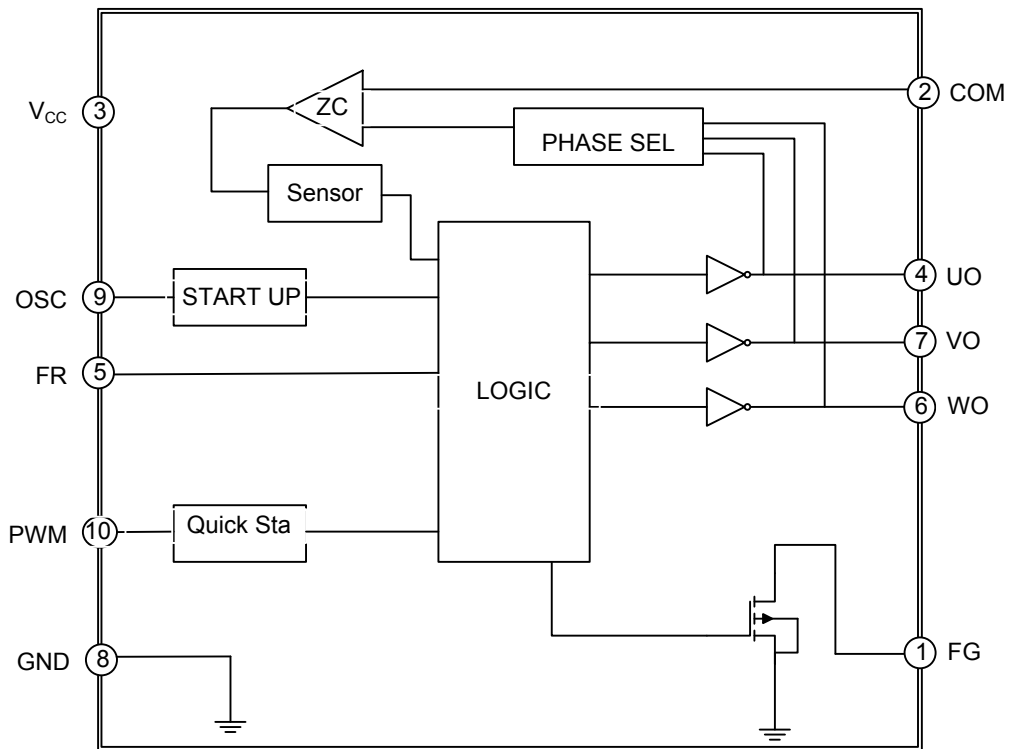

■ ABSOLUTE MAXIMUM RATING

PARAMETER	SYMBOL	RATINGS	UNIT
V _{CC} Pin Supply Voltage	V _{CC}	7	V
UO/VO/WO Pin Output Current	I _{OUT}	1	A
UO/VO/WO Pin Output Voltage	V _{UO} /V _{VO} /V _{WO}	7	V
FG Pin Output Voltage	V _{FG}	7	V
FG Pin Sink Current	I _{FG}	10	mA
FR Pin Input Voltage	V _{FR}	7	V
Power Dissipation	MSOP-10	0.6	W
	DFN3030-10	1.05	W
Junction Temperature	T _J	-40 ~ +150	°C
Storage Temperature	T _{STG}	-65 ~ +150	°C

- Notes: 1. Absolute maximum ratings are those values beyond which the device could be permanently damaged. Absolute maximum ratings are stress ratings only and functional device operation is not implied.
2. Stresses beyond those listed under "absolute maximum ratings" may cause permanent damage to the device. These are stress ratings only and functional operation of the device at these or any other conditions beyond those indicated under "recommended operating conditions" is not implied. Exposure to absolute maximum rating conditions for extended periods may affect device reliability.

■ THERMAL DATA

PARAMETER	SYMBOL	RATINGS	UNIT
Junction to Ambient (Note)	MSOP-10	208	°C/W
	DFN3030-10	119	°C/W

Note: The data tested by surface mounted on a 2 inch² FR-4 board with 2OZ copper.

■ RECOMMENDED OPERATING CONDITIONS

PARAMETER	SYMBOL	RATINGS	UNIT
V _{CC} Pin Supply Voltage Range	V _{CC}	1.8 ~ 6	V
PWM Pin Input Voltage Range	V _{PWM}	0 - V _{CC}	V
UO/VO/WO Pin Average Output Current	I _{OUT}	0 ~ 400	mA
Ambient Temperature	T _A	-40 ~ +105	°C

■ ELECTRICAL CHARACTERISTICS ($V_{CC}=5V$, $T_A=25^{\circ}C$, unless otherwise specified)

PARAMETER	SYMBOL	TEST CONDITIONS	MIN	TYP	MAX	UNIT
SUPPLY CURRENT						
Operating Current	I_{CC1}	Rotation Mode		3.5	5	mA
Standby Supply Current	I_{CC2}	PWM=0		100	150	μA
PWM CONTROL						
PWM Input High Level Voltage	V_{PWMH}			2.5		V
PWM Input Low Level Voltage	V_{PWML}			0.8		V
PWM High Input Current	I_{PWMH}	PWM= V_{CC}		0		μA
PWM Low Input Current	I_{PWML}	PWM=GND		-10	-20	μA
PWM Input Frequency	F_{PWM}		2		50	KHZ
OUTPUT DRIVERS						
Output Driver Saturation Voltage	V_O	$I_{OUT}=250mA$, Upper and Lower total		0.3		V
FG Pin Low Voltage	V_{FG}	$F_G=5mA$		0.2		V
FG Pin Leak Current	I_{FGL}	$V_{FG}=7V$			10	μA
LOCK PROTECTION						
Lock Detection On Time	T_{ON}			1		Sec
Lock Detection Off Time	T_{OFF}			5		Sec
THERMAL SHUTDOWN						
Over Temperature Shutdown	OTS			160		$^{\circ}C$
Over Temperature Shutdown Hysteresis				30		$^{\circ}C$
QUICK START						
Quick Start Enable Time	T_{QS}			16		mS

■ FUNCTIONAL DESCRIPTION

PWM Speed Control (Fixed-Frequency Output)

It is possible to change rotation speed of the motor by switching output transistor. The on-duty of switching de-pends on the signal from input to PWM terminal. The output PWM frequency is fixed frequency.(30KHZ) (See Figure 1 PWM Input Waveform).

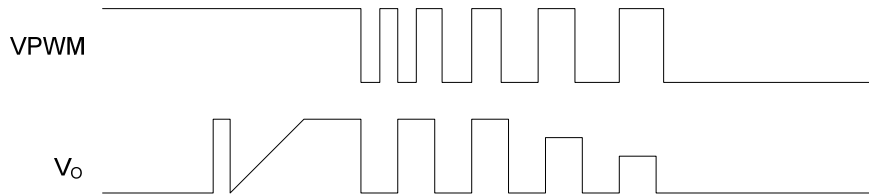

Figure 1. PWM Input Waveform

Quick Start

This IC disables the lock protection function when the PWM input keeps low level for more than 16ms. (See Figure 2 Quick Start Waveform)

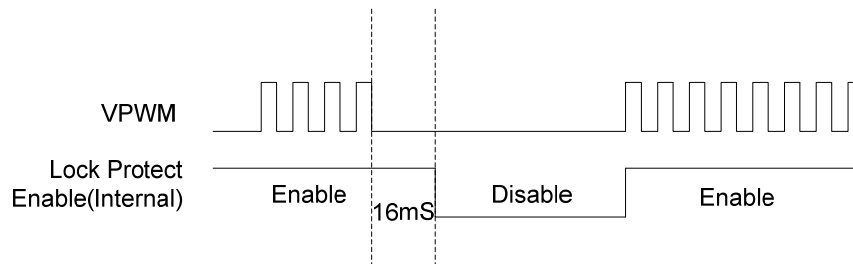

Figure2. Quick Start Waveform

FG Output

The FG pin is an open-drain output, connecting a pull up resistor to a high level voltage for the speed detection function. When WO pin voltage switches to high, the FG is high (switch off) and the WO pin voltage switches to low then FG is low (switch on). The FG output only works in sensor- less mode. (See Figure 3 FG Output Waveform)

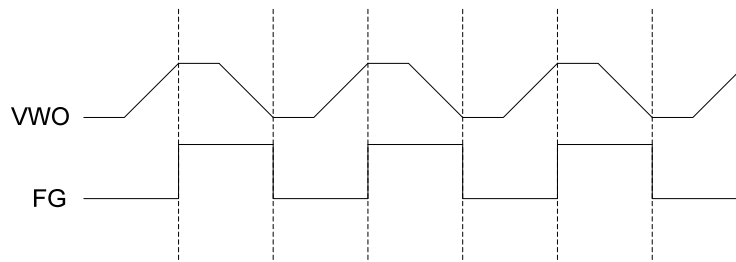

Figure 3. FG Output Waveform

■ FUNCTIONAL DESCRIPTION (Cont.)

Soft Switch (Sine-Wave Output)

The is a soft switch function to make phase current be-come more gentle, which can reduce the noise of motor in switching interval. Using PWM duty cycle control to create the sinusoidal current waveform. BEMF detection window is opened on phase W in order to measure the rotor position so as to define the modulation timing. close to the ideal sine wave output.(See figure 4. Sinusoidal PWM)

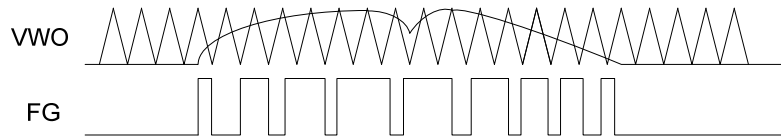

Figure 4. Sinusoidal PWM

Lock Protection and Automatic Restart

The **UF2768** provides the lock protection and automatic restart functions to prevent the coil burnout while the fan is locked. As the fan is locked, the IC will come into startup operation for 1 second. Then, the IC will switch to lock protection mode to close output driver for 6 seconds. After lock protection mode, the IC switches to startup operation again. If the locked condition still remains, the lock and restart process will be recurred until the locked condition is released.

Thermal Protection

The **UF2768** has thermal protection. When internal junction temperature reaches 160°C, the output devices will be switched off. When the IC’s junction temperature cools down 30°C, the thermal sensor will turn on the output devices again, resulting in a pulsed output during continuous thermal protection.

■ APPLICATION INFORMATION

Input Protection Diode & Capacitor

It is necessary to add a protection diode (D1) to prevent the damage from the power reverse connection. However, the protection diode will cause a voltage drop on the supply voltage. The current rating of the diode must be larger than the maximum output current. For the noise reduction purpose, a capacitor (C1) is connected between V_{CC} and GND. (see Typical Application Circuit) It's suggested that C1 should be placed as close as possible in the V_{CC} pin.

OSC Capacitor

The capacitor connects from OSC pin to GND can be determined the frequency of force commutation. The optimal design of the frequency could make sure the motor start-up in succeed. Its capacitance from 1000pF to 3300pF is recommended.

FG Resistor

The value of FG resistor could be decided by the following equation:

$$R_{FG} = \frac{V_{CC} - V_{FG/RD}}{I_{FG/RD}}$$

For example:

$$V_{CC}=5V, I_{FG}=5mA, V_{FG}=0.2V, R_{FG}=0.96k\Omega$$

The value of resistor in the range of 1kw to 10kw is recommended.

Thermal Consideration

Refer to "Maximum Power Dissipation vs. Ambient Temperature", the IC is safe to operate below the curve and it will cause the thermal protection if the operating area is above the line. For example, T_A= 75°C, the MSOP-10 package maximum power dissipation is about 0.48W. The power dissipation can be calculated by the following equation:

$$P_D = (V_{CC} - |V_{UO} - V_{VO}|) \times I_{UO} + V_{CC} \times I_{CC}$$

For example:

$$V_{CC}=5V, I_{CC}=3mA, I_{OUT}=250mA, V_{UO}=4.85V, V_{VO}=0.15V, \text{ then } P_D=0.09W$$

The GND pin provides an electrical connection to the ground and channeling heat away. The printed circuit board (PCB) forms a heat sink and dissipates most of the heat into ambient air.

■ TYPICAL APPLICATION CIRCUIT

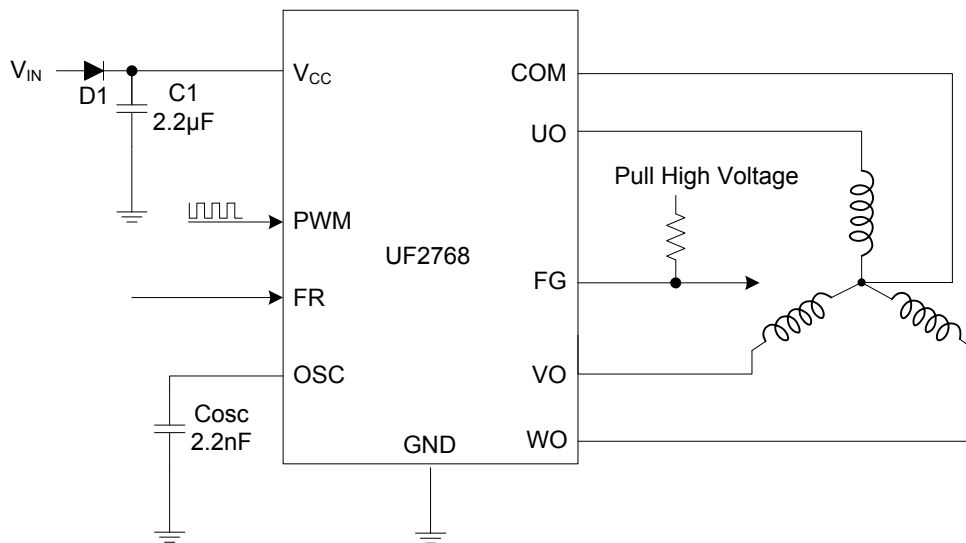

UTC assumes no responsibility for equipment failures that result from using products at values that exceed, even momentarily, rated values (such as maximum ratings, operating condition ranges, or other parameters) listed in products specifications of any and all UTC products described or contained herein. UTC products are not designed for use in life support appliances, devices or systems where malfunction of these products can be reasonably expected to result in personal injury. Reproduction in whole or in part is prohibited without the prior written consent of the copyright owner. UTC reserves the right to make changes to information published in this document, including without limitation specifications and product descriptions, at any time and without notice. This document supersedes and replaces all information supplied prior to the publication hereof.