



3N50-FC

Power MOSFET

3A, 500V N-CHANNEL POWER MOSFET

DESCRIPTION

The UTC **3N50-FC** is a high voltage power MOSFET designed to have better characteristics, such as fast switching time, low gate charge, low on-state resistance and high rugged avalanche characteristics. This power MOSFET is usually used in high speed switching applications of switching power supplies and adaptors.

FEATURES

- * $R_{DS(ON)} \leq 2.6\Omega @ V_{GS}=10V, I_D=1.5A$
- * Fast switching capability
- * Avalanche energy tested
- * Improved dv/dt capability, high ruggedness

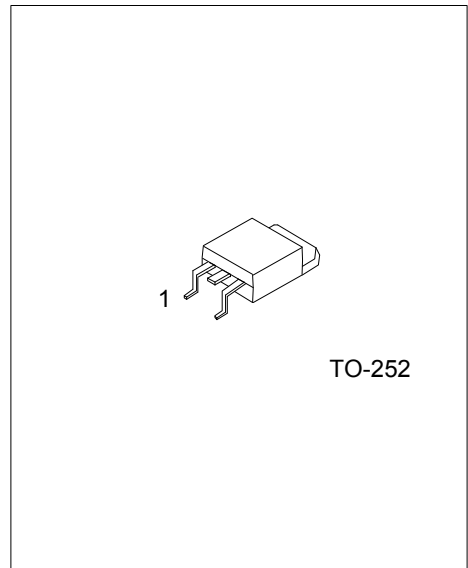

SYMBOL

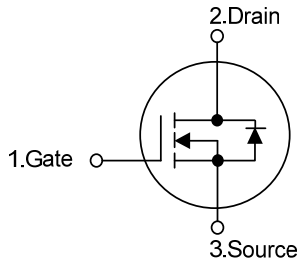

ORDERING INFORMATION

Ordering Number		Package	Pin Assignment			Packing
Lead Free	Halogen Free		1	2	3	
3N50L-TN3-R	3N50G-TN3-R	TO-252	G	D	S	Tape Reel

Note: Pin Assignment: G: Gate D: Drain S: Source

<p>3N50G-TN3-R</p> <ul style="list-style-type: none"> (1)Packing Type (2)Package Type (3)Green Package 	<ul style="list-style-type: none"> (1) R: Tape Reel (2) TN3: TO-252 (3) G: Halogen Free and Lead Free, L: Lead Free
---	--

MARKING

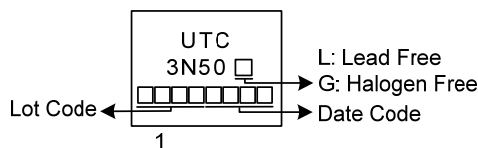

■ ABSOLUTE MAXIMUM RATINGS ($T_C=25^{\circ}\text{C}$, unless otherwise specified)

PARAMETER	SYMBOL	RATINGS	UNIT	
Drain-Source Voltage	V_{DSS}	500	V	
Gate-Source Voltage	V_{GSS}	± 30	V	
Continuous Drain Current	I_D	3	A	
Pulsed Drain Current (Note 2)	I_{DM}	6	A	
Avalanche Energy	Single Pulsed (Note 3)	E_{AS}	140	mJ
Peak Diode Recovery dv/dt (Note 4)	dv/dt	3	V/ns	
Power Dissipation	P_D	45	W	
Junction Temperature	T_J	+150	$^{\circ}\text{C}$	
Storage Temperature	T_{STG}	-55 ~ +150	$^{\circ}\text{C}$	

- Notes: 1. Absolute maximum ratings are those values beyond which the device could be permanently damaged. Absolute maximum ratings are stress ratings only and functional device operation is not implied.
 2. Repetitive Rating: Pulse width limited by maximum junction temperature.
 3. $L = 10\text{mH}$, $I_{AS} = 5.3\text{A}$, $V_{DD} = 50\text{V}$, $R_G = 25\ \Omega$, Starting $T_J = 25^{\circ}\text{C}$
 4. $I_{SD} \leq 3.0\text{A}$, $di/dt \leq 200\text{A}/\mu\text{s}$, $V_{DD} \leq BV_{DSS}$, Starting $T_J = 25^{\circ}\text{C}$

■ THERMAL DATA

PARAMETER	SYMBOL	RATING	UNIT
Junction to Ambient	θ_{JA}	110	$^{\circ}\text{C}/\text{W}$
Junction to Case	θ_{JC}	2.78 (Note)	$^{\circ}\text{C}/\text{W}$

Note: The data tested by surface mounted on a 1 inch² FR-4 board with 2OZ copper.

■ ELECTRICAL CHARACTERISTICS ($T_J=25^{\circ}\text{C}$, unless otherwise specified)

PARAMETER	SYMBOL	TEST CONDITIONS	MIN	TYP	MAX	UNIT	
OFF CHARACTERISTICS							
Drain-Source Breakdown Voltage	BV_{DSS}	$V_{GS}=0\text{V}$, $I_D=250\mu\text{A}$	500			V	
Drain-Source Leakage Current	I_{DSS}	$V_{DS}=500\text{V}$, $V_{GS}=0\text{V}$			10	μA	
Gate- Source Leakage Current	Forward	I_{GSS}			100	nA	
					Reverse	-100	nA
ON CHARACTERISTICS							
Gate Threshold Voltage	$V_{GS(TH)}$	$V_{DS}=V_{GS}$, $I_D=250\mu\text{A}$	2.0		4.0	V	
Static Drain-Source On-State Resistance	$R_{DS(ON)}$	$V_{GS}=10\text{V}$, $I_D=1.5\text{A}$			2.6	Ω	
DYNAMIC CHARACTERISTICS							
Input Capacitance	C_{ISS}	$V_{DS}=25\text{V}$, $V_{GS}=0\text{V}$, $f=1.0\text{MHz}$		300		pF	
Output Capacitance	C_{OSS}				55		pF
Reverse Transfer Capacitance	C_{RSS}				11		pF
SWITCHING CHARACTERISTICS							
Total Gate Charge (Note 1)	Q_G	$V_{DS}=400\text{V}$, $V_{GS}=10\text{V}$, $I_D=3\text{A}$, $I_D=1\text{mA}$ (Note 1, 2)		12.2		nC	
Gate-Source Charge	Q_{GS}				3		nC
Gate-Drain Charge	Q_{GD}				3.6		nC
Turn-On Delay Time (Note 1)	$t_{D(ON)}$	$V_{DD}=100\text{V}$, $V_{GS}=10\text{V}$, $I_D=3\text{A}$, $R_G=25\ \Omega$ (Note 1, 2)		5		ns	
Turn-On Rise Time	t_R				20		ns
Turn-Off Delay Time	$t_{D(OFF)}$				44		ns
Turn-Off Fall Time	t_F				25		ns
DRAIN-SOURCE DIODE CHARACTERISTICS AND MAXIMUM RATINGS							
Maximum Continuous Drain-Source Diode Forward Current	I_S				3	A	
Maximum Pulsed Drain-Source Diode Forward Current	I_{SM}				6	A	
Drain-Source Diode Forward Voltage	V_{SD}	$I_S=3\text{A}$, $V_{GS}=0\text{V}$			1.4	V	
Body Diode Reverse Recovery Time	t_{rr}	$I_S=3\text{A}$, $V_{GS}=0\text{V}$, $di/dt=100\text{A}/\mu\text{s}$		206		ns	
Body Diode Reverse Recovery Charge	Q_{rr}				0.78		μC

Notes: 1. Pulse Test: Pulse width $\leq 300\mu\text{s}$, Duty cycle $\leq 2\%$.
2. Essentially independent of operating temperature.

■ TEST CIRCUITS AND WAVEFORMS

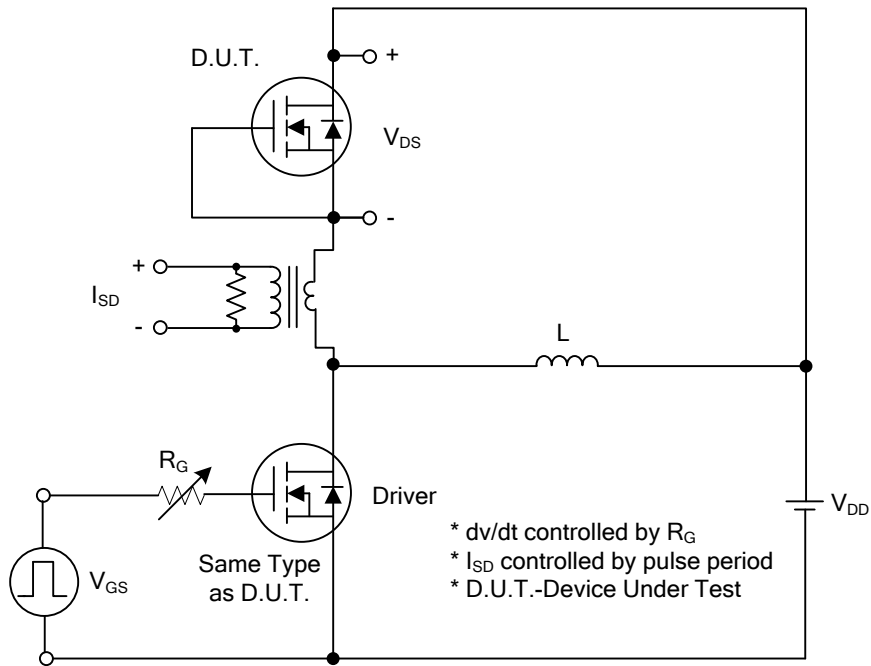

Peak Diode Recovery dv/dt Test Circuit

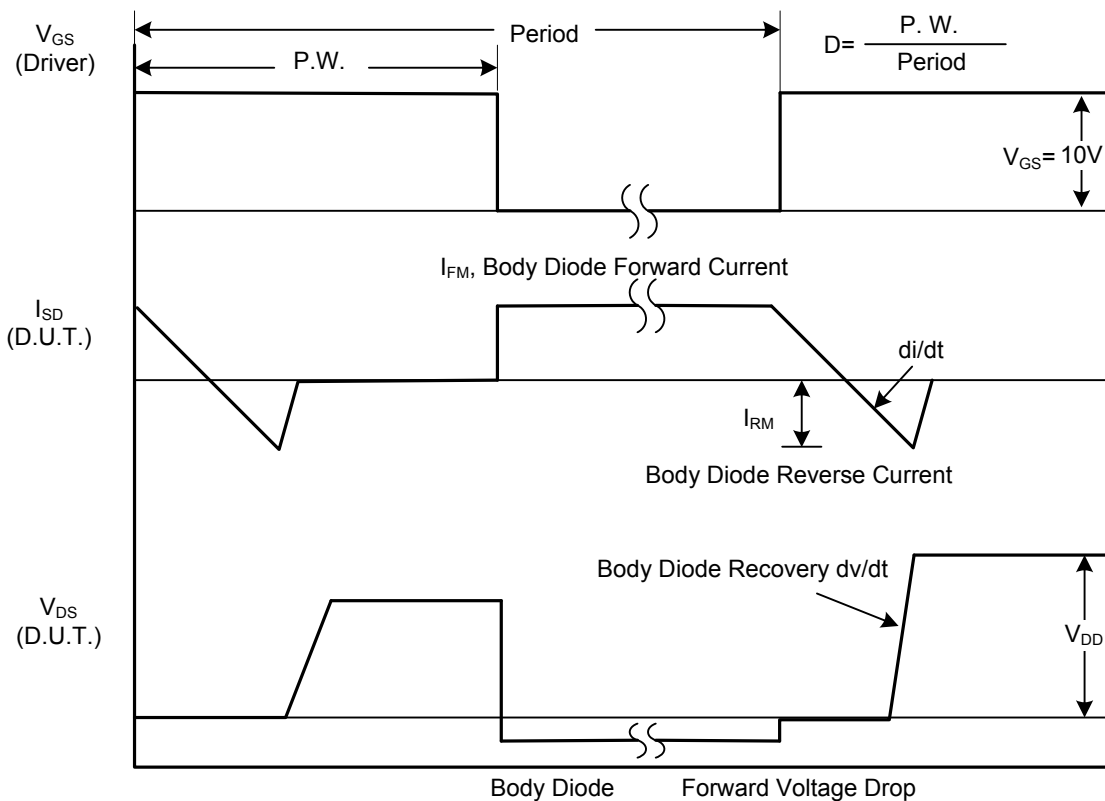

Peak Diode Recovery dv/dt Waveforms

TEST CIRCUITS AND WAVEFORMS

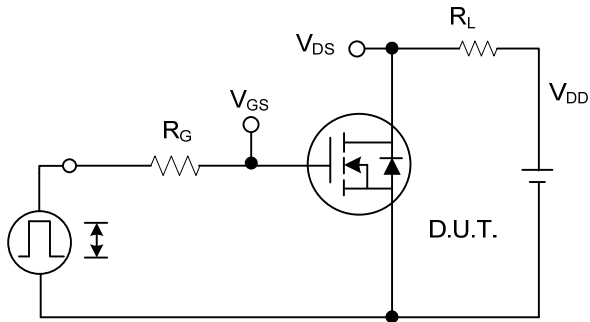

Switching Test Circuit

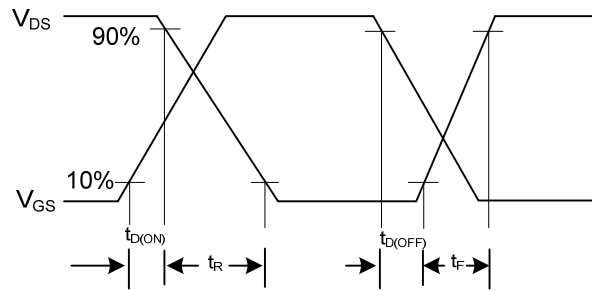

Switching Waveforms

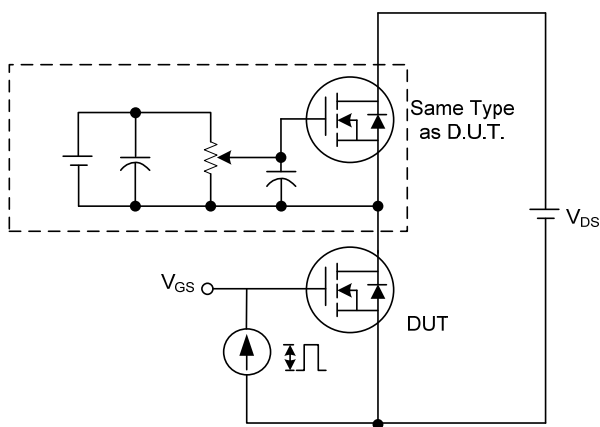

Gate Charge Test Circuit

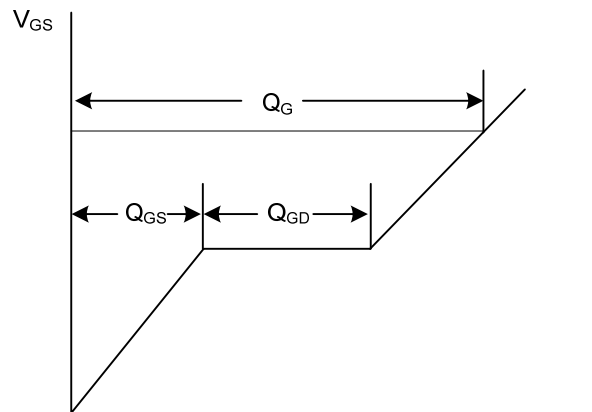

Charge
Gate Charge Waveform

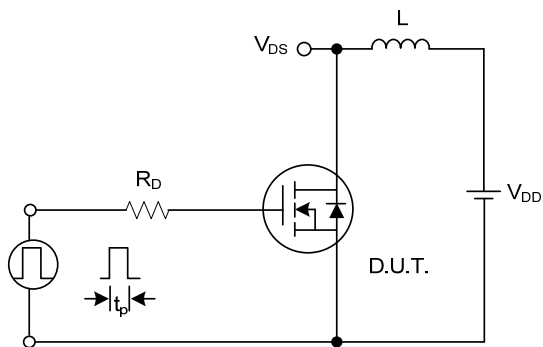

Unclamped Inductive Switching Test Circuit

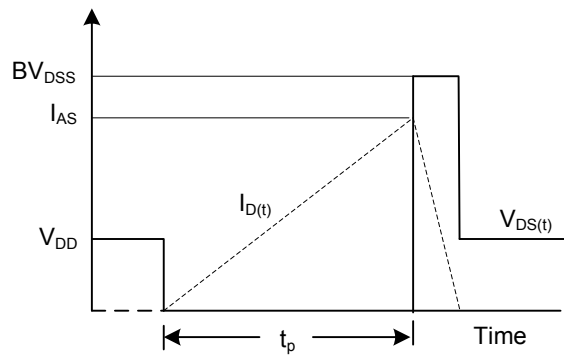

Unclamped Inductive Switching Waveforms

TYPICAL CHARACTERISTICS

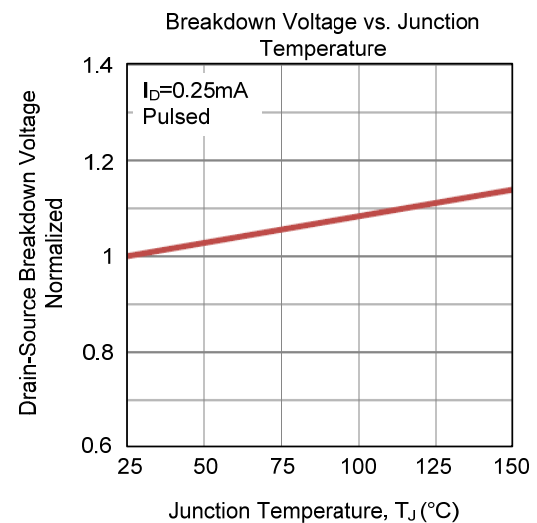
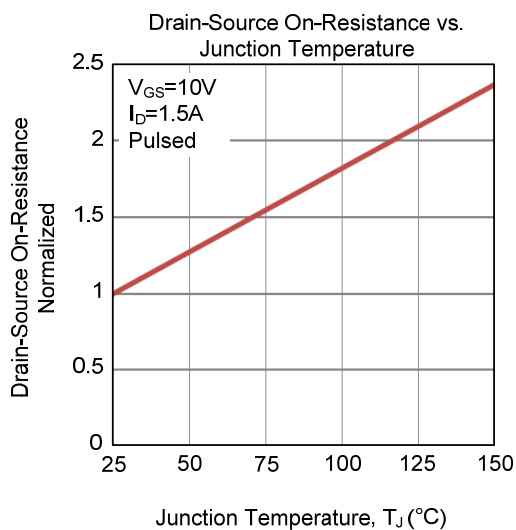
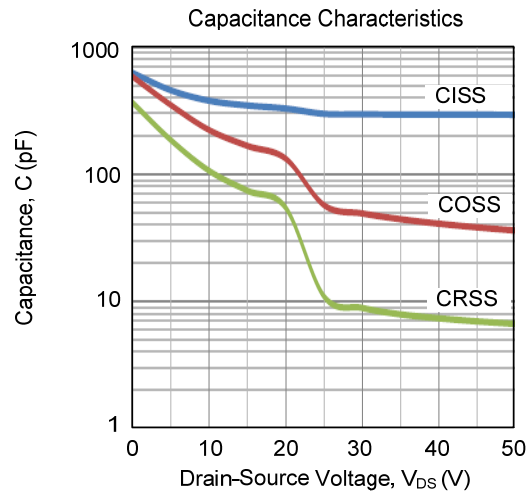
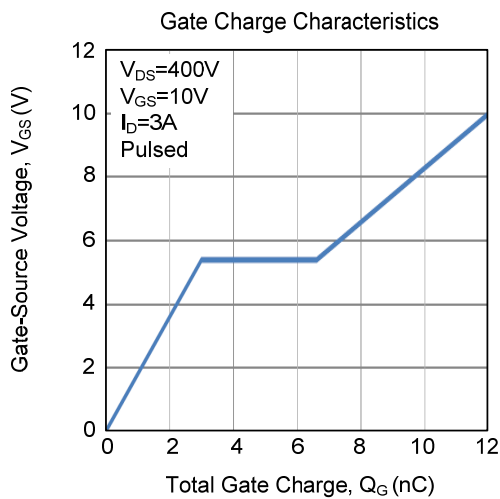
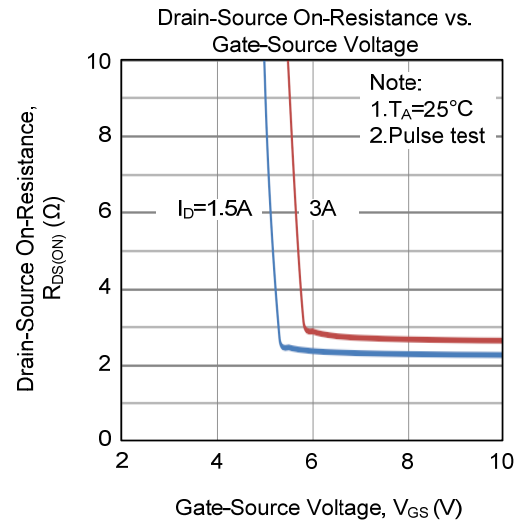
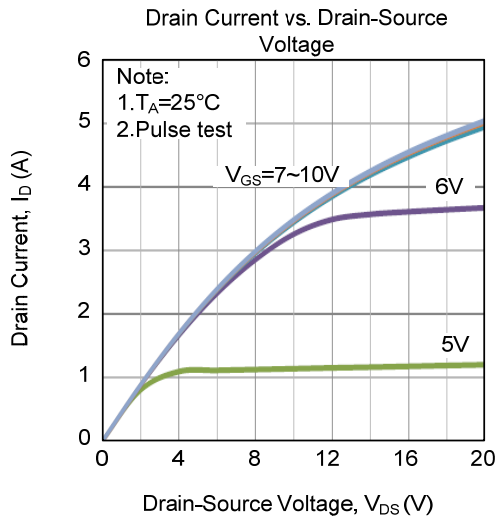

■ TYPICAL CHARACTERISTICS (Cont.)

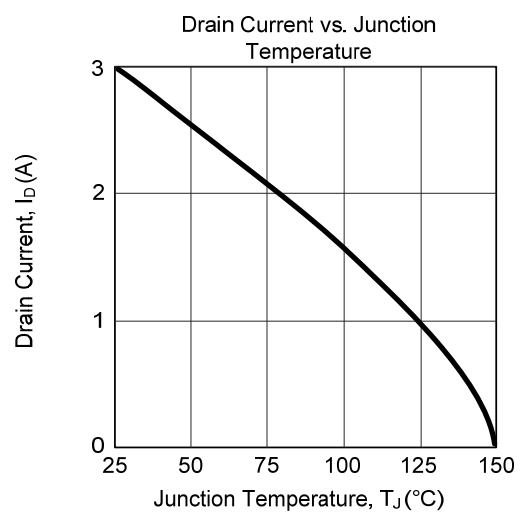
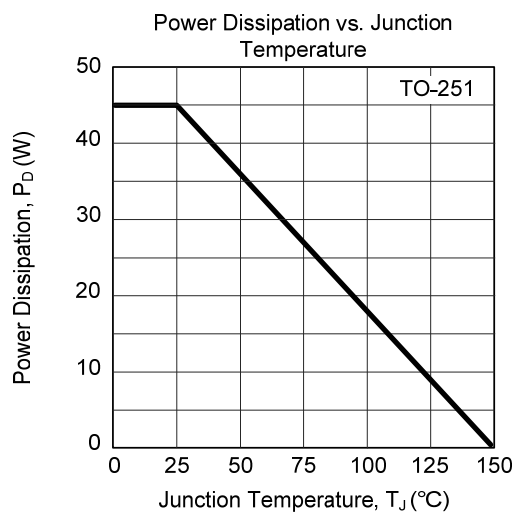
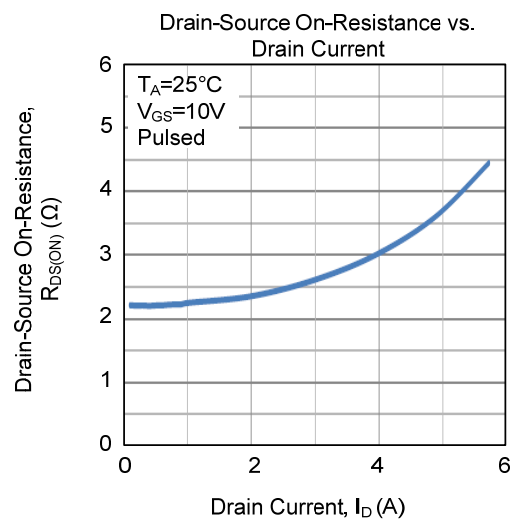
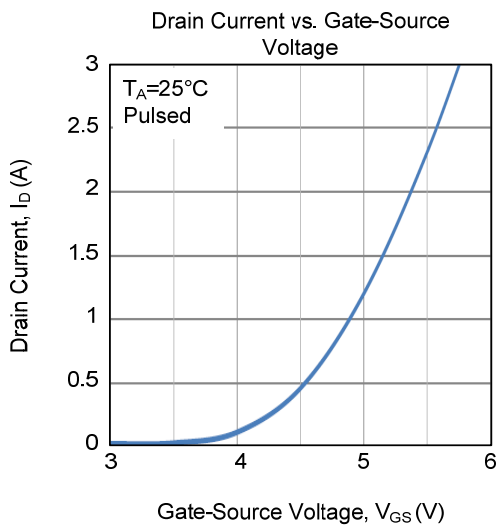
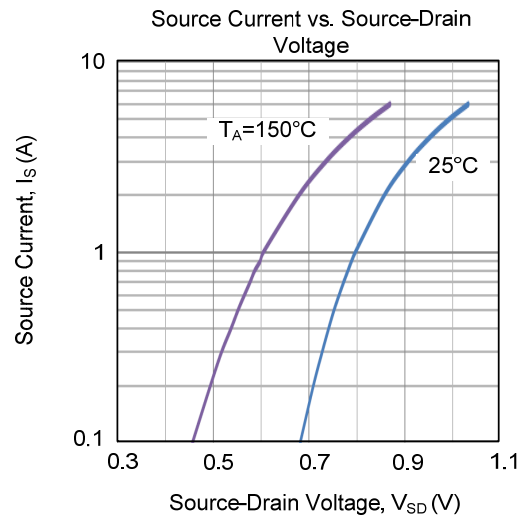
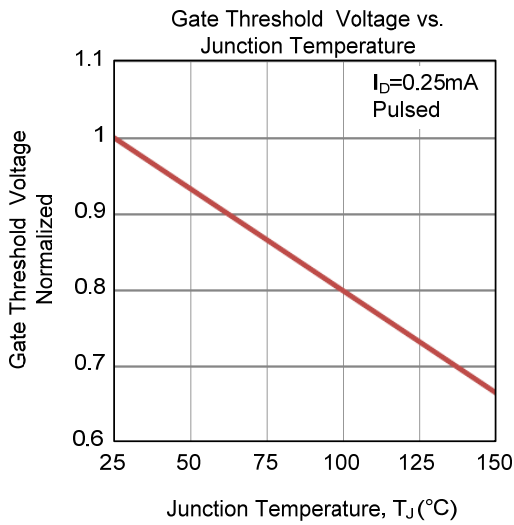

■ TYPICAL CHARACTERISTICS (Cont.)

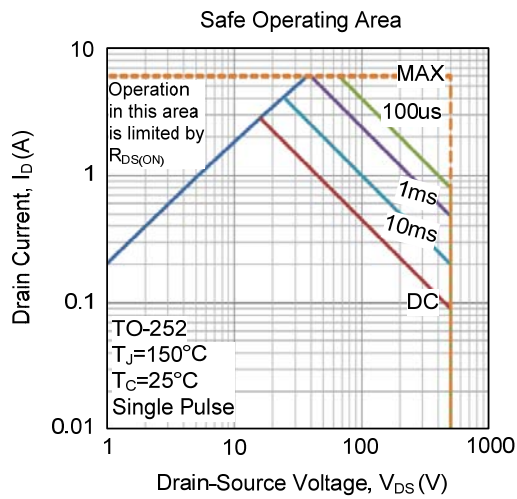

UTC assumes no responsibility for equipment failures that result from using products at values that exceed, even momentarily, rated values (such as maximum ratings, operating condition ranges, or other parameters) listed in products specifications of any and all UTC products described or contained herein. UTC products are not designed for use in life support appliances, devices or systems where malfunction of these products can be reasonably expected to result in personal injury. Reproduction in whole or in part is prohibited without the prior written consent of the copyright owner. UTC reserves the right to make changes to information published in this document, including without limitation specifications and product descriptions, at any time and without notice. This document supersedes and replaces all information supplied prior to the publication hereof.