



## HIGH PERFORMANCE SYNCHRONOUS RECTIFIER

### ■ DESCRIPTION

UTC **USR5V10X** is a high performance and tightly integrated secondary side synchronous rectifier for switch mode power supply system. It combines a much lower voltage drop N-channel MOSFET to emulate the traditional diode rectifier at the secondary side of Flyback converter, which can reduce heat dissipation, increases output current capability and efficiency and simplify thermal design.

It is suitable for multiple mode applications including discontinuous conduction mode and quasi-resonant mode. With its versatility and optimization, UTC **USR5V10X** can be used in various switch mode power supply topologies including secondary-side control topology and primary-side control topology.

From the information on the secondary side of the isolation transformer, UTC **USR5V10X** generates a driving signal with dead time with respect to the primary side PWM signal to turn the integrated N-channel SR switch on and off in proximity of the zero current transition. It is optimized for 5V output voltage. In primary-side control topology, UTC **USR5V10X** can detect the output voltage and feed back a series of warning pulses to primary side controller when the output voltage is lower than an inner-determined threshold to awaken the primary-side power switch to improve dynamic response.

The externally adjustable minimum on time and internally off time control scheme effectively avoid the ring impact induced by parasitic elements so that a reliable and noise free operation of the SR system is insured.

### ■ FEATURES

- \* Low cost small size CC/CV mode support
- \* Accurate secondary side MOSFET  $V_{DS}$  sensing
- \* Secondary-side synchronous rectifier optimized for 5V output system
- \* Output voltage over-shoot control and under-shoot control
- \* Suitable for DCM, QR operation
- \* Up to 150kHz operation frequency
- \*  $V_{DD}$  UVLO protection

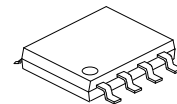

SOP-8

## ORDERING INFORMATION

Ordering Number		Package	Packing
Lead Free	Halogen Free		
USR5V10XL-S08-R	USR5V10XG-S08-R	SOP-8	Tape Reel

<p>USR5V10XG-S08-R</p>	<p>(1) R: Tape Reel                  (2) S08: SOP-8                  (3) G: Halogen Free and Lead Free, L: Lead Free                  (4) Refer to SR MOSFET SECTION</p>
------------------------	--

## MARKING

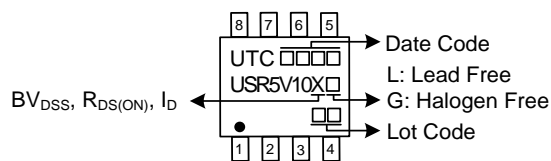

## PIN CONFIGURATION

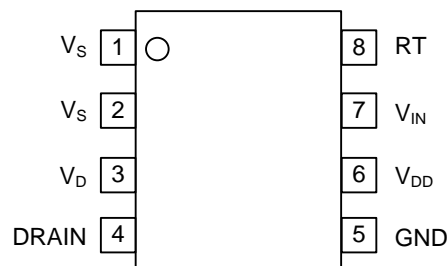

## PIN DESCRIPTION

PIN NO.	PIN NAME	DESCRIPTION
1, 2	$V_s$	This pin is connected to external n-channel MOSFET source
3	$V_D$	This pin is connected to external n-channel MOSFET drain
4	DRAIN	SR MOSFET drain pin. This pin is connected to secondary-side winding of transformer
5	GND	Ground
6	$V_{DD}$	Power Supply
7	$V_{IN}$	System output voltage detection
8	RT	Minimum on time control pin. A resistor is connected from this pin to GND

## ■ BLOCK DIAGRAM

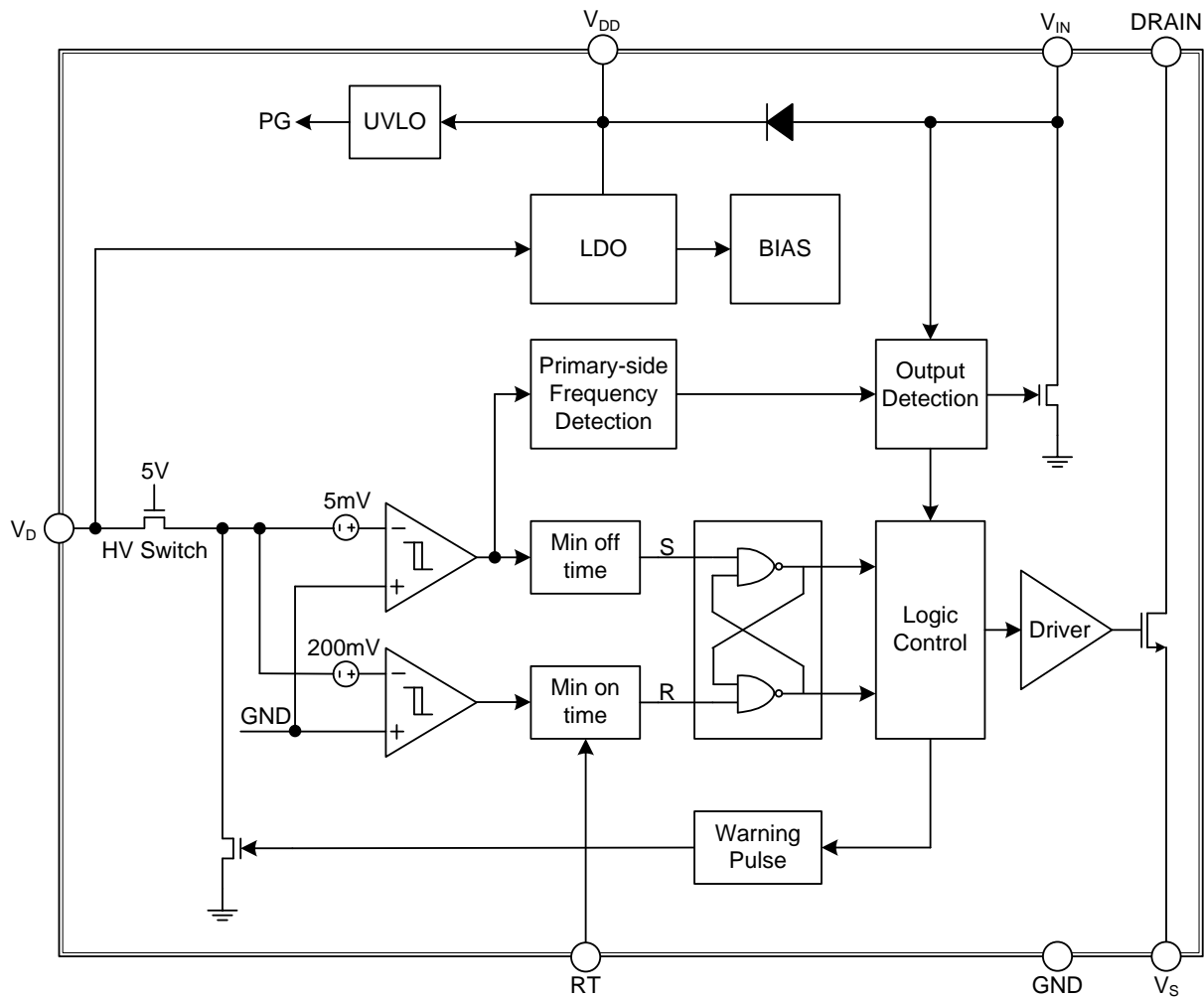

### ■ ABSOLUTE MAXIMUM RATING

PARAMETER	SYMBOL	RATINGS	UNIT
V <sub>IN</sub> Pin	V <sub>IN</sub>	-0.6 ~ 7	V
V <sub>DD</sub> Pin	V <sub>DD</sub>	-0.6 ~ 7	V
V <sub>D</sub> Pin	V <sub>D</sub>	-2.5 ~ 45 (Note 2)	V
V <sub>S</sub> Pin	V <sub>S</sub>	-0.6 ~ 7	V
RT Pin	RT	-0.6 ~ 7	V
DRAIN Pin	DRAIN	-0.6 ~ BV <sub>DSS</sub> (Note 3)	V
Min/Max Operating Junction Temperature	T <sub>J</sub>	-40 ~ +150	°C
Operating Ambient Temperature	T <sub>A</sub>	-20 ~ +85	°C
Min/Max Storage Temperature	T <sub>STG</sub>	-55 ~ +150	°C

- Notes: 1. Absolute maximum ratings are those values beyond which the device could be permanently damaged. Absolute maximum ratings are stress ratings only and functional device operation is not implied.  
 2. -2.5V applies to minimum duty cycle during normal operation only.  
 3. -0.6V is self-clamped.

### ■ RECOMMENDED OPERATING CONDITIONS

PARAMETER	SYMBOL	RATINGS	UNIT
V <sub>DD</sub> Supply Voltage	V <sub>DD</sub>	4 ~ 5.5	V

### ■ ELECTRICAL CHARACTERISTICS (T<sub>A</sub>=25°C, V<sub>DD</sub>=5V, unless otherwise noted)

PARAMETER	SYMBOL	TEST CONDITIONS	MIN	TYP	MAX	UNIT
<b>Supply Voltage (V<sub>DD</sub>)</b>						
Operation Current	I <sub>V<sub>DD</sub> Operation</sub>	Frequency @ V <sub>D</sub> =65KHz, V <sub>DD</sub> =5V		1.5	2.0	mA
		Frequency @ V <sub>D</sub> =2KHz, V <sub>DD</sub> =5V		0.5	0.7	
Minimum V <sub>DD</sub> Regulation Voltage	V <sub>DD_Regulation_Min</sub>			4.2		V
V <sub>DD</sub> Under Voltage Lockout Entry	U <sub>VLO (ON)</sub>		2.8	3.0	3.2	V
V <sub>DD</sub> Under Voltage Lockout Exit (Recovery)	U <sub>VLO (OFF)</sub>		2.9	3.1	3.3	V
<b>V<sub>D</sub> Detection Section</b>						
SR MOSFET Turn On Threshold Voltage Detection At V <sub>D</sub>	V <sub>TH_SR_act</sub>			-200		mV
SR MOSFET Turn Off Threshold Voltage Detection At V <sub>D</sub>	V <sub>TH_SR_deact</sub>			-5		mV
SR MOSFET Turn-On Propagation Delay	T <sub>Delay_On</sub>			100		ns
SR MOSFET Turn-Off Propagation Delay	T <sub>Delay_Off</sub>			75		ns
SR MOSFET Minimum On Time	T <sub>Min_On</sub>	RT=25KΩ		1.9		us
<b>RT Section</b>						
Voltage Reference At RT Pin	V <sub>RT</sub>		0.95	1	1.05	V

### ■ ELECTRICAL CHARACTERISTICS (T<sub>A</sub>=25°C, V<sub>DD</sub>=5V, unless otherwise noted)

PARAMETER	SYMBOL	TEST CONDITIONS	MIN	TYP	MAX	UNIT
<b>Over/Under Shoot Control Section</b>						
Output Delta Variation In System Output Undershoot Control At V <sub>IN</sub>	V <sub>IN_Delta</sub>			160		mV
Output Delta Variation Detection Enable Voltage At V <sub>IN</sub>	V <sub>IN_Delta_Enb</sub>			5.25		V
Output Delta Variation Detection Sample Frequency	F <sub>sample</sub>			15		KHz
System Output Undershoot Clamp Control Trigger Voltage At V <sub>IN</sub>	V <sub>IN_Low_Clamp</sub>		4.5	4.6	4.7	V
System Output 1st Overshoot Clamp Control Trigger Voltage At V <sub>IN</sub> With SR Frequency Lower Than 7.5KHz	V <sub>IN_High_Clamp_1st</sub>			5.65		V
System Output 2 <sup>nd</sup> Overshoot Clamp Control Trigger Voltage At V <sub>IN</sub>	V <sub>IN_High_Clamp_2nd</sub>			6.15		V
System Output Overshoot Clamp Current At V <sub>IN</sub>	I <sub>VIN_High_Clamp</sub>			100		mA
Warning Current Pulse Peak Value At V <sub>D</sub> When System Output Undershoot Is Detected At V <sub>IN</sub>	I <sub>V_D_Pulse</sub>			150		mA
Warning Current Pulse Width At V <sub>D</sub> When System Output Undershoot Is Detected At V <sub>IN</sub>	D <sub>Sr_pulse</sub>			2.5		uS
Warning Current Frequency At V <sub>D</sub> When System Output Undershoot Is Detected At V <sub>IN</sub>	F <sub>SW</sub>		27	30	33	KHz
Warning Signal Blanking Time After Secondary-Side Demagnetization	T <sub>delay</sub>			90		us
<b>SR MOSFET SECTION</b>						
MOSFET Drain-Source Breakdown Voltage	BV <sub>DSS</sub>	UTC USR5V10V	45			V
		UTC USR5V10W	50			V
		UTC USR5V10Z	50			V
On Resistance	R <sub>DS(ON)</sub>	UTC USR5V10V		30		mΩ
		UTC USR5V10W		15		mΩ
		UTC USR5V10Z		8		mΩ
Drain Current Continuous	I <sub>D</sub>	UTC USR5V10W	10			A

■ OPERATION DESCRIPTION

UTC **USR5V10X** is a high performance and versatile synchronous rectifier. It can emulate the behavior of Schottky diode rectifier which directly reduces power dissipation of the traditional rectifiers and indirectly reduces primary-side loss due to compounding of efficiency gains.

**Startup And Under Voltage Lockout (UVLO)**

UTC **USR5V10X** implements UVLO function during startup. When  $V_{DD}$  rises above UVLO (off), the IC wakes up from under voltage lock out state and enter normal operation. When  $V_{DD}$  drops below UVLO (on), the IC enter under voltage lock out state again and the SR gate is pulled low by 10K resistor on chip. In addition, there is a hysteresis window between UVLO (off) and UVLO (on) to make system work reliably.

**Synchronization Rectifier**

UTC **USR5V10X** controls the turn-on and turn-off of synchronization rectifier MOSFET (SR MOSFET) by detection of drain-source voltage. When demagnetization of transformer starts, the secondary-side current will flow through the body diode of SR MOSFET and the voltage at the drain will drop to about -700mV. As soon as UTC **USR5V10X** detects this negative voltage, the driver voltage is pulled high to turn on the SR MOSFET after very short delay time about 100nS, refer to Fig.1.

After the SR MOSFET is turned on, the drain voltage of SR MOSFET begins to rise based on its  $R_{DS(ON)}$  and secondary-side current. The drain voltage becomes higher with demagnetization going on. When the drain voltage rises above -5mV, the driver voltage will be pulled down to ground very quickly, refer to Fig.1

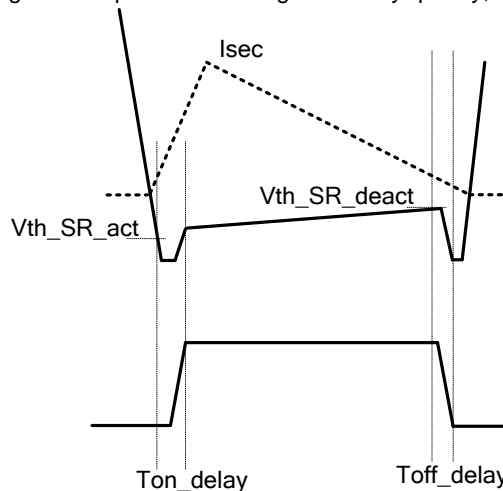

Fig. 1 SR MOSFET Turn-on And Turn-off Timing

**Adjustable Minimum On Time**

UTC **USR5V10X** offers adjustable minimum on time control. This timer can avoid effectively false turn-off due to high frequency interference caused by parasitic element at the start of secondary-side demagnetization.

$$T_{ON\_MIN} = 8 \times RT \times 10E (-11)$$

**Adaptive Minimum Off Time**

At the end of demagnetization, SR MOSFET will be turn off. The remaining current will flow through body diode again, which may result in negative voltage (about -700mV) appears at drain and SR MOSFET will turn on again. In addition, the resonance oscillation between the magnetization inductance and parasitic capacitance after demagnetization may cause negative drain voltage. These may turn on SR MOSFET by mistake. To avoid above mis-turn-on of SR MOSFET, constant minimum off time can be used to screen it. But it may disturb SR MOSFET operation. For reliable SR operation, proprietary adaptive minimum off time control is implemented in UTC **USR5V10X**, which can guarantee reliable synchronous rectification operation in DCM, QR.

## ■ OPERATION DESCRIPTION (Cont.)

### Output Voltage Under-Shoot Control

When a load transient event happens, the system output voltage may drop. UTC **USR5V10X** can prevent output voltage drop too low through direct detection of system output voltage. When the output voltage variation between the successive sample cycle exceeds 160mV, UTC **USR5V10X** can output 8 current pulses (typical peak value 150mA) at  $V_D$  pin with pulse width 2.5uS and 30KHz frequency to wake up primary side controller to switch the primary-side power MOSFET on to deliver more power to the loading in order to make output voltage back to regulation. In addition, if the system output voltage drops to threshold voltage determined by UTC **USR5V10X** (4.6V), the above primary side wake up process is still in effect.

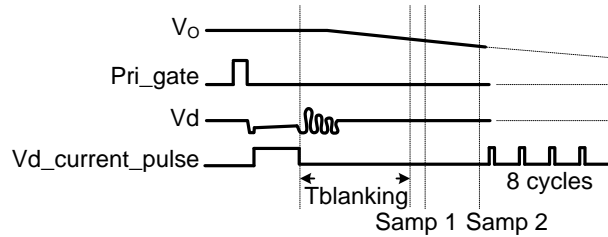

Fig. 2 Output Voltage Under-Shoot Control Timing Diagram

### Output Overshoot Clamp

For poor system design, there is usually output overshoot during startup and load transient. To facilitate system design, UTC **USR5V10X** can detect output overshoot condition and prevent overshoot happen. When output voltage rises to meet the inner threshold, UTC **USR5V10X** will open a discharge path from  $V_{IN}$  to ground to clamp the system output voltage, so the system output overshoot can be prevented.

### PCB Layout Consideration

The following rules should be followed in UTC **USR5V10X** PCB Layout:

#### The Area of Power Loop

The area of the secondary current loop including the UTC **USR5V10X** and the output capacitor should be as small as possible to reduce EMI radiation. And the PCB trace must be wide and short for thermal consideration.

#### Ground Path

The  $V_S$  pin should be shorted directly to the GND pin under the bottom of UTC **USR5V10X** before single point connected to the negative node of the output capacitor. This increases the copper area at the bottom of UTC **USR5V10X** for heat dissipation and reduce the impedance between  $V_S$  pin and GND pin.

#### Bypass Capacitor

The bypass capacitor on  $V_{DD}$  should be placed as close as possible to the  $V_{DD}$  pin. And the negative node of  $V_{DD}$  capacitor should be connected directly to the GND pin.

#### $V_D$ Pin and DRAIN Pin

The resistor in the Fig.3 is recommended to be placed between the  $V_D$  pin and the DRAIN pin for improving the ESD ability. The recommended value of the resistor is 10ohm with package type of 0805. No trace under this resistor is required.

■ OPERATION DESCRIPTION (Cont.)

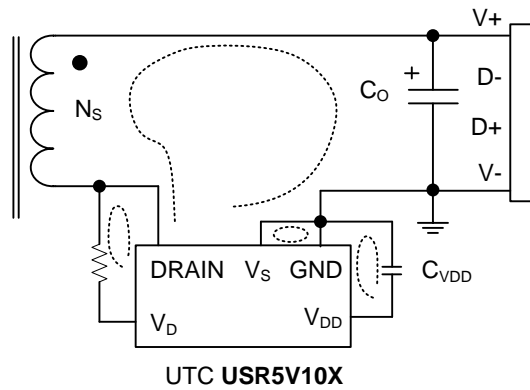
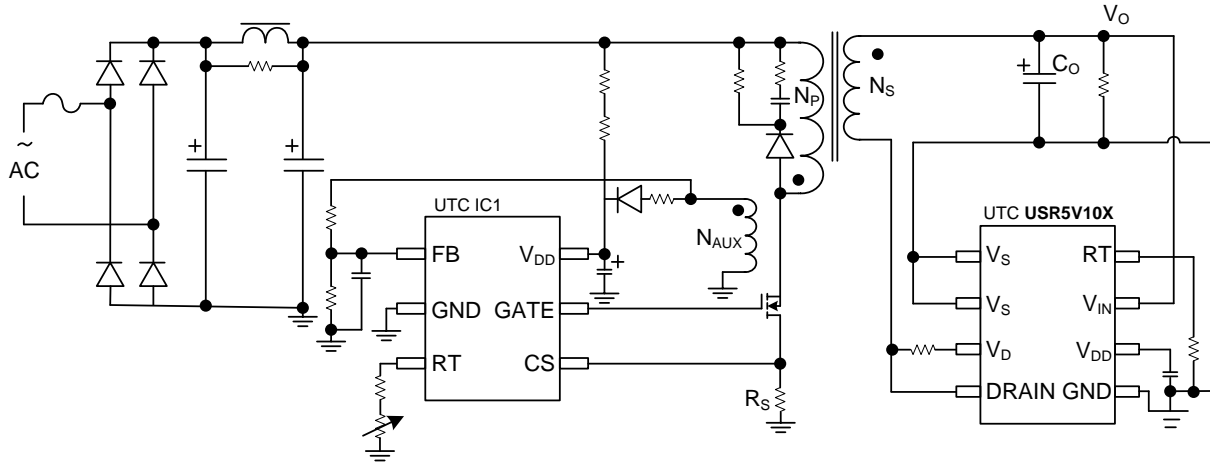

Fig. 3 Proper Loop At The Secondary Side Of The Flyback With UTC USR5V10X



■ TYPICAL APPLICATION CIRCUIT



UTC assumes no responsibility for equipment failures that result from using products at values that exceed, even momentarily, rated values (such as maximum ratings, operating condition ranges, or other parameters) listed in products specifications of any and all UTC products described or contained herein. UTC products are not designed for use in life support appliances, devices or systems where malfunction of these products can be reasonably expected to result in personal injury. Reproduction in whole or in part is prohibited without the prior written consent of the copyright owner. UTC reserves the right to make changes to information published in this document, including without limitation specifications and product descriptions, at any time and without notice. This document supersedes and replaces all information supplied prior to the publication hereof.