



UD32121

LINEAR INTEGRATED CIRCUIT

1.2A, 32V, 1.4MHz STEP-DOWN CONVERTER

DESCRIPTION

The UTC **UD32121** is a monolithic step-down switching mode converter with a built-in power MOSFET. It regulates input voltages from 4.5V to 32V down to an output voltage as low as 0.81V, and supplies up to 1.2A of load current.

Current mode operation provides fast transient response and eases loop stabilization. Fault condition protection includes cycle-by-cycle current limiting and thermal shutdown.

The UTC **UD32121** requires a minimum number of readily available standard external components.

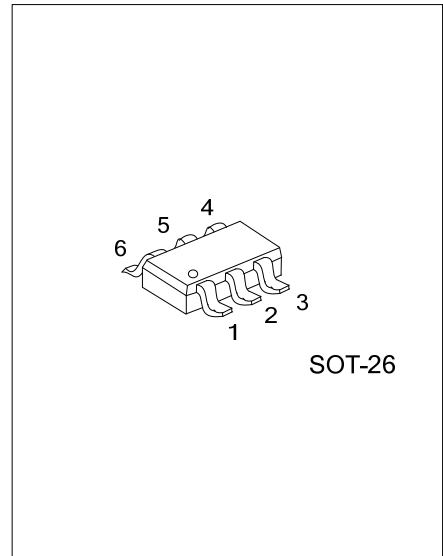

APPLICATIONS

- * Distributed Power Systems
- * Battery Charger
- * Pre-Regulator for Linear Regulators
- * WLED Drivers

FEATURES

- * 1.2A Peak Output Current
- * 0.35Ω Internal Power MOSFET Switch
- * Stable with Low ESR Output Ceramic Capacitors
- * Up to 92% Efficiency
- * 0.1μA Shutdown Mode
- * Fixed 1.4MHz Frequency
- * Thermal Shutdown
- * Cycle-by-Cycle Over Current Protection
- * Wide 4.5V to 32V Operating Input Range
- * Output Adjustable from 0.81V to 15V

ORDERING INFORMATION

| Ordering Number | | Package | Packing |
|-----------------|----------------|---------|-----------|
| Lead Free | Halogen Free | | |
| UD32121L-AG6-R | UD32121G-AG6-R | SOT-26 | Tape Reel |

| | | |
|----------------|------------------|---|
| UD32121G-AG6-R | (1)Packing Type | (1) R: Tape Reel |
| | (2)Package Type | (2) AG6: SOT-26 |
| | (3)Green Package | (3) G: Halogen Free and Lead Free, L: Lead Free |

MARKING

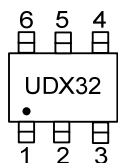

PIN CONFIGURATION

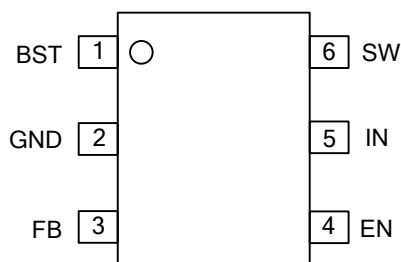

PIN DESCRIPTION

| PIN NO. | PIN NAME | DESCRIPTION |
|---------|-----------------|--|
| 1 | BST | High-Side Gate Drive Boost Input. BS supplies the drive for the high-side N-Channel MOSFET switch. Connect a 0.01 μ F or greater capacitor from SW to BST to power the high side switch. |
| 2 | GND | Ground. |
| 3 | FB | Feedback. An external resistor divider from the output to GND, tapped to the FB pin sets the output voltage. To prevent current limit run away during a short circuit fault condition, the frequency foldback comparator lowers the oscillator frequency when the FB voltage is below 250mV. |
| 4 | EN | On/Off Control Input. Pull EN above 1.2V to turn the device on. For automatic enable, connect a 100k Ω resistor between this pin and Vin pin. |
| 5 | V _{IN} | Supply Voltage. The UD32121 operates from a +4.5V to +32V unregulated input. C1 is needed to prevent large voltage spikes from appearing at the input. |
| 6 | SW | Power Switching Output. SW is the switching node that supplies power to the output. Connect the output LC filter from SW to the output load. Note that a capacitor is required from SW to BS to power the high-side switch. |

■ BLOCK DIAGRAM

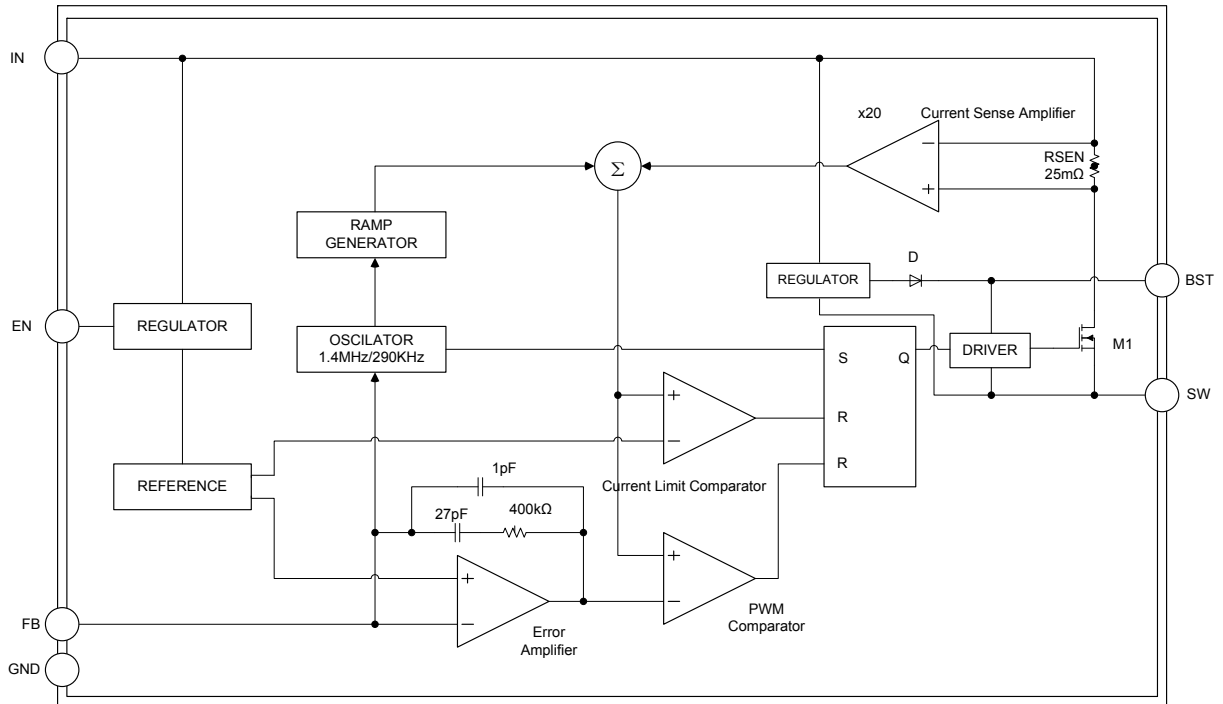

■ ABSOLUTE MAXIMUM RATING ($T_A=25^{\circ}\text{C}$, unless otherwise specified)

| PARAMETER | SYMBOL | RATINGS | UNIT |
|-----------------------------|------------------|---------------------|------|
| V _{CC} Pin Voltage | V _{IN} | 33 | V |
| SW Pin Voltage | V _{SW} | 33 | V |
| BOOST Trap Voltage | V _{BST} | V _{SW} +6V | V |
| All Other Pins Voltage | | -0.3V ~ + 6V | V |
| Power Dissipation | P _D | 380 | mW |
| Junction Temperature Range | T _J | +150 | °C |
| Storage Temperature Range | T _{STG} | -65 ~ +150 | °C |

Notes: 1. Absolute maximum ratings are those values beyond which the device could be permanently damaged. Absolute maximum ratings are stress ratings only and functional device operation is not implied.

■ RECOMMENDED OPERATING CONDITIONS

| PARAMETER | SYMBOL | RATINGS | UNIT |
|-------------------------------|------------------|------------|------|
| Input Supply Voltage | V _{IN} | 4.5 ~ 32 | V |
| Output Voltage | V _{OUT} | 0.81 ~ 15 | V |
| Ambient Temperature | T _A | -40 ~ +125 | °C |
| input current into the EN pin | | 300 | μA |

Note: The device is not guaranteed to function outside of its operating conditions.

■ THERMAL CHARACTERISTICS

| PARAMETER | SYMBOL | RATINGS | UNIT |
|---------------------|-----------------|---------|------|
| Junction To Ambient | θ _{JA} | 260 | °C/W |

■ ELECTRICAL CHARACTERISTICS

(V_{IN} = 12V, T_A=25°C, unless otherwise specified)

| PARAMETER | SYMBOL | TEST CONDITIONS | MIN | TYP | MAX | UNIT |
|---|------------------------|--|-------|-------|-------|------|
| Quiescent Current | I _Q | V _{EN} =2V, V _{FB} =1V | | 0.8 | | mA |
| Shutdown Current | I _{SHDN} | V _{EN} =0V. | | 1 | 3 | μA |
| Switch-On Resistance (Note 6) | R _{DS-ON} | | | 0.35 | | Ω |
| Switch Leakage Current | I _{SWLKG} | V _{EN} =0V, V _{SW} =0V | | | 10 | uA |
| Current Limit (Note 6) | I _{LIMIT} | | | 1.8 | | A |
| Oscillation frequency | F _{SW} | | | 1.4 | | MHz |
| Fold-Back Frequency | F _{SB} | V _{FB} =0V | | 290 | | KHz |
| Max Duty Cycle | D _{MAX} | V _{FB} =0.6V | | 87 | | % |
| Minimum On Time (Note 6) | T _{ON MIN} | | | 100 | | nS |
| Feedback Voltage | V _{FB} | 4.5V ≤ V _{IN} ≤ 32V | 0.790 | 0.810 | 0.830 | V |
| EN Input High Voltage | V _{EN H} | V _{EN} Rising | 1.2 | | | V |
| EN Input Low Voltage | | | | | 0.4 | V |
| EN input current | | V _{EN} =2V | | 2.1 | | uA |
| | | V _{EN} =0V | | 0.1 | | |
| V _{IN} UVLO Threshold-Rising | V _{UVLO(Vth)} | V _{IN} Rising | | 2.8 | | V |
| V _{IN} UVLO Threshold Hysteresis | | | | 150 | | mV |
| Thermal Shutdown (Note 6) | T _{SD} | | | 150 | | °C |
| Thermal Hysteresis (Note 6) | | | | 25 | | °C |

Note: Guaranteed by design.

■ TYPICAL APPLICATION CIRCUIT

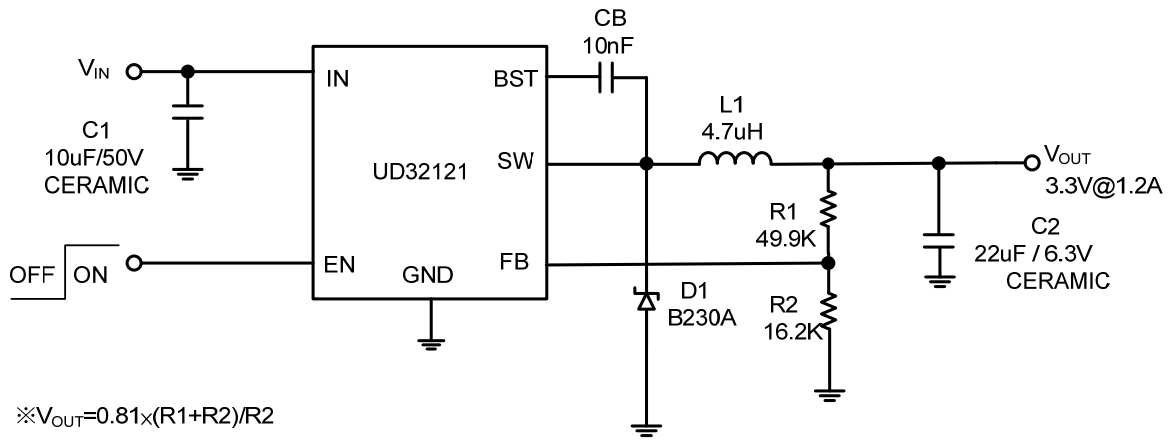

UTC assumes no responsibility for equipment failures that result from using products at values that exceed, even momentarily, rated values (such as maximum ratings, operating condition ranges, or other parameters) listed in products specifications of any and all UTC products described or contained herein. UTC products are not designed for use in life support appliances, devices or systems where malfunction of these products can be reasonably expected to result in personal injury. Reproduction in whole or in part is prohibited without the prior written consent of the copyright owner. UTC reserves the right to make changes to information published in this document, including without limitation specifications and product descriptions, at any time and without notice. This document supersedes and replaces all information supplied prior to the publication hereof.