



UCD4049UB

Preliminary

CMOS IC

CMOS HEX INVERTERS

■ DESCRIPTION

The **UCD4049UB** devices are inverters with unbuffered output, and feature logic-level conversion using only one supply voltage (V_{CC}). The input-signal high level (V_{IH}) can exceed the V_{CC} supply voltage when these devices are used for logic-level conversions. These devices are intended for use as CMOS to DTL/TTL converters and can drive directly two DTL/TTL loads.

■ FEATURES

- * High Sink Current for Driving 2 TTL Loads
- * High-To-Low Level Logic Conversion
- * Maximum Input Current of 1uA at 18V Over Full Package Temperature Range
- * 5V, 10V and 15V Parametric Ratings

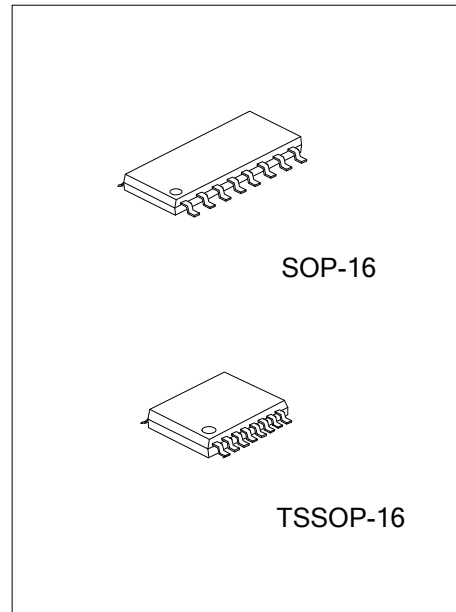

■ ORDERING INFORMATION

Ordering Number		Package	Packing
Lead Free	Halogen Free		
UCD4049UBL-S16-R	UCD4049UBG-S16-R	SOP-16	Tape Reel
UCD4049UBL-P16-R	UCD4049UBG-P16-R	TSSOP-16	Tape Reel

<p>UCD4049UBG-S16-R</p> <ul style="list-style-type: none"> (1) Packing Type (2) Package Type (3) Green Package 	<ul style="list-style-type: none"> (1) R: Tape Reel (2) S16: SOP-16, TSSOP-16 (3) G: Halogen Free and Lead Free, L: Lead Free
---	--

■ MARKING

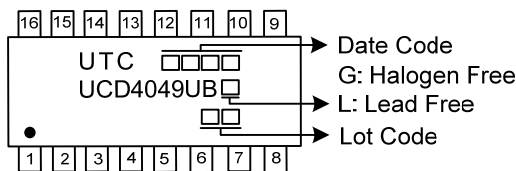

■ PIN CONFIGURATION

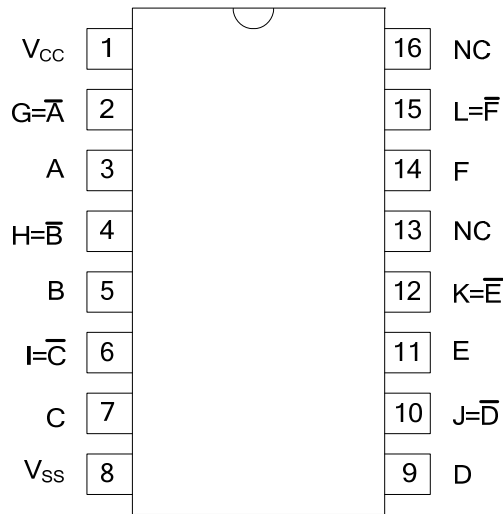

■ FUNCTION TABLE (each gate)

INPUT(A)	OUTPUT(G)
H	L
L	H

■ LOGIC DIAGRAM (positive logic)

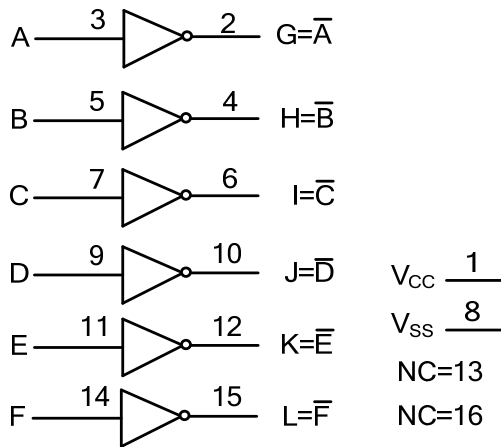

■ ABSOLUTE MAXIMUM RATING ($T_A=25^{\circ}\text{C}$, unless otherwise specified)

PARAMETER	SYMBOL	RATINGS	UNIT
Supply Voltage	V_{CC}	-0.5 ~ 18	V
Input Voltage	V_{IN}	-0.5 ~ $V_{CC}+0.5$	V
Output Voltage	V_{OUT}	-0.5 ~ $V_{CC}+0.5$	V
Storage Temperature	T_{STG}	-65 ~ +150	$^{\circ}\text{C}$

Note: Absolute maximum ratings are those values beyond which the device could be permanently damaged. Absolute maximum ratings are stress ratings only and functional device operation is not implied.

■ RECOMMENDED OPERATING CONDITIONS

PARAMETER	SYMBOL	RATINGS	UNIT
Supply Voltage	V_{CC}	3 ~ 15	V
Operating Temperature	T_{OPR}	-40 ~ +125	$^{\circ}\text{C}$

■ THERMAL DATA

PARAMETER	SYMBOL	RATINGS	UNIT	
Junction to Ambient	SOP-16	θ_{JA}	73	$^{\circ}\text{C/W}$
	TSSOP-16		108	$^{\circ}\text{C/W}$

■ ELECTRICAL CHARACTERISTICS ($T_A=25^{\circ}\text{C}$, unless otherwise specified)

PARAMETER	SYMBOL	TEST CONDITIONS	MIN	TYP	MAX	UNIT
High-Level Input Voltage	V_{IH}	$V_{CC}=5\text{V}, V_O=0.5\text{V}$	4.0			V
		$V_{CC}=10\text{V}, V_O=1.0\text{V}$	8.0			
		$V_{CC}=15\text{V}, V_O=1.5\text{V}$	12.5			
Low-Level Input Voltage	V_{IL}	$V_{CC}=5\text{V}, V_O=4.5\text{V}$			1.0	V
		$V_{CC}=10\text{V}, V_O=9.0\text{V}$			2.0	
		$V_{CC}=15\text{V}, V_O=13.5\text{V}$			2.5	
High-Level Output Voltage	V_{OH}	$V_{CC}=5\text{V}, V_I=0\text{V}, \text{No Load}$	4.95	5		V
		$V_{CC}=10\text{V}, V_I=0\text{V}, \text{No Load}$	9.95	10		
		$V_{CC}=15\text{V}, V_I=0\text{V}, \text{No Load}$	14.95	15		
Low-Level Output Voltage	V_{OL}	$V_{CC}=5\text{V}, V_I=5\text{V}, \text{No Load}$		0	0.05	V
		$V_{CC}=10\text{V}, V_I=10\text{V}, \text{No Load}$		0	0.05	
		$V_{CC}=15\text{V}, V_I=15\text{V}, \text{No Load}$		0	0.05	
High-Level Output Current (Note)	I_{OH}	$V_{CC}=5\text{V}, V_O=4.6\text{V}$	-0.65	-1.2		mA
		$V_{CC}=5\text{V}, V_O=2.5\text{V}$	-2.1	-7.2		
		$V_{CC}=10\text{V}, V_O=9.5\text{V}$	-1.65	-3.5		
		$V_{CC}=15\text{V}, V_O=13.5\text{V}$	-4.3	-13		
Low-Level Output Current (Note)	I_{OL}	$V_{CC}=4.5\text{V}, V_O=0.4\text{V}$	2.6	6.8		mA
		$V_{CC}=5\text{V}, V_O=0.4\text{V}$	3.2	7.8		
		$V_{CC}=10\text{V}, V_O=0.5\text{V}$	8.0	16		
		$V_{CC}=15\text{V}, V_O=1.5\text{V}$	24.0	67		
Input Leakage Current	$I_{I(LEAK)}$	$V_{CC}=15\text{V}, V_{IN} = V_{CC} \text{ or } \text{GND}$			0.1	μA
Quiescent Supply Current	I_{DD}	$V_{CC}=5\text{V}, V_{IN} = V_{CC} \text{ or } V_{SS}, I_{OUT} = 0$		0.02	1	μA
		$V_{CC}=10\text{V}, V_{IN} = V_{CC} \text{ or } V_{SS}, I_{OUT} = 0$		0.02	2	
		$V_{CC}=15\text{V}, V_{IN} = V_{CC} \text{ or } V_{SS}, I_{OUT} = 0$		0.02	4	

Note: I_{OL} and I_{OH} are tested one output at a time

■ SWITCHING CHARACTERISTICS

($T_A=25^\circ\text{C}$, Input: $t_R=t_F=20\text{ns}$, $C_L=50\text{pF}$, $R_L=200\text{K}\Omega$, unless otherwise specified)

PARAMETER	SYMBOL	TEST CONDITIONS	MIN	TYP	MAX	UNIT
Propagation delay from Input(A or B) to Output(Y)	t_{PLH}	$V_{CC}=5\text{V}$		35	85	ns
		$V_{CC}=10\text{V}$		20	45	
		$V_{CC}=15\text{V}$		15	35	
	t_{PHL}	$V_{CC}=5\text{V}$		20	65	
		$V_{CC}=10\text{V}$		15	40	
		$V_{CC}=15\text{V}$		10	30	
Transition Time	t_{TLH}	$V_{CC}=5\text{V}$		50	120	ns
		$V_{CC}=10\text{V}$		35	55	
		$V_{CC}=15\text{V}$		30	45	
	t_{THL}	$V_{CC}=5\text{V}$		25	60	
		$V_{CC}=10\text{V}$		20	40	
		$V_{CC}=15\text{V}$		15	30	

■ OPERATING CHARACTERISTICS ($T_A=25^\circ\text{C}$, unless otherwise specified)

PARAMETER	SYMBOL	TEST CONDITIONS	MIN	TYP	MAX	UNIT
Average Input Capacitance	C_{IN}	Any Input		15	22.5	pF

■ TEST CIRCUIT AND WAVEFORMS

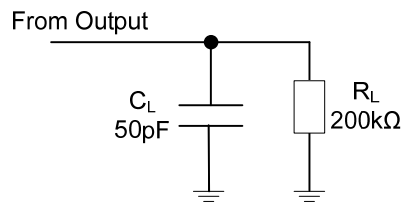

Fig 1. Definitions for test circuit

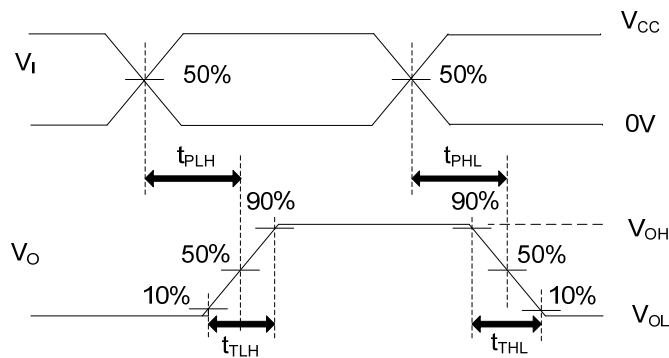

Fig 2. Propagation Delay Times

Note: C_L includes probe and jig capacitance.

UTC assumes no responsibility for equipment failures that result from using products at values that exceed, even momentarily, rated values (such as maximum ratings, operating condition ranges, or other parameters) listed in products specifications of any and all UTC products described or contained herein. UTC products are not designed for use in life support appliances, devices or systems where malfunction of these products can be reasonably expected to result in personal injury. Reproduction in whole or in part is prohibited without the prior written consent of the copyright owner. UTC reserves the right to make changes to information published in this document, including without limitation specifications and product descriptions, at any time and without notice. This document supersedes and replaces all information supplied prior to the publication hereof.