



### ELECTRIC TOY DC MOTOR DRIVE CIRCUIT

#### DESCRIPTION

UTC **UMD9119** is an integrated circuit driven by a single channel toy DC motor which is designed for low-voltage operated system. It has H bridge driver and uses the PMOS and NMOS power transistors with low output resistance. Low on-resistance ensures the circuit to consume lower power in operating at a continuous current, and ensures the circuit to operate stably for a long time.

UTC **UMD9119** has on-chip temperature protection function. When load motor with low internal resistance is in locked rotor, UTC **UMD9119** output current will increase momentarily, power dissipation of the circuit will go up sharply, and the chip temperature will soar. But, when the chip temperature exceeds a maximum temperature point (typically 150°C) set by internal temperature protection circuit, the internal circuit will switch off the on-chip power switching transistor of UTC **UMD9119**, and switch off load current, preventing potential safety hazards such as fuming, igniting, etc. Of plastic package caused by over temperature. Only after having confirmed that the circuit has returned to safety temperature, can the on-chip temperature hysteresis circuit be allowed to re-control the circuit.

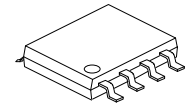

SOP-8

#### FEATURES

- \* H bridge driver of internal PMOS/NMOS power switches
- \* Can realize 4 functions (forward、backward、standby、brake) of load motor
- \* Low output impedance
- \* Low standby current (typ.0.1μA)
- \* Low static operational current (typ.300μA, V<sub>CC</sub>=3V)
- \* On-chip thermal shut down (TSD) with hysteresis

#### ORDERING INFORMATION

Ordering Number		Package	Packing
Lead Free	Halogen Free		
UMD9119L-S08-R	UMD9119G-S08-R	SOP-8	Tape Reel

<p>UMD9119G-S08-R</p> <ul style="list-style-type: none"> <li>(1)Packing Type</li> <li>(2)Package Type</li> <li>(3)Green Package</li> </ul>	<ul style="list-style-type: none"> <li>(1) R: Tape Reel</li> <li>(2) S08: SOP-8</li> <li>(3) G: Halogen Free and Lead Free, L: Lead Free</li> </ul>
--	---

### MARKING

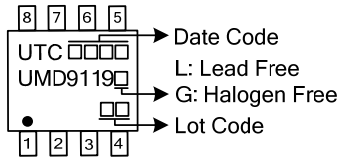

### PIN CONFIGURATION

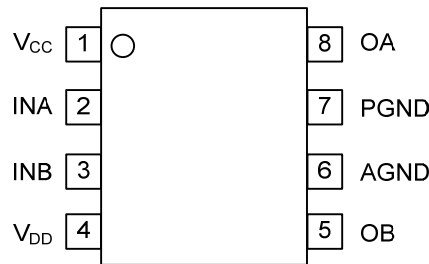

### PIN DESCRIPTION

PIN NO.	PIN NAME	DESCRIPTION
1	V <sub>CC</sub>	Power supply of logic control circuit
2	INA	Forward rotation logic input
3	INB	Backward rotation logic input
4	V <sub>DD</sub>	Power supply
5	OB	Backward rotation output
6	AGND	Ground of logic control circuit
7	PGND	Ground of output power transistor
8	OA	Forward rotation output

### BLOCK DIAGRAM

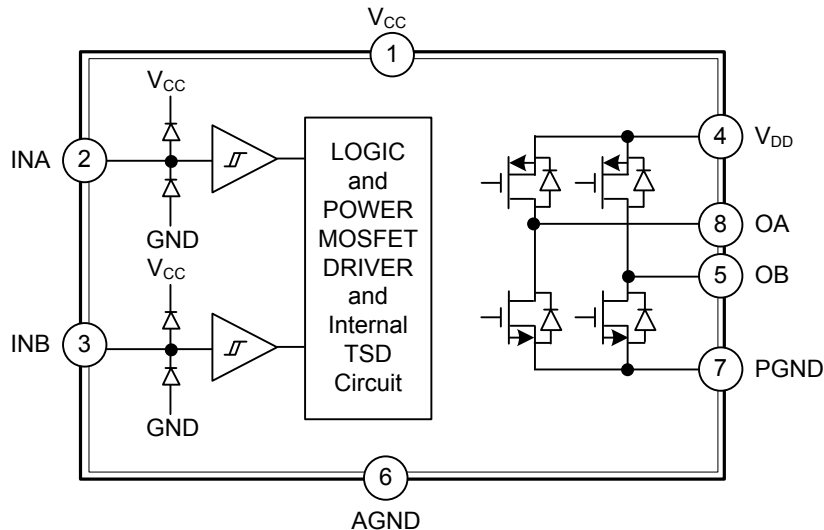

### LOGIC TRUTH TABLE

INA	INB	OA	OB	FUNCTION
L	L	Z	Z	Standby (Stop)
H	L	H	L	Forward rotation
L	H	L	H	Backward rotation
H	H	L	L	Brake

■ ABSOLUTE MAXIMUM RATING (T<sub>A</sub>=25°C, unless otherwise specified)

PARAMETER	SYMBOL	RATINGS	UNIT
Maximum Logic and Control Supply Voltage	V <sub>CC</sub>	6.5	V
Maximum Output Supply Voltage	V <sub>DD</sub>	6.5	V
Maximum External Output Voltage	V <sub>OUT</sub>	V <sub>DD</sub>	V
Maximum External Input Voltage	V <sub>IN</sub>	V <sub>CC</sub>	V
Peak Output Current/Channel	I <sub>OUT PEAK</sub>	2.5	A
Junction Temperature	T <sub>J</sub>	+150	°C
Operational Temperature Range	T <sub>OPR</sub>	-20 ~ +85	°C
Storage Temperature	T <sub>STG</sub>	-55 ~ +150	°C

Notes: 1. Absolute maximum ratings are those values beyond which the device could be permanently damaged.

Absolute maximum ratings are stress ratings only and functional device operation is not implied.

2. Maximum power dissipation at different ambient can be obtained from the following formula

$$P_D = (T_J - T_A) / \theta_{JA}$$

Where T<sub>J</sub> is junction temperature with the circuit working, and T<sub>A</sub> is the ambient temperature with the circuit working.

3. Method of calculation of circuit power dissipation

$$P = I^2 \times R$$

Where P is circuit power dissipation, I is continuous output current, and R is circuit output on-resistance.

Circuit power dissipation P must be smaller than maximum power dissipation P<sub>D</sub>.

■ RECOMMENDED OPERATIONAL CONDITIONS (T<sub>A</sub>=25°C, unless otherwise specified)

PARAMETER	SYMBOL	RATINGS	UNIT
Maximum Logic and Control Supply Voltage	V <sub>CC</sub>	5.0	V
Maximum Output Supply Voltage	V <sub>DD</sub>	6.0	V

Note: Logic control power supply V<sub>CC</sub> and power supply V<sub>DD</sub> are fully separate internally, and can supply electricity separately.

■ THERMAL DATA

PARAMETER	SYMBOL	RATINGS	UNIT
Junction to Ambient	θ <sub>JA</sub>	143	°C/W

■ ELECTRICAL CHARACTERISTICS (T<sub>A</sub>=25°C, V<sub>CC</sub>=3V, V<sub>DD</sub>=3V unless otherwise stated)

PARAMETER	SYMBOL	TEST CONDITIONS	MIN	TYP	MAX	UNIT
V <sub>CC</sub> Standby Current	I <sub>CCST</sub>	I <sub>NA</sub> =I <sub>NB</sub> =L, V <sub>DD</sub> =V <sub>CC</sub> =6V		0	10	μA
V <sub>DD</sub> Standby Current	I <sub>VDDST</sub>			0	10	μA
V <sub>CC</sub> Static Supply Current	I <sub>CC</sub>	I <sub>NA</sub> =H, I <sub>NB</sub> =L or I <sub>NA</sub> =L, I <sub>NB</sub> =H or I <sub>NA</sub> =H, I <sub>NB</sub> =H		0.3	1.0	mA
V <sub>DD</sub> Static Supply Current	I <sub>VDD</sub>	I <sub>NA</sub> =H, I <sub>NB</sub> =L or I <sub>NA</sub> =L, I <sub>NB</sub> =H or I <sub>NA</sub> =H, I <sub>NB</sub> =H		0.1	1.5	mA
Input High Level	V <sub>INH</sub>		0.8×V <sub>CC</sub>			V
Input Low Level	V <sub>INL</sub>				0.2×V <sub>CC</sub>	V
Output Resistance	R <sub>ON</sub>	I <sub>O</sub> =±200mA		0.6	0.9	Ω
Spark-Killing Diode Leakage Current	I <sub>DLEAK</sub>				100	μA
Spark-Killing Diode Voltage	V <sub>D</sub>	I <sub>OUT</sub> =400mA		0.9		V
Protection Temperature	T <sub>SD</sub>			150		°C
TSD hysteresis	T <sub>SDH</sub>			30		°C

■ TYPICAL WAVEFORM

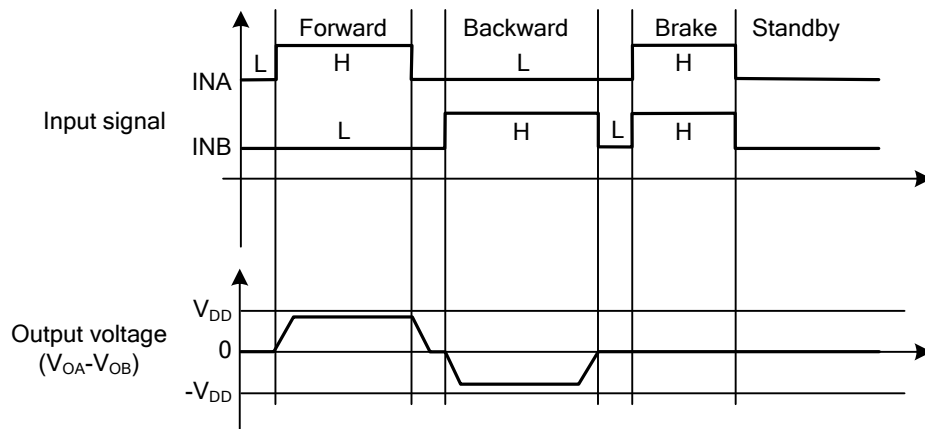

■ APPLICATION INFORMATION

**Baseline Mode**

a) Standby mode

In standby mode,  $INA=INB=L$ . All internal circuits, including the drive power tube, are off state. Circuit consumption is extremely low. In this mode, OA and OB both are in high-impedance state.

b) Forward mode

The forward mode is defined as:  $INA=H, INB=L$ , at this point the motor drive end OA outputs high level, and the motor drive end OB outputs low level, then the motor drives the current into the motor from the OA, and out from the OB to the ground. This motor rotation mode is defined as the forward mode.

c) Backward mode

The backward mode is defined as:  $INA=L, INB=H$ , at this point the motor drive end OB outputs high level, and the motor drive end OA outputs low level, then the motor drives the current into the motor from the OB, and out from the OA to the ground. This motor rotation mode is defined as the backward mode.

d) Brake mode

The brake mode is defined as:  $INA=H, INB=H$ , at this point motor drive ends OA and OB both output low level, and the energy stored in the motor will be quickly released through the OA end's NMOS tube or the OB end's NMOS tube, so the motor will stop turning in a short time.

Note: in brake mode, circuit will consume static power.

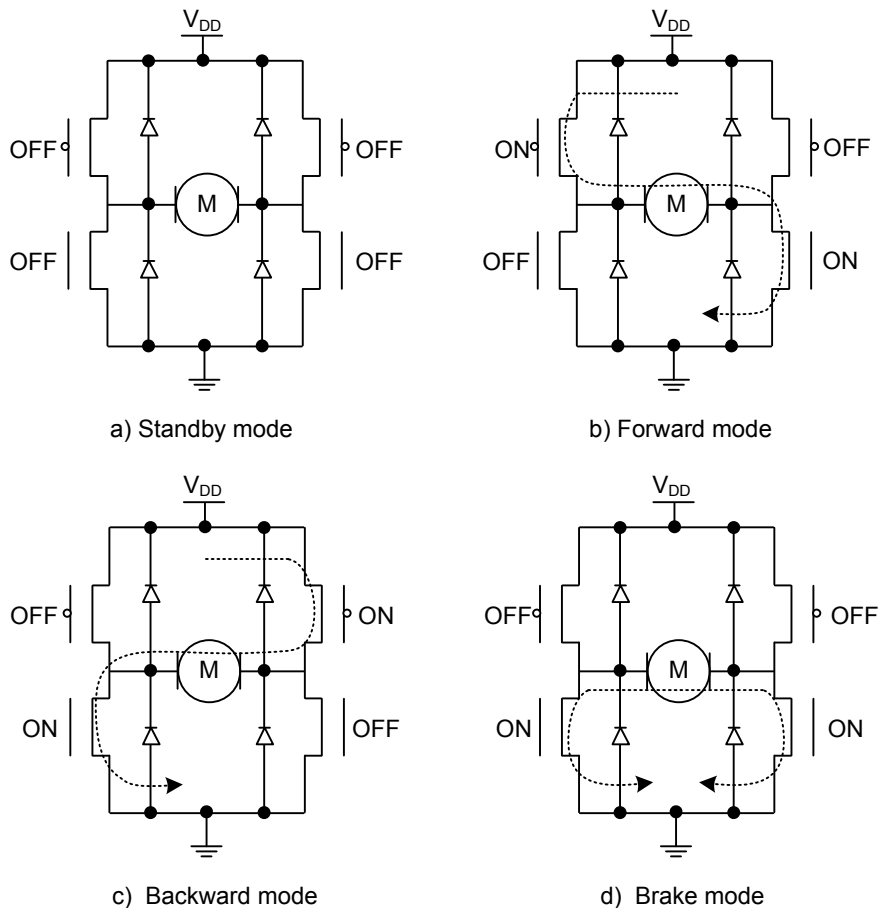

■ TYPICAL APPLICATION CIRCUIT

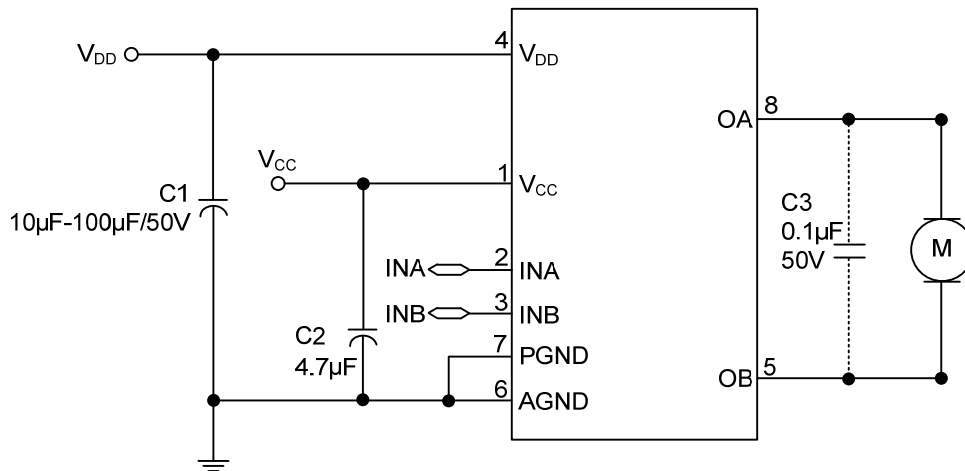

UTC assumes no responsibility for equipment failures that result from using products at values that exceed, even momentarily, rated values (such as maximum ratings, operating condition ranges, or other parameters) listed in products specifications of any and all UTC products described or contained herein. UTC products are not designed for use in life support appliances, devices or systems where malfunction of these products can be reasonably expected to result in personal injury. Reproduction in whole or in part is prohibited without the prior written consent of the copyright owner. UTC reserves the right to make changes to information published in this document, including without limitation specifications and product descriptions, at any time and without notice. This document supersedes and replaces all information supplied prior to the publication hereof.