



UFR1060

FAST RECOVERY EPITAXIAL DIODE

SUPERFAST RECOVERY RECTIFIER

DESCRIPTION

The UTC **UFR1060** is a superfast recovery rectifier, it uses UTC's advanced technology to provide customers with low forward voltage drop, low leakage, high current capability and high surge capability etc. These characteristics make it ideal for heavy duty applications that demand long term reliability. also fit into auxiliary functions such as snubber, bootstrap, and demagnetization applications.

FEATURES

- * Ultra-Fast Recovery Time for High Efficiency
- * Low Forward Voltage Drop, High Current Capability and Low Power Loss

SYMBOL

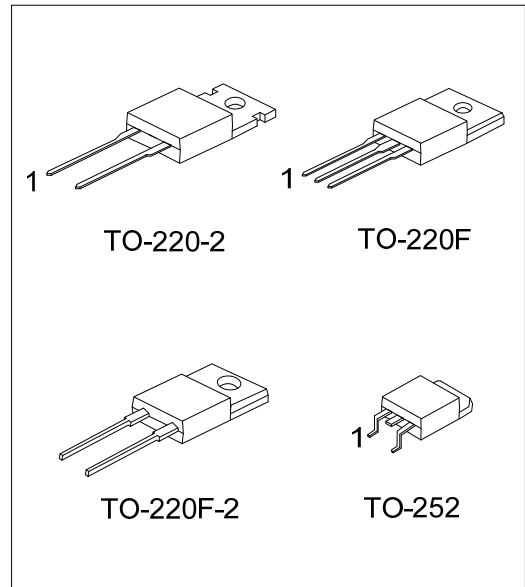
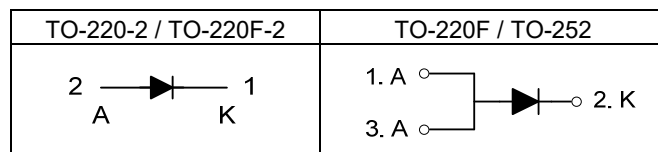

ORDERING INFORMATION

Ordering Number		Package	Pin Assignment			Packing
Lead Free	Halogen Free		1	2	3	
UFR1060L-TA2-T	UFR1060G-TA2-T	TO-220-2	K	A	-	Tube
UFR1060L-TF32-T	UFR1060G-TF32-T	TO-220F-2	K	A	-	Tube
UFR1060L-TF3-T	UFR1060G-TF3-T	TO-220F	A	K	A	Tube
UFR1060L-TN3-R	UFR1060G-TN3-R	TO-252	A	K	A	Tape Reel

Note: Pin Assignment: A: Anode K: Cathode

<p>UFR1060G-TA2-T</p>	<p>(1) T: Tube, R: Tape Reel (2) TA2: TO-220-2, TF32: TO-220F-2 TF3: TO-220F, TN3: TO-252 (3) G: Halogen Free and Lead Free, L: Lead Free</p>
-----------------------	--

MARKING

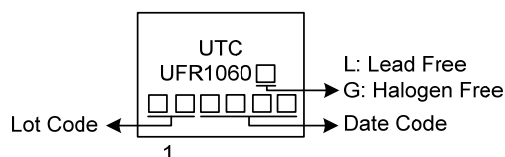

UFR1060

FAST RECOVERY EPITAXIAL DIODE

■ ABSOLUTE MAXIMUM RATINGS ($T_A=25^{\circ}\text{C}$, unless otherwise specified)

Ratings at 25°C ambient temperature unless otherwise specified. Resistive or inductive load, 60Hz.

PARAMETER	SYMBOL	RATINGS	UNIT
Repetitive Peak Reverse Voltage	V_{RRM}	600	V
Average forward current, $\delta=0.5\%$	$I_{F(AV)}$	10	A
Surge non repetitive forward current	I_{FSM}	70	A
Operating Junction Temperature	T_J	+150	$^{\circ}\text{C}$
Storage Temperature Range	T_{STG}	-65 ~ +150	$^{\circ}\text{C}$

Note: Absolute maximum ratings are those values beyond which the device could be permanently damaged. Absolute maximum ratings are stress ratings only and functional device operation is not implied.

■ THERMAL DATA

PARAMETER	SYMBOL	RATINGS	UNIT
Junction to Case	TO-220-2	2	$^{\circ}\text{C}/\text{W}$
	TO-220F-2	4.17	$^{\circ}\text{C}/\text{W}$
	TO-220F		
	TO-252	3.1	$^{\circ}\text{C}/\text{W}$

■ ELECTRICAL CHARACTERISTICS

Ratings at 25°C ambient temperature unless otherwise specified. Resistive or inductive load, 60Hz

PARAMETER	SYMBOL	TEST CONDITIONS	MIN	TYP	MAX	UNIT
Forward voltage drop (Note 1)	V_F	$I_F=10\text{A}$	$T_J=25^{\circ}\text{C}$		1.7	V
			$T_J=125^{\circ}\text{C}$		1.6	V
Instantaneous Reverse Current (Note 2)	I_R	$V_R=V_{RRM}$	$T_J=25^{\circ}\text{C}$		10	μA
			$T_J=125^{\circ}\text{C}$		100	μA
Reverse recovery time	t_{rr}	$I_F=1.0\text{A}, V_R=30\text{V}, dI_F/dt=-200\text{A}/\mu\text{s}, T_J=25^{\circ}\text{C}$		26		ns
		$I_F=10\text{A}, V_R=30\text{V}, dI_F/dt=-200\text{A}/\mu\text{s}, T_J=25^{\circ}\text{C}$		52		ns

Notes: 1. Pulse test: $t_P = 380\text{ ms}$, $\delta = 2\%$.

2. Pulse test: $t_P = 5\text{ ms}$, $\delta = 2\%$.

3. To evaluate the conduction losses use the following equation: $P=1.4 \times I_{F(AV)} + 0.027 I_F^2$ (RMS).

■ TYPICAL CHARACTERISTICS

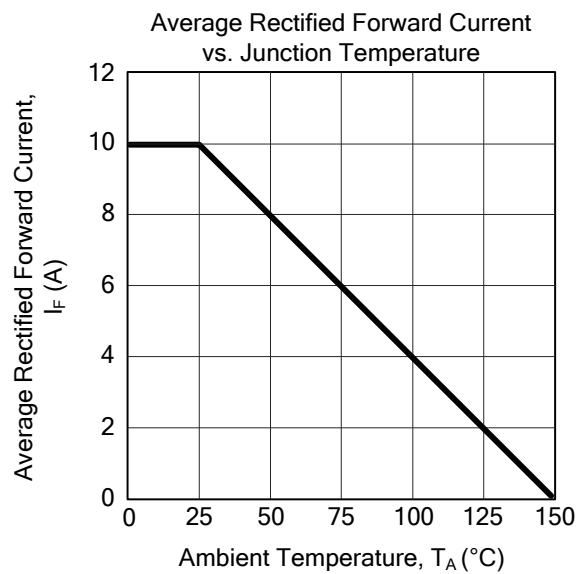
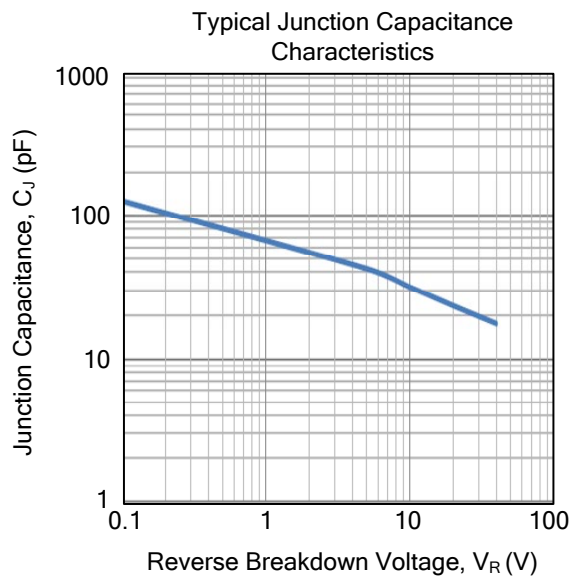
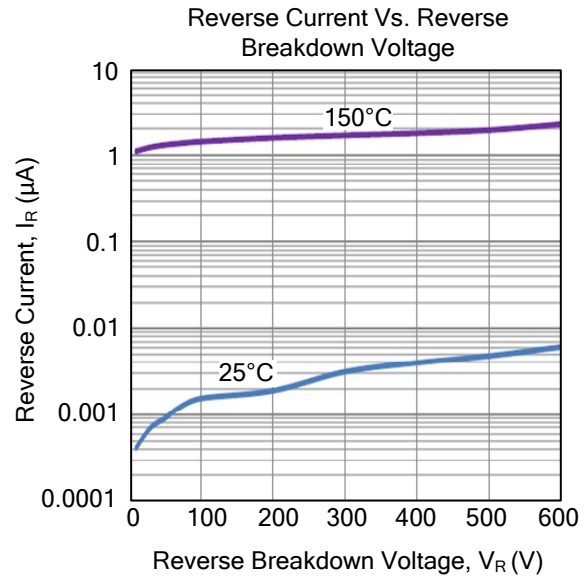
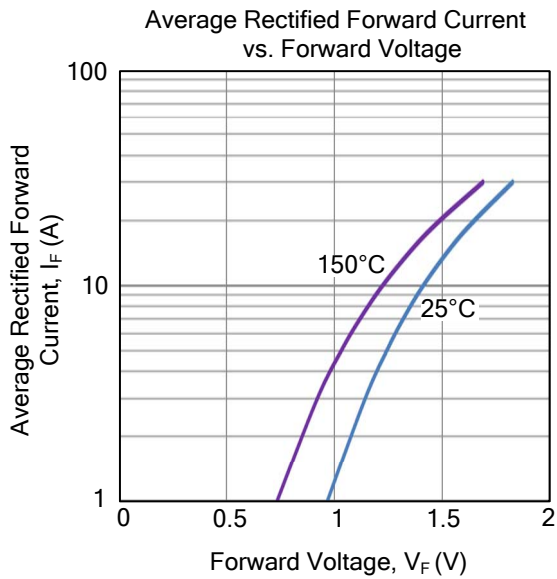

UTC assumes no responsibility for equipment failures that result from using products at values that exceed, even momentarily, rated values (such as maximum ratings, operating condition ranges, or other parameters) listed in products specifications of any and all UTC products described or contained herein. UTC products are not designed for use in life support appliances, devices or systems where malfunction of these products can be reasonably expected to result in personal injury. Reproduction in whole or in part is prohibited without the prior written consent of the copyright owner. UTC reserves the right to make changes to information published in this document, including without limitation specifications and product descriptions, at any time and without notice. This document supersedes and replaces all information supplied prior to the publication hereof.