



USSP8021

Preliminary

PNP EPITAXIAL SILICON TRANSISTOR

-21V, -8.0A PNP LOW $V_{CE(SAT)}$ TRANSISTOR

■ **FEATURES**

- * Low collector-emitter saturation voltage $V_{CE(SAT)}$
- * High collector current capability: I_C and I_{CM}
- * Higher efficiency leading to less heat generation
- * Reduced printed-circuit board requirements
- * Complement: USSN8021

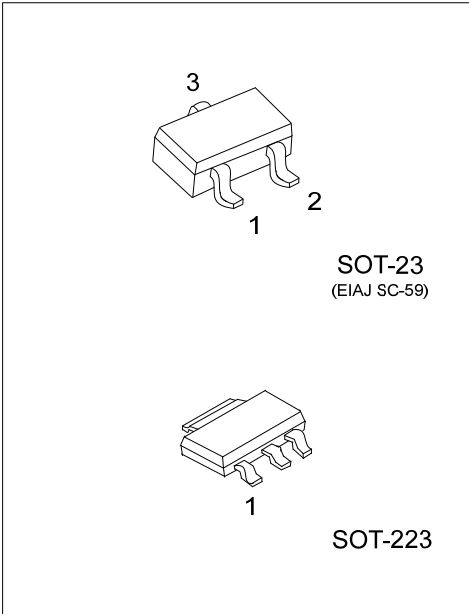

■ **ORDERING INFORMATION**

Ordering Number		Package	Pin Assignment			Packing
Lead Free	Halogen Free		1	2	3	
USSP8021L-AA3-R	USSP8021G-AA3-R	SOT-223	B	C	E	Tape Reel
USSP8021L-AE3-R	USSP8021G-AE3-R	SOT-23	B	E	C	Tape Reel

Note: Pin Assignment: B: Base C: Collector E: Emitter

<p>USSP8021G-AA3-R</p>	<p>(1) R: Tape Reel</p> <p>(2) AA3: SOT-223, AE3: SOT-23</p> <p>(3) G: Halogen Free and Lead Free, L: Lead Free</p>
------------------------	---

■ **MARKING**

SOT-223	SOT-23

■ ABSOLUTE MAXIMUM RATING (T_A=25°C, unless otherwise specified)

PARAMETER		SYMBOL	RATINGS	UNIT
Collector-Base Voltage		V _{CB0}	-21	V
Collector-Emitter Voltage		V _{CEO}	-21	V
Emitter-Base Voltage		V _{EBO}	-5	V
Collector Current	DC	I _C	-8	A
	Peak	I _{CM}	-16	A
Power Dissipation (T _A ≤ 25°C)	SOT-223	P _D	1	W
	SOT-23		0.35	W
Junction Temperature		T _J	+150	°C
Storage Temperature		T _{STG}	-65 ~ +150	°C

Notes: 1. Absolute maximum ratings are those values beyond which the device could be permanently damaged. Absolute maximum ratings are stress ratings only and functional device operation is not implied.

2. Device mounted on a FR4 printed-circuit board, single-sided copper; tin-plated, mounting pad for collector 1 cm².

■ THERMAL DATA

PARAMETER		SYMBOL	RATINGS	UNIT
Junction to Ambient	SOT-223	θ _{JA}	125	°C/W
	SOT-23		357	°C/W
Junction to Case	SOT-223	θ _{JC}	10	°C/W
	SOT-23		90	°C/W

Note: Device mounted on a FR4 printed-circuit board, single-sided copper; tin-plated, mounting pad for collector 1 cm².

■ ELECTRICAL CHARACTERISTICS (T_A=25°C, unless otherwise specified)

PARAMETER	SYMBOL	TEST CONDITIONS	MIN	TYP	MAX	UNIT
Collector to Base Breakdown Voltage	BV _{CB0}	I _C =-100μA, I _E =0	-21			V
Collector to Emitter Breakdown Voltage	BV _{CEO}	I _C =-1mA, I _B =0	-21			V
Emitter to Base Breakdown Voltage	BV _{EBO}	I _E =-100μA, I _C =0	-8			V
Collector Cut-Off Current	I _{CBO}	V _{CB} =-20V, I _E =0			-100	nA
		V _{CB} =-20V, I _E =0, T _J =150°C			-50	μA
Collector Cut-Off Current	I _{CES}	V _{CE} =-10V, V _{BE} =0			-100	nA
Emitter Cut-Off Current	I _{EBO}	V _{EB} =-5V, I _C =0			-100	nA
Collector-Emitter Saturation Voltage (Note)	V _{CE(SAT)}	I _C =-1A, I _B =-50mA			-60	mV
		I _C =-1A, I _B =-10mA			-120	mV
		I _C =-2A, I _B =-40mA			-150	mV
		I _C =-4A, I _B =-200mA			-220	mV
		I _C =-7A, I _B =-350mA			-350	mV
		I _C =-8A, I _B =-800mA			-600	mV
Base-Emitter Saturation Voltage (Note)	V _{BE(SAT)}	I _C =-1A, I _B =-400mA			-0.9	V
		I _C =-6A, I _B =-600mA			-1.2	V
		I _C =-8A, I _B =-800mA			-1.3	V
Base-Emitter Turn-On Voltage (Note)	V _{BE(ON)}	V _{CE} =-2V, I _C =-2A			-1	V
Dc Current Gain (Note)	h _{FE}	V _{CE} =-2V, I _C =-500mA	230			
		V _{CE} =-2V, I _C =-1.0A	300			
		V _{CE} =-2V, I _C =-2.0A	300			
		V _{CE} =-2V, I _C =-4.0A	250			
		V _{CE} =-2V, I _C =-6.0A	230			
		V _{CE} =-2V, I _C =-8.0A	200			
Transition Frequency	f _T	I _C =-100mA, V _{CE} =-10V, f=100MHz	50			MHz

Note: Pulse test: t_p ≤ 300μs, Duty cycle ≤ 2%.

UTC assumes no responsibility for equipment failures that result from using products at values that exceed, even momentarily, rated values (such as maximum ratings, operating condition ranges, or other parameters) listed in products specifications of any and all UTC products described or contained herein. UTC products are not designed for use in life support appliances, devices or systems where malfunction of these products can be reasonably expected to result in personal injury. Reproduction in whole or in part is prohibited without the prior written consent of the copyright owner. UTC reserves the right to make changes to information published in this document, including without limitation specifications and product descriptions, at any time and without notice. This document supersedes and replaces all information supplied prior to the publication hereof.