



# USC065R260B

Power MOSFET

## 15.5A, 650V N-CHANNEL SILICON CARBIDE PLANAR ENHANCEMENT POWER MOSFET

### DESCRIPTION

SiC The material can achieve high voltage with most carrier devices (MOSFET) with fast device structure characteristics, so it can realize the three characteristics of "high voltage", "low on resistance" and "high frequency" at the same time.

It is widely used in electric vehicle charger, industrial equipment power supply, efficient power regulator inverter and rectification part and other uses.

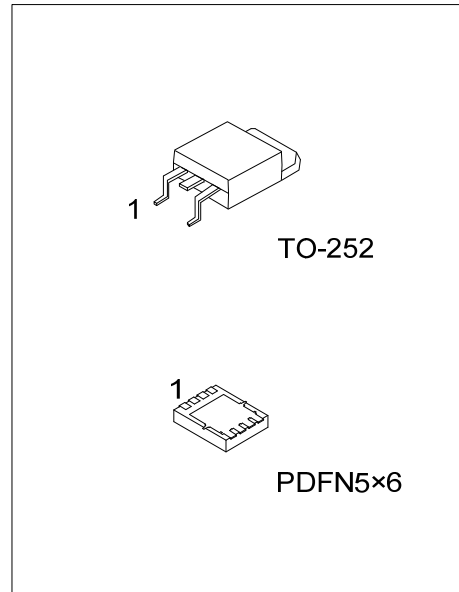

### FEATURES

- \*  $R_{DS(ON)} \leq 300 \text{ m}\Omega @ V_{GS}=15\text{V}, I_D=5.0\text{A}$
- \* Wide bandgap SiC MOSFET technology
- \* High Blocking Voltage with Low On-Resistance
- \* High Speed Switching with Low Capacitances
- \* High-Speed And High Robust Intrinsic Body Diode

### SYMBOL

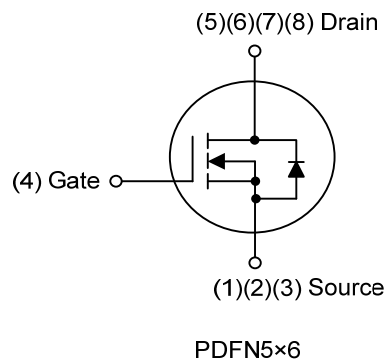
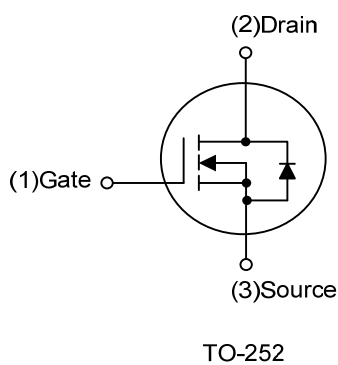

# USC065R260B

**Power MOSFET**

## ORDERING INFORMATION

Ordering Number		Package	Pin Assignment								Packing
Lead Free	Halogen Free		1	2	3	4	5	6	7	8	
USC065R260BL-TN3-R	USC065R260BG-TN3-R	TO-252	G	D	S	-	-	-	-	-	Tape Reel
USC065R260BL-P5060-R	USC065R260BG-P5060-R	PDFN5x6	S	S	S	G	D	D	D	D	Tape Reel

Note: Pin Assignment: G: Gate D: Drain S: Source

<p>USC065R260BG-TN3-R</p> <p>(1) Packing Type (2) Package Type (3) Green Package</p>	<p>(1) R: Tape Reel (2) TN3: TO-252, P5060: PDFN5x6 (3) G: Halogen Free and Lead Free, L: Lead Free</p>
--	---

## MARKING

TO-252	PDFN5x6
<p>UTC USC 065R260B □ □□□□□□ Lot Code ← → Date Code L: Lead Free G: Halogen Free 1</p>	<p>UTC USC 065R260B • □□□□□□ Lot Code ← → Date Code</p>

■ ABSOLUTE MAXIMUM RATINGS (T<sub>c</sub>=25°C, unless otherwise specified)

PARAMETER		SYMBOL	RATINGS	UNIT
Drain-Source Voltage		V <sub>DSS</sub>	650	V
Gate-Source Voltage	Dynamic	V <sub>GSS</sub>	-10 / +22	V
	Static		0 / +15	V
Drain Current	Continuous	T <sub>c</sub> =25°C	15.5	A
		T <sub>c</sub> =100°C	11	A
	Pulsed (Note 2)	I <sub>DM</sub>	25	A
Power Dissipation	TO-252	P <sub>D</sub>	67	W
	PDFN5×6		90	W
Junction Temperature		T <sub>J</sub>	-55 ~ +175	°C
Storage Temperature		T <sub>STG</sub>	-55 ~ +175	°C

Notes: 1. Absolute maximum ratings are those values beyond which the device could be permanently damaged.

Absolute maximum ratings are stress ratings only and functional device operation is not implied.

2. Repetitive Rating: Pulse width limited by maximum junction temperature.

■ THERMAL DATA

PARAMETER		SYMBOL	RATINGS	UNIT
Junction to Case	TO-252	θ <sub>JC</sub>	2.23	°C/W
	PDFN5×6		1.67	°C/W

Notes: 1. The maximum current rating is package limited.

2. Pulse Test Pulse Width ≤ 10ms, Duty Cycle ≤ 1%.

■ ELECTRICAL CHARACTERISTICS (T<sub>J</sub>=25°C, unless otherwise specified)

PARAMETER	SYMBOL	TEST CONDITIONS	MIN	TYP	MAX	UNIT
<b>OFF CHARACTERISTICS</b>						
Drain-Source Breakdown Voltage	B <sub>VDS</sub>	I <sub>D</sub> =100μA, V <sub>GS</sub> =0V	650			V
Zero Gate Voltage Drain Current	I <sub>DSS</sub>	V <sub>DS</sub> =650V, V <sub>GS</sub> =0V		0.1	20	μA
Gate- Source Leakage Current	I <sub>GSS</sub>	V <sub>GS</sub> =-10/+22V, V <sub>DS</sub> =0V			±250	nA
<b>ON CHARACTERISTICS</b>						
Gate Threshold Voltage	V <sub>GS(TH)</sub>	V <sub>DS</sub> =V <sub>GS</sub> , I <sub>D</sub> =10mA	3.2	4.1	5.0	V
		V <sub>DS</sub> =V <sub>GS</sub> , I <sub>D</sub> =10mA, T <sub>J</sub> =175°C		2.9		V
Static Drain-Source On-State Resistance	R <sub>DS(ON)</sub>	V <sub>GS</sub> =15V, I <sub>D</sub> =5.0A		260	300	mΩ
		V <sub>GS</sub> =15V, I <sub>D</sub> =5.0A, T <sub>J</sub> =175°C		231		mΩ
Transconductance	g <sub>FS</sub>	V <sub>DS</sub> =20V, I <sub>D</sub> =5.0A		3.6		S
<b>DYNAMIC PARAMETERS</b>						
Input Capacitance	C <sub>ISS</sub>	V <sub>DS</sub> =650V, V <sub>GS</sub> =0V, f=1MHz		294		pF
Output Capacitance	C <sub>OSS</sub>			25		pF
Reverse Transfer Capacitance	C <sub>RSS</sub>			4		pF
<b>SWITCHING PARAMETERS</b>						
Total Gate Charge	Q <sub>G</sub>	V <sub>DS</sub> =400V, V <sub>GS</sub> =0V / +15V, I <sub>D</sub> =5.0A		4.3		nC
Gate to Source Charge	Q <sub>GS</sub>			1.6		nC
Gate to Drain Charge	Q <sub>GD</sub>			12.5		nC
Internal Gate Input Resistance	R <sub>G</sub>	V <sub>AC</sub> =25mV, f=1MHz		25.5		Ω
Turn-on switching energy	E <sub>ON</sub>	V <sub>DS</sub> =400V, V <sub>GS</sub> =0V / +15V, I <sub>D</sub> =5.0A, R <sub>G</sub> =2.2Ω, L=600μH		43.2		μJ
Turn-off switching energy	E <sub>OFF</sub>			5.5		μJ
Turn-ON Delay Time	t <sub>D(ON)</sub>			6.6		ns
Rise Time	t <sub>r</sub>			18.3		ns
Turn-OFF Delay Time	t <sub>D(OFF)</sub>			17.7		ns
Fall-Time	t <sub>f</sub>			32.1		ns
<b>SOURCE- DRAIN DIODE RATINGS AND CHARACTERISTICS</b>						
Drain-Source Diode Forward Voltage	V <sub>SD</sub>	V <sub>GS</sub> =0V, I <sub>SD</sub> =2.5A, T <sub>J</sub> =25°C		3.3		V
		V <sub>GS</sub> =0V, I <sub>SD</sub> =2.5A, T <sub>J</sub> =175°C		2.8		V
Continuous Diode Forward Current	I <sub>S</sub>				12	A
Body Diode Reverse Recovery Time	t <sub>rr</sub>	V <sub>GS</sub> =0V, I <sub>F</sub> =5.0V, V <sub>R</sub> =400V, di <sub>F</sub> /dt=1600A/μs		9.9		ns
Body Diode Reverse Recovery Charge	Q <sub>rr</sub>			32.6		nC
Peak Reverse Recovery Current	I <sub>rrm</sub>			5.8		A

## TYPICAL CHARACTERISTICS

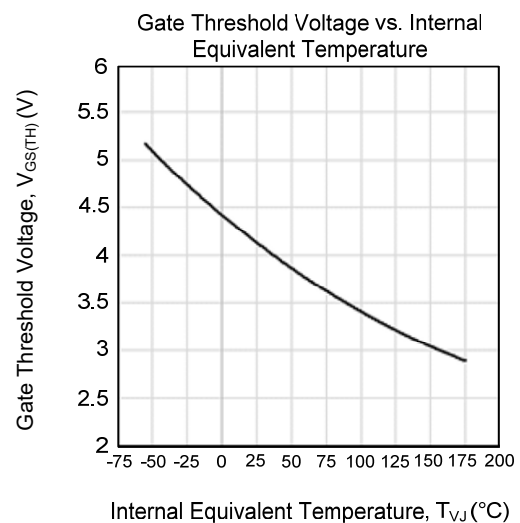
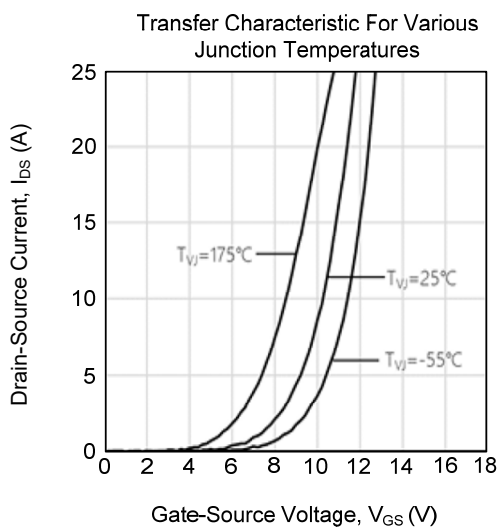
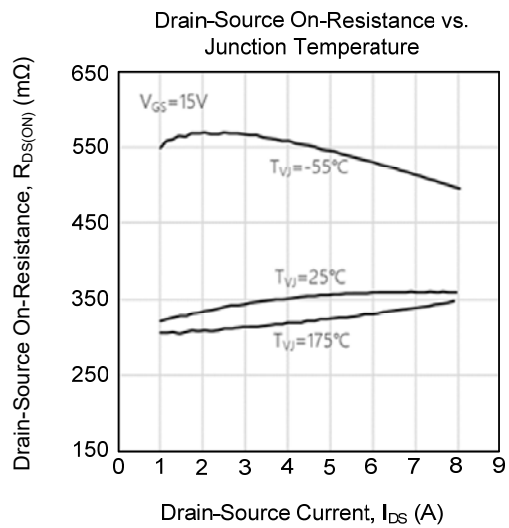
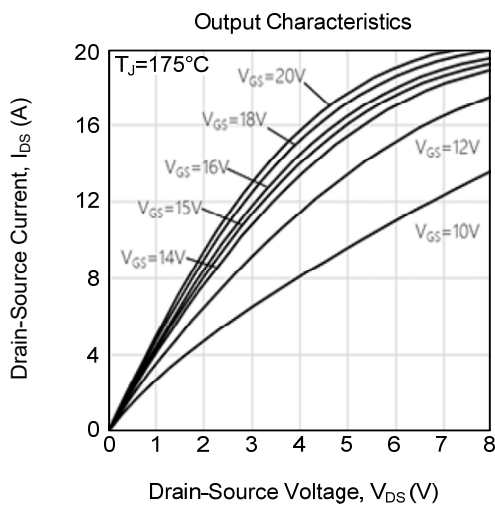
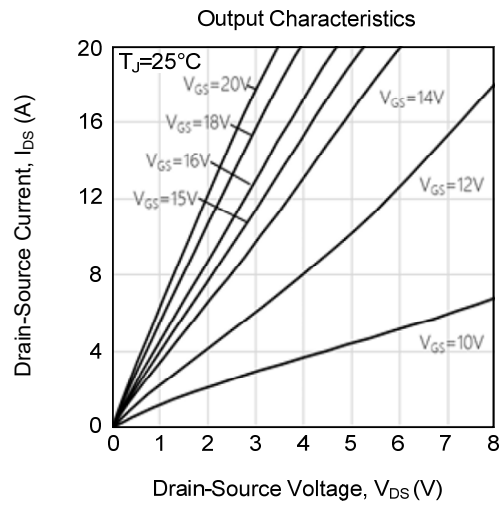
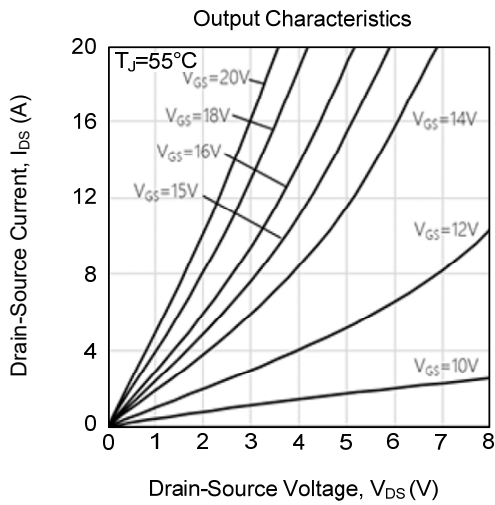

■ TYPICAL CHARACTERISTICS (Cont.)

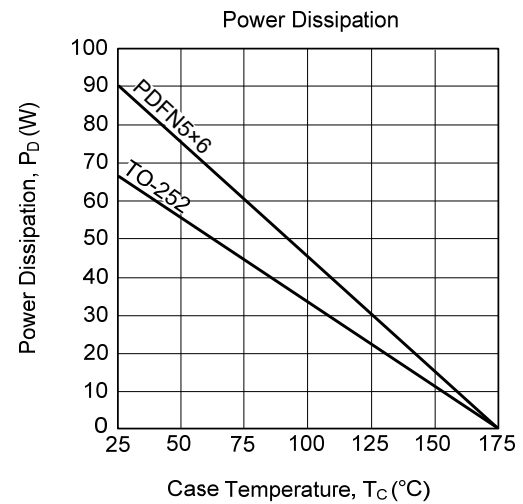
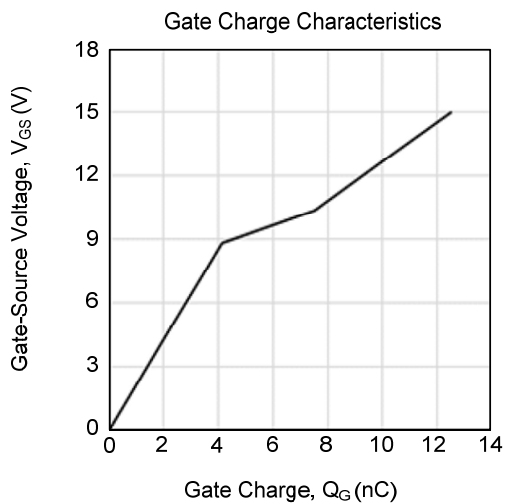
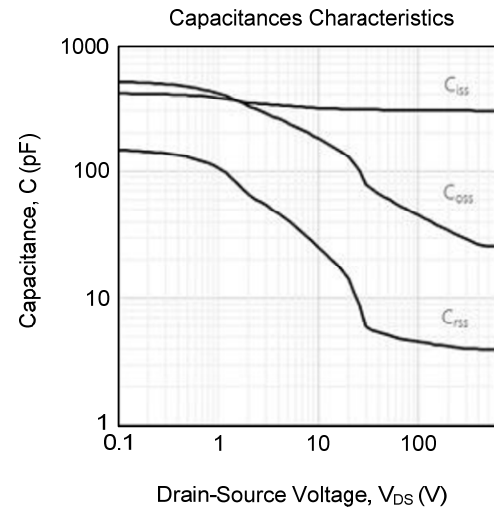
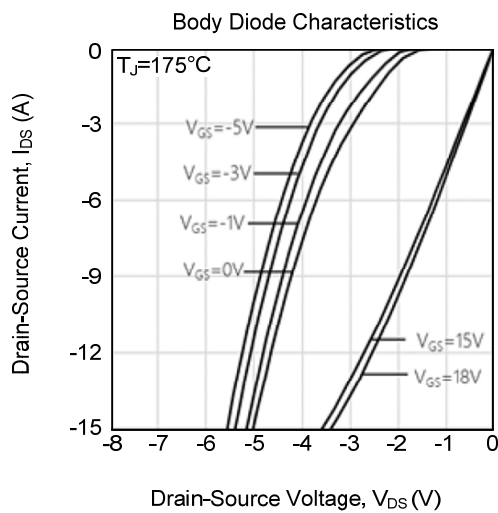
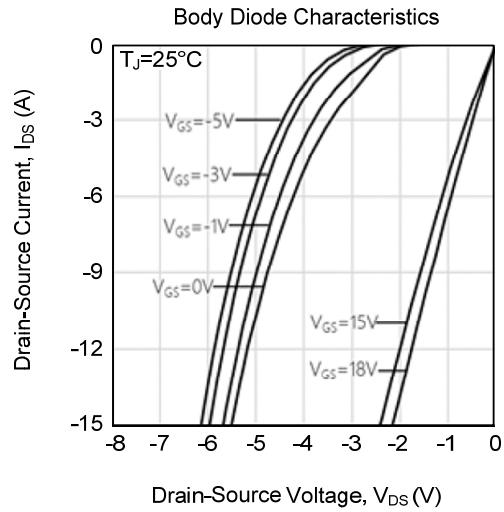
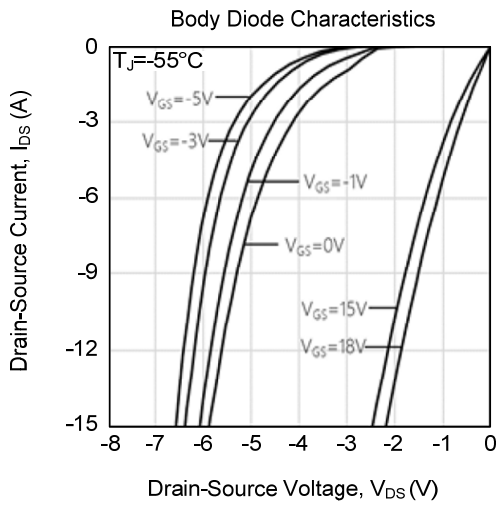

■ TYPICAL CHARACTERISTICS (Cont.)

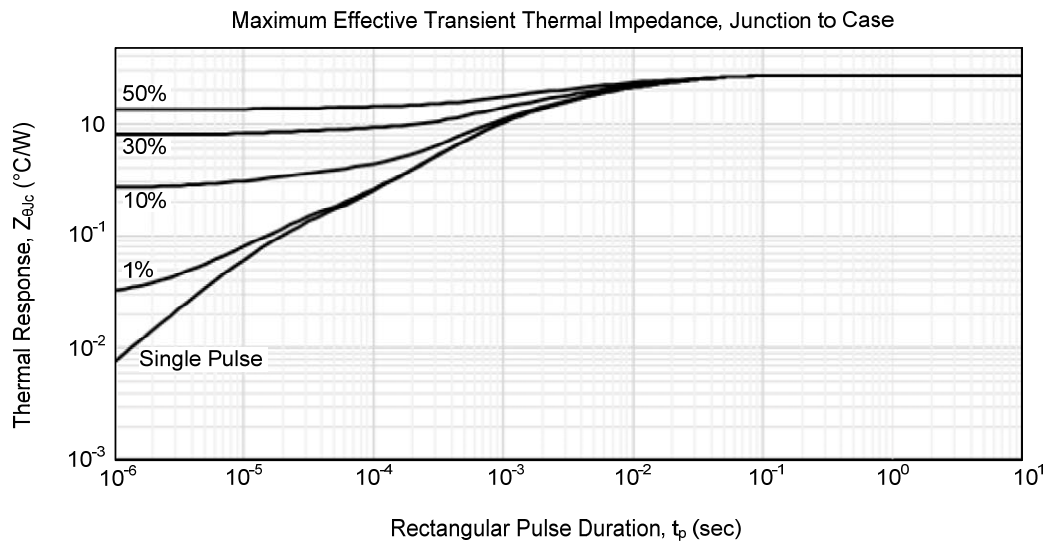

UTC assumes no responsibility for equipment failures that result from using products at values that exceed, even momentarily, rated values (such as maximum ratings, operating condition ranges, or other parameters) listed in products specifications of any and all UTC products described or contained herein. UTC products are not designed for use in life support appliances, devices or systems where malfunction of these products can be reasonably expected to result in personal injury. Reproduction in whole or in part is prohibited without the prior written consent of the copyright owner. UTC reserves the right to make changes to information published in this document, including without limitation specifications and product descriptions, at any time and without notice. This document supersedes and replaces all information supplied prior to the publication hereof.