



UPC215

Preliminary

PHOTOCOUPLER

SSOP-4 PHOTODARLINGTON PHOTOCOUPLER

DESCRIPTION

The UTC **UPC215** is a photodarlington photocoupler, it uses UTC's advanced technology to provide the customers with high isolation voltage between input and output, etc.

The UTC **UPC215** is suitable for programmable controllers and telecommunication equipments, etc.



FEATURES

- * Current transfer ratio (CTR: MIN. 200% at $I_F=1mA, V_{CE}=2V$)
- * Isolation voltage between input and output ($V_{ISO}=3750 Vrms$)
- * High collector-emitter voltage ($V_{CEO}=40V$)
- * Employs double transfer mold technology

SYMBOL

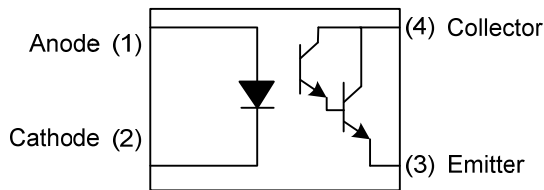

ORDERING INFORMATION

Ordering Number		Package	Pin Assignment				Packing
Lead Free	Halogen Free		1	2	3	4	
UPC215L-R04-R	UPC215G-R04-R	SSOP-4	A / K	K / A	E	C	Tape Reel
UPC215KL-R04-R	UPC215KG-R04-R	SSOP-4	A / K	K / A	E	C	Tape Reel

Note: Pin Assignment: A: Anode K: Cathode E: Emitter C: Collector

<p>UPC215KG-R04-R</p> <p>(1) Packing Type (2) Package Type (3) Green Package (4) Rank</p>	<p>(1) R: Tape Reel (2) R04: SSOP-4 (3) G: Halogen Free and Lead Free, L: Lead Free (4) Refer to TRANSFER CHARACTERISTICS</p>
---	---

MARKING

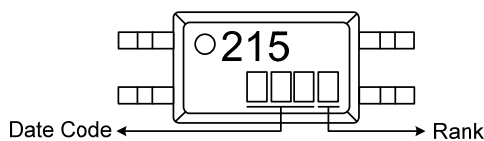

■ ABSOLUTE MAXIMUM RATING ($T_A=25^{\circ}\text{C}$, unless otherwise specified)

	PARAMETER	SYMBOL	RATINGS	UNIT
Input	Forward Current	I_F	50	mA
	Pulse Forward Current	I_{FP}	1	A
	Reverse Voltage	V_R	6	V
	Power Dissipation	P_D	60	mW
Output	Collector-Emitter Voltage	V_{CEO}	40	V
	Emitter-Collector Voltage	V_{ECO}	6	V
	Collector Current	I_C	90	mA
	Collector Power Dissipation	P_C	150	mW
Power Dissipation		P_D	170	mW
Junction Temperature		T_J	125	$^{\circ}\text{C}$
Isolation Voltage (Note 2)		V_{ISO}	3750	Vrms
Operating Temperature		T_{OPR}	-55 ~ +110	$^{\circ}\text{C}$
Storage Temperature		T_{STG}	-55 ~ +150	$^{\circ}\text{C}$

Notes: 1. Absolute maximum ratings are those values beyond which the device could be permanently damaged.

Absolute maximum ratings are stress ratings only and functional device operation is not implied.

2. AC for 1 minute, R.H. = 40~60%.

Isolation voltage shall be measured using the following method.

(1) Short between anode and cathode on the primary side and between collector and emitter on the secondary side.

(2) The isolation voltage tester with zero-cross circuit shall be used.

(3) The waveform of applied voltage shall be a sine wave.

■ ELECTRICAL CHARACTERISTICS ($T_A=25^{\circ}\text{C}$, unless otherwise specified)

PARAMETER	SYMBOL	TEST CONDITIONS	MIN	TYP	MAX	UNIT
INPUT						
Forward Voltage	V_F	$I_F=5\text{mA}$		1.1	1.4	V
Reverse Current	I_R	$V_R=5\text{V}$			10	μA
Terminal Capacitance	C_t	$V=0, f=1\text{KHz}$		30	250	pF
OUTPUT						
Collector-Emitter Dark Current	I_{CEO}	$V_{CE}=40\text{V}, I_F=0$			400	nA
Collector-Emitter Breakdown Voltage	BV_{CEO}	$I_C=0.1\text{mA}, I_F=0$	40			V
Emitter-Collector Breakdown Voltage	BV_{ECO}	$I_E=10\mu\text{A}, I_F=0$	6			V

■ TRANSFER CHARACTERISTICS ($T_A=25^{\circ}\text{C}$, unless otherwise specified)

PARAMETER	SYMBOL	TEST CONDITIONS	MIN	TYP	MAX	UNIT
Collector Current	I_C	$I_F=1\text{mA}, V_{CE}=2\text{V}$	2	20		mA
Current Transfer Ratio	CTR	$I_F=1\text{mA}, V_{CE}=2\text{V}$	UPC215	200		%
			UPC215K	2000		%
Collector-Emitter Saturation Voltage	$V_{CE(SAT)}$	$I_F=1\text{mA}, I_C=2\text{mA}$			1	V
Isolation Resistance	R_{IO}	$V_{IO}=500\text{Vdc}, 40\sim 60\% \text{ R.H.}$	5×10^{10}	1×10^{11}		Ω
Floating Capacitance	C_{IO}	$V=0, f=1\text{MHz}$		0.6	1	pF
Rise Time	t_R	$V_{CE}=5\text{V}, I_C=2\text{mA}, R_L=100\Omega$		200		μs
Fall Time	t_F			200		μs

■ TEST CIRCUITS AND WAVEFORMS

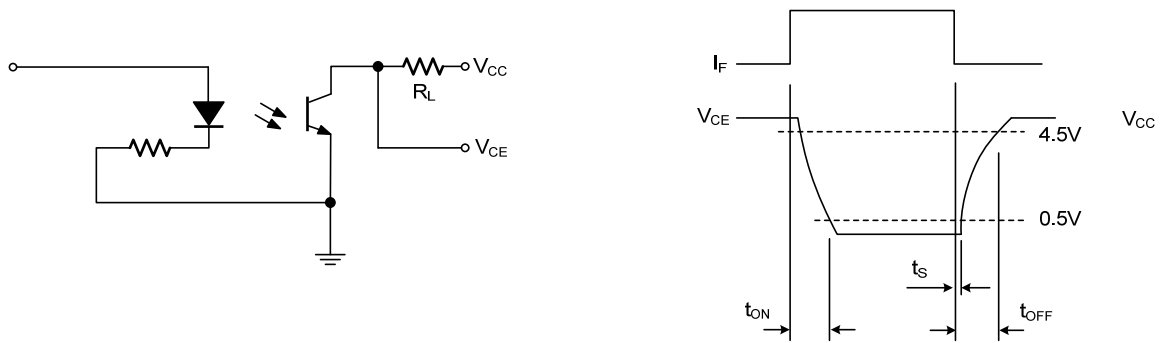

Test Circuit for Response Time

UTC assumes no responsibility for equipment failures that result from using products at values that exceed, even momentarily, rated values (such as maximum ratings, operating condition ranges, or other parameters) listed in products specifications of any and all UTC products described or contained herein. UTC products are not designed for use in life support appliances, devices or systems where malfunction of these products can be reasonably expected to result in personal injury. Reproduction in whole or in part is prohibited without the prior written consent of the copyright owner. UTC reserves the right to make changes to information published in this document, including without limitation specifications and product descriptions, at any time and without notice. This document supersedes and replaces all information supplied prior to the publication hereof.