



UMD9

DUAL TRANSISTOR

DUAL DIGITAL TRANSISTOR (BUILT-IN BIAS RESISTORS)

■ DESCRIPTION

The UTC **UMD9** is an dual transistor; it uses UTC's advanced technology to provide the customers with low collector -emitter saturation voltage, etc.

■ FEATURES

- * NPN/PNP silicon transistor(Built-in resistor type)
- * Low collector-emitter saturation voltage
- * With built-in bias resistors
- * Simplify circuit design

■ EQUIVALENT CIRCUIT

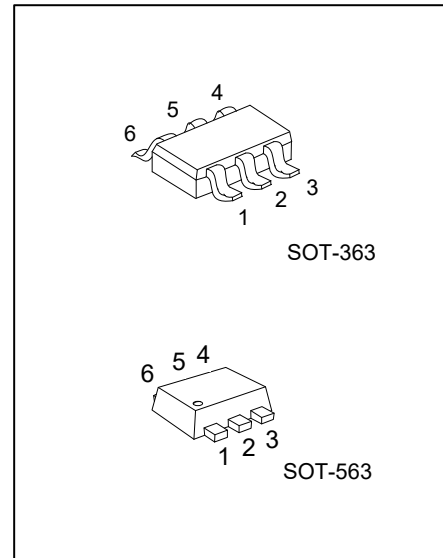
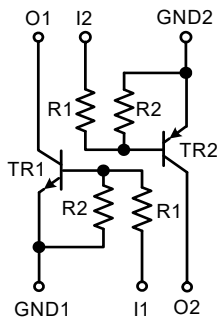

■ ORDERING INFORMATION

Ordering Number		Package	Pin Assignment						Packing
Lead Free	Halogen Free		1	2	3	4	5	6	
UMD9L-AL6-R	UMD9G-AL6-R	SOT-363	G1	I1	O2	G2	I2	O1	Tape Reel
UMD9L-AN6-R	UMD9G-AN6-R	SOT-563	G1	I1	O2	G2	I2	O1	Tape Reel

Note: Pin Assignment: G: GND I: IN O: OUT

<p>UMD9G-AL6-R</p> <ul style="list-style-type: none"> (1)Packing Type (2)Package Type (3)Green Package 	<ul style="list-style-type: none"> (1) R: Tape Reel (2) AL6: SOT-363, AN6: SOT-563 (3) G: Halogen Free and Lead Free, L: Lead Free
---	---

■ MARKING

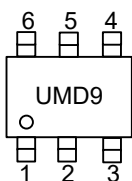

■ ABSOLUTE MAXIMUM RATING (T_A=25°C, unless otherwise specified)

PARAMETER		SYMBOL	RATINGS		UNIT
			TR1 (NPN)	TR2 (PNP)	
Collector-Base Voltage		V _{CBO}	50	-50	V
Collector-Emitter Voltage		V _{CEO}	50	-50	V
Emitter-Base Voltage		V _{EBO}	6	-6	V
Input Voltage		V _{IN}	-6 ~ +40	-40 ~ +6	V
Output Current		I _{OUT}	100	-100	mA
Power Dissipation	SOT-363	P _C	300		mW
	SOT-563		250		mW
Junction Temperature		T _J	+150		°C
Ambient Temperature		T _A	-55 ~ +150		°C
Storage Temperature		T _{STG}	-55 ~ +150		°C

Note: Absolute maximum ratings are those values beyond which the device could be permanently damaged. Absolute maximum ratings are stress ratings only and functional device operation is not implied.

■ THERMAL DATA

PARAMETER		SYMBOL	RATINGS	UNIT
Junction to Ambient	SOT-363	θ _{JA}	417 (Note)	°C/W
	SOT-563		500 (Note)	°C/W

Note: Device mounted on FR-4 substrate PC board, 2oz copper, with 1inch square copper plate.

■ ELECTRICAL CHARACTERISTICS (T_A=25°C, unless otherwise specified)

TR1 (NPN)

PARAMETER	SYMBOL	TEST CONDITIONS	MIN	TYP	MAX	UNIT
Collector-Base Breakdown Voltage	V _{(BR)CBO}	I _C =100μA, I _E =0A	50			V
Collector-Emitter Breakdown Voltage	V _{(BR)CEO}	I _C =2mA, I _B =0A	50			V
Collector-Base Cut-Off Current	I _{CBO}	V _{CB} =50V, I _E =0A			100	nA
Collector-Emitter Cut-Off Current	I _{CEO}	V _{CE} =30V, I _B =0A			1	μA
Emitter-Base Cut-Off Current	I _{EBO}	V _{EB} =5V, I _C =0A			150	μA
DC Current Gain	h _{FE}	V _{CE} =5V, I _C =5mA	100			
Collector-Emitter Saturation Voltage	V _{CE(SAT)}	I _C =5mA, I _B =0.25mA			100	mV
Off-State Input Voltage	V _{I(OFF)}	V _{CE} =5V, I _C =100μA			0.8	V
On-State Input Voltage	V _{I(ON)}	V _{CE} =0.3V, I _C =10mA	3			V
Bias Resistor 1 (Input)	R1		7	10	13	KΩ
Bias Resistor Ratio	R2/R1		3.7	4.7	5.7	
Transition Frequency	f _T	V _{CE} =5V, I _C =10mA, f=100MHz		230		MHz

Note: Transition frequency of the device.

■ ELECTRICAL CHARACTERISTICS (Cont.)

TR2 (PNP)

PARAMETER	SYMBOL	TEST CONDITIONS	MIN	TYP	MAX	UNIT
Collector-Base Breakdown Voltage	$V_{(BR)CBO}$	$I_C=-100\mu A, I_E=0A$	-50			V
Collector-Emitter Breakdown Voltage	$V_{(BR)CEO}$	$I_C=-2mA, I_B=0A$	-50			V
Collector-Base Cut-Off Current	I_{CBO}	$V_{CB}=-50V, I_E=0A$			-100	nA
Collector-Emitter Cut-Off Current	I_{CEO}	$V_{CE}=-30V, I_B=0A$			-1	μA
Emitter-Base Cut-Off Current	I_{EBO}	$V_{EB}=-5V, I_C=0A$			-150	μA
DC Current Gain	h_{FE}	$V_{CE}=-5V, I_C=-5mA$	100			
Collector-Emitter Saturation Voltage	$V_{CE(SAT)}$	$I_C=-5mA, I_B=-0.25mA$			-100	mV
Off-State Input Voltage	$V_{I(OFF)}$	$V_{CE}=-5V, I_C=-100\mu A$			-0.8	V
On-State Input Voltage	$V_{I(ON)}$	$V_{CE}=-0.3V, I_C=-10mA$	-3			V
Bias Resistor 1 (Input)	R1		7	10	13	K Ω
Bias Resistor Ratio	R2/R1		3.7	4.7	5.7	
Transition Frequency	f_T	$V_{CE}=-5V, I_C=-10mA, f=100MHz$		180		MHz

Note: Transition frequency of the device.

■ TYPICAL CHARACTERISTICS

TR1 (NPN)

Input Voltage vs. Output Current
(ON Characteristics)

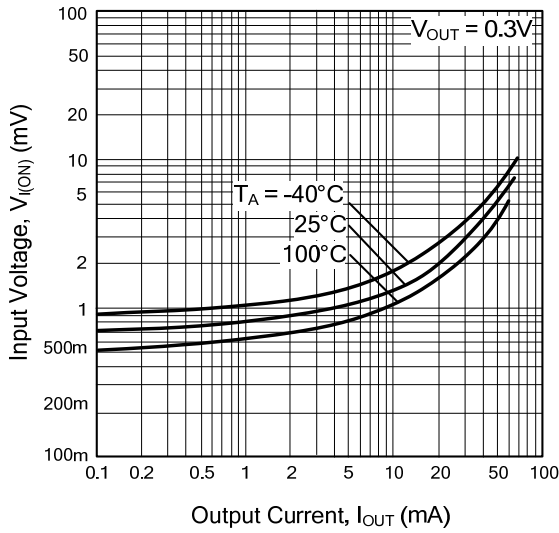

Output Current vs. Input Voltage
(OFF Characteristics)

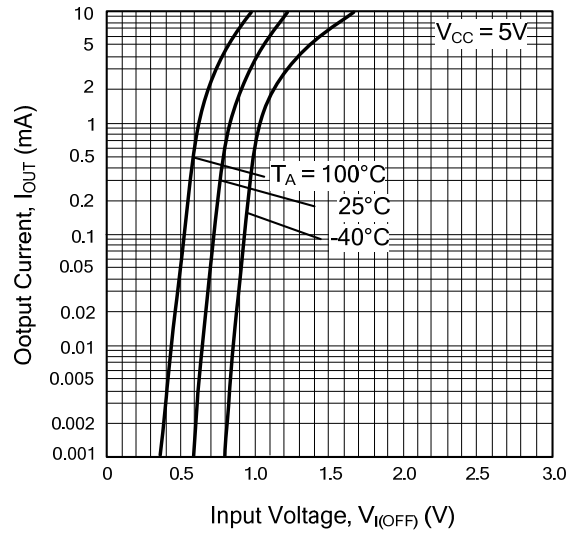

DC Current Gain vs. Output Current

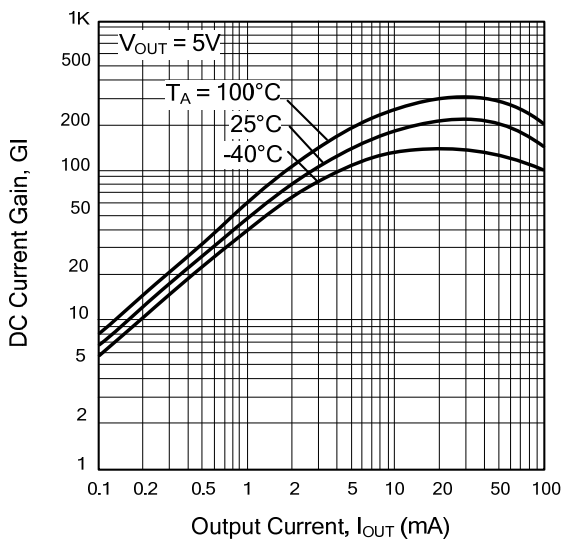

Output Voltage vs. Output Current

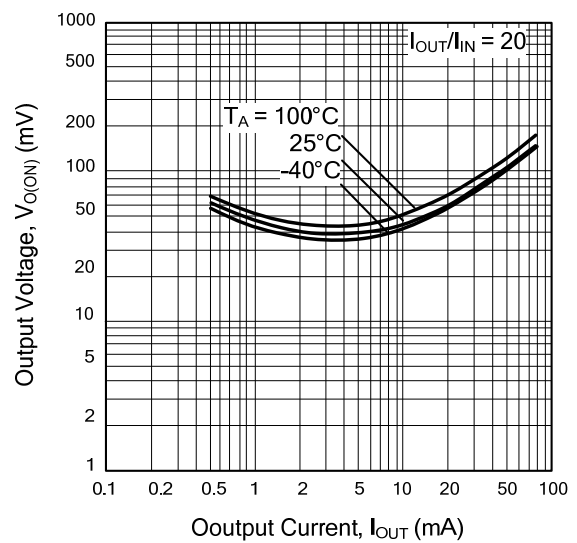

■ TYPICAL CHARACTERISTICS (Cont.)

TR2 (PNP)

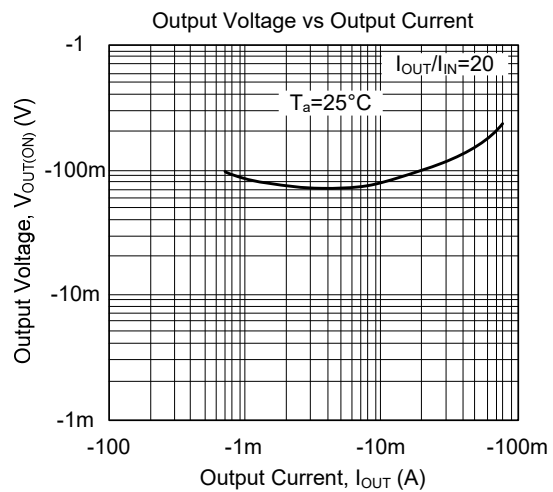
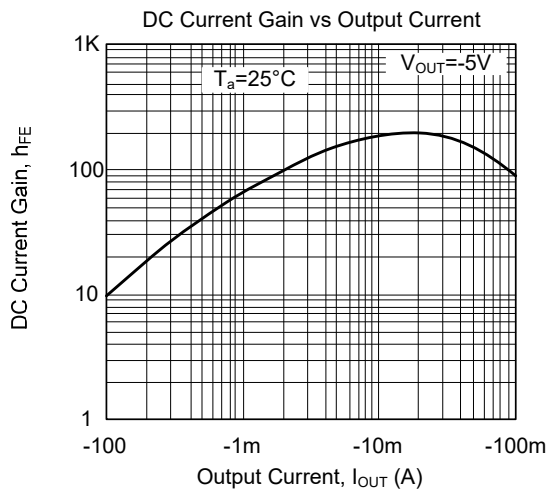
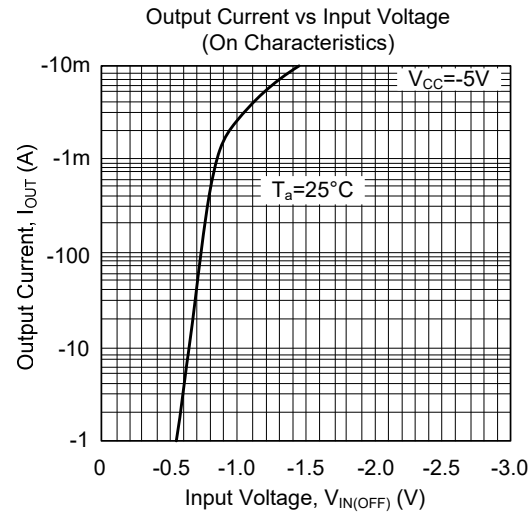
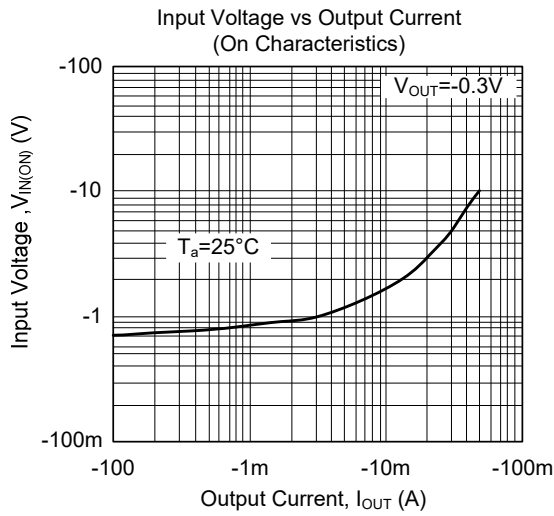

UTC assumes no responsibility for equipment failures that result from using products at values that exceed, even momentarily, rated values (such as maximum ratings, operating condition ranges, or other parameters) listed in products specifications of any and all UTC products described or contained herein. UTC products are not designed for use in life support appliances, devices or systems where malfunction of these products can be reasonably expected to result in personal injury. Reproduction in whole or in part is prohibited without the prior written consent of the copyright owner. UTC reserves the right to make changes to information published in this document, including without limitation specifications and product descriptions, at any time and without notice. This document supersedes and replaces all information supplied prior to the publication hereof.