



UT110P06M

Power MOSFET

-110A, -60V P-CHANNEL POWER MOSFET

DESCRIPTION

The UTC **UT110P06M** provide excellent $R_{DS(ON)}$, low gate charge and operation with low gate voltages. This device is suitable for use as a load switch or in PWM applications.

FEATURES

- * $R_{DS(ON)} \leq 7.5 \text{ m}\Omega @ V_{GS} = -10\text{V}, I_D = -55\text{A}$
- * $R_{DS(ON)} \leq 14 \text{ m}\Omega @ V_{GS} = -4.5\text{V}, I_D = -55\text{A}$
- * High Switching Speed
- * 100% Avalanche Tested

SYMBOL

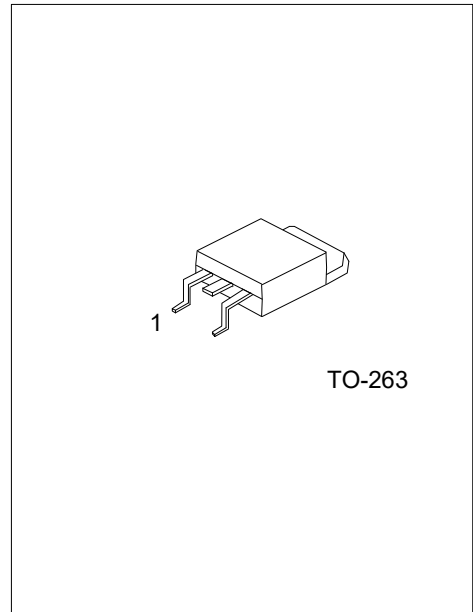
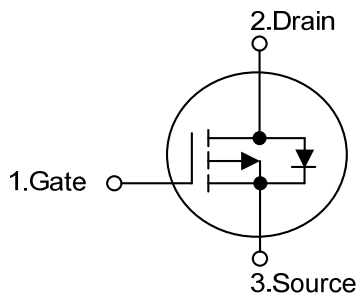

ORDERING INFORMATION

Ordering Number		Package	Pin Assignment			Packing
Lead Free	Halogen Free		1	2	3	
UT110P06ML-TQ2-T	UT110P06MG-TQ2-T	TO-263	G	D	S	Tube
UT110P06ML-TQ2-R	UT110P06MG-TQ2-R	TO-263	G	D	S	Tape Reel

Note: Pin Assignment: G: Gate D: Drain S: Source

<p>UT110P06MG-TQ2-T</p> <p>(1) Packing Type (2) Package Type (3) Green Package</p>	<p>(1) R: Tape Reel (2) TQ2: TO-263 (3) G: Halogen Free and Lead Free, L: Lead Free</p>
--	---

MARKING

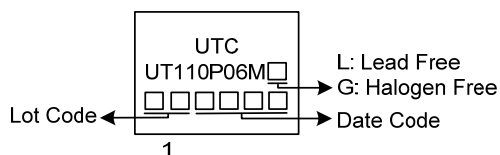

■ ABSOLUTE MAXIMUM RATINGS ($T_c=25^\circ\text{C}$, unless otherwise specified)

PARAMETER		SYMBOL	RATINGS	UNIT
Drain-Source Voltage		V_{DSS}	-60	V
Gate-Source Voltage		V_{GSS}	± 20	V
Drain Current	Continuous,	I_D	-110	A
	Pulsed (Note 2)	I_{DM}	-220	A
Avalanche Energy	Repetitive (Note 3)	E_{AS}	218	mJ
Peak Diode Recovery dv/dt (Note 4)		dv/dt	6.9	V/ns
Power Dissipation ($T_c=25^\circ\text{C}$)		P_D	215	W
Junction Temperature		T_J	+150	$^\circ\text{C}$
Storage Temperature		T_{STG}	-55 ~ +150	$^\circ\text{C}$

Notes: 1. Absolute maximum ratings are those values beyond which the device could be permanently damaged.

Absolute maximum ratings are stress ratings only and functional device operation is not implied.

2. Repetitive Rating: Pulse width limited by maximum junction temperature.

3. $L = 0.1\text{mH}$, $I_{AS} = -66\text{A}$, $V_{DD} = -50\text{V}$, $R_G = 25\Omega$, Starting $T_J = 25^\circ\text{C}$

4. $I_{SD} \leq -30\text{A}$, $di/dt \leq 200\text{A}/\mu\text{s}$, $V_{DD} \leq BV_{DSS}$, Starting $T_J = 25^\circ\text{C}$

■ THERMAL DATA

PARAMETER	SYMBOL	RATINGS	UNIT
Junction to Ambient	θ_{JA}	62.5	$^\circ\text{C}/\text{W}$
Junction to Case	θ_{JC}	0.58 (Note)	$^\circ\text{C}/\text{W}$

Note: Device mounted on FR-4 substrate P_c board, 2oz copper, with 1inch square copper plate.

■ ELECTRICAL CHARACTERISTICS (T_J=25°C, unless otherwise specified)

PARAMETER	SYMBOL	TEST CONDITIONS	MIN	TYP	MAX	UNIT
OFF CHARACTERISTICS						
Drain-Source Breakdown Voltage	BV _{DSS}	I _D =-250μA, V _{GS} =0V	-60			V
Drain-Source Leakage Current	I _{DSS}	V _{DS} =-60V, V _{GS} =0V			-1	μA
Gate- Source Leakage Current	Forward	I _{GSS}			+100	nA
	Reverse					
ON CHARACTERISTICS						
Gate Threshold Voltage	V _{GS(TH)}	V _{DS} =V _{GS} , I _D =-250μA	-1.0		-3.0	V
Static Drain-Source On-State Resistance	R _{DS(ON)}	V _{GS} =-10V, I _D =-55A			7.5	mΩ
		V _{GS} = -4.5V, I _D =-55A			14	mΩ
DYNAMIC PARAMETERS						
Input Capacitance	C _{ISS}	V _{DS} =-25V, V _{GS} =0V, f=1MHz		12		nF
Output Capacitance	C _{OSS}			1015		pF
Reverse Transfer Capacitance	C _{RSS}			776		pF
SWITCHING PARAMETERS						
Total Gate Charge (Note 1)	Q _G	V _{DS} =-48V, V _{GS} =-10V, I _D =-110A (Note 1, 2)		235		nC
Gate to Source Charge	Q _{GS}			66		nC
Gate to Drain Charge	Q _{GD}			42		nC
Turn-ON Delay Time (Note 1)	t _{D(ON)}	V _{DD} =-30V, I _D =-110A, R _G =3.3Ω (Note 1, 2)		30		ns
Rise Time	t _R			29		ns
Turn-OFF Delay Time	t _{D(OFF)}			150		ns
Fall-Time	t _F			79		ns
SOURCE- DRAIN DIODE RATINGS AND CHARACTERISTICS						
Maximum Body-Diode Continuous Current	I _S				-110	A
Maximum Body-Diode Pulsed Current	I _{SM}	(Note 1)			-220	A
Drain-Source Diode Forward Voltage	V _{SD}	I _S =-110A, V _{GS} =0V (Note 2)			-1.4	V
Body Diode Reverse Recovery Time (Note 1)	t _{rr}	I _S =-30A, V _{GS} =0V,		120		ns
Body Diode Reverse Recovery Charge	Q _{rr}	dI _F /dt=100A/μs		355		nC

Notes: 1. Pulse Test: Pulse width ≤ 300μs, Duty cycle ≤ 2%.

2. Essentially independent of operating ambient temperature.

■ TEST CIRCUITS AND WAVEFORMS

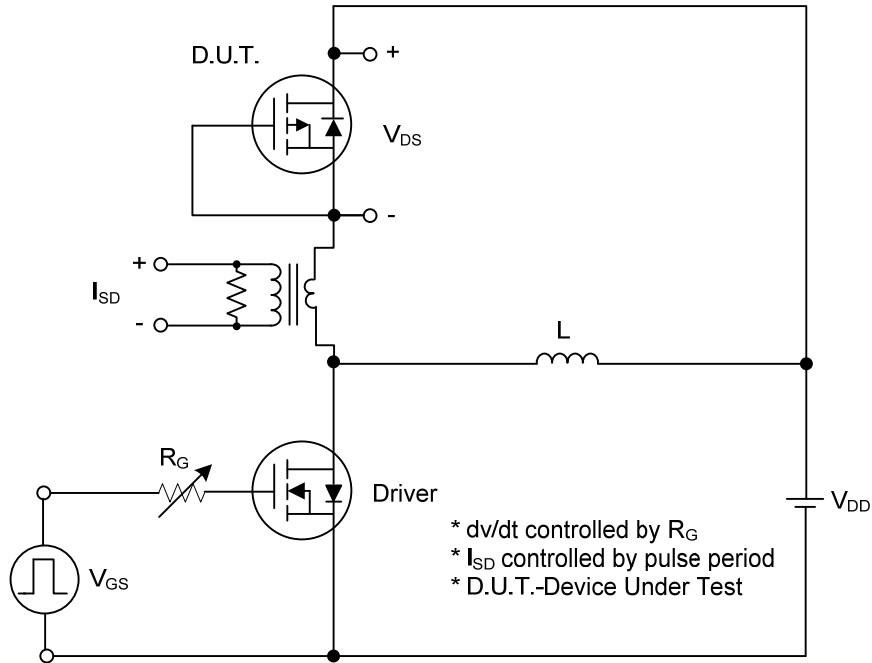

Peak Diode Recovery dv/dt Test Circuit

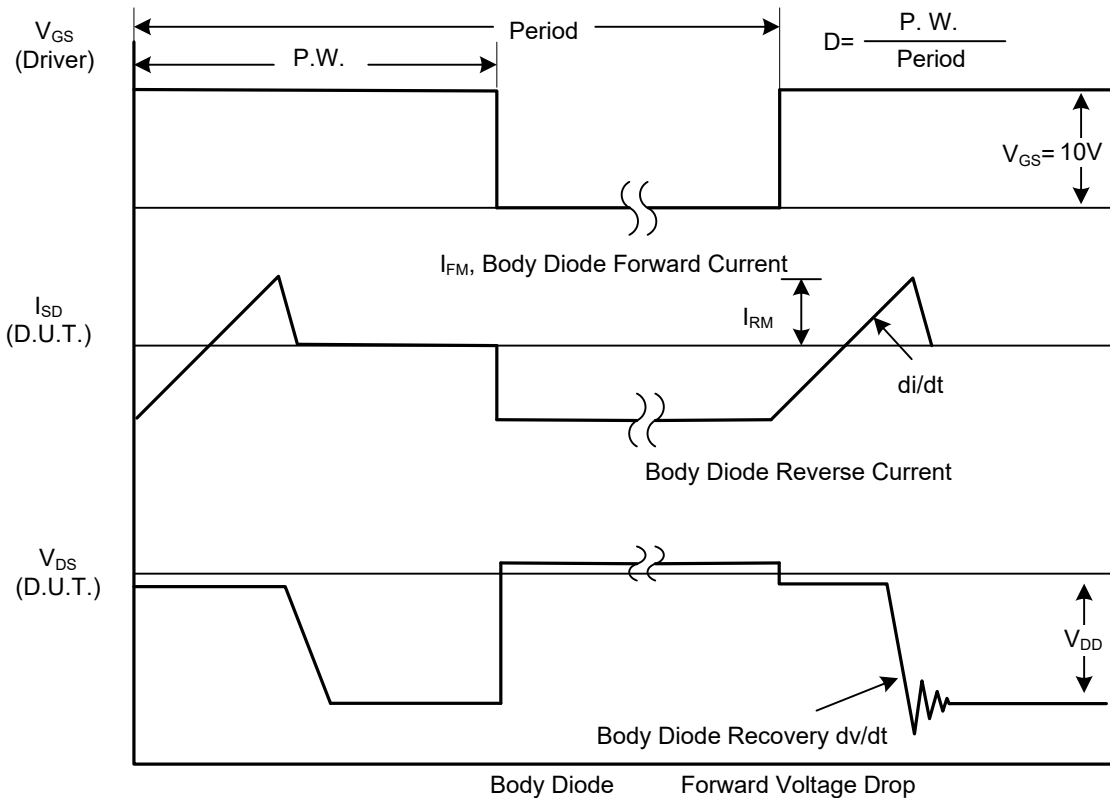

Peak Diode Recovery dv/dt Waveforms

TEST CIRCUITS AND WAVEFORMS

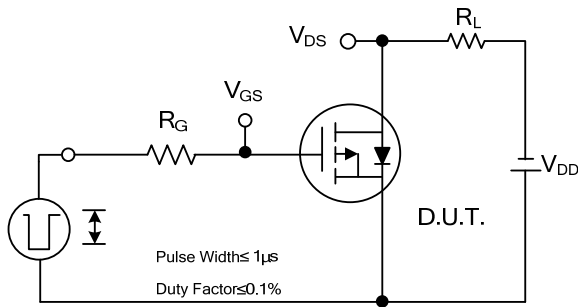

Switching Test Circuit

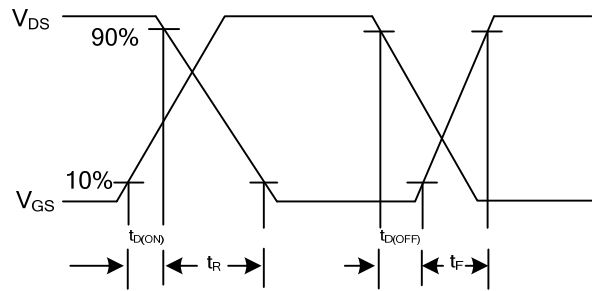

Switching Waveforms

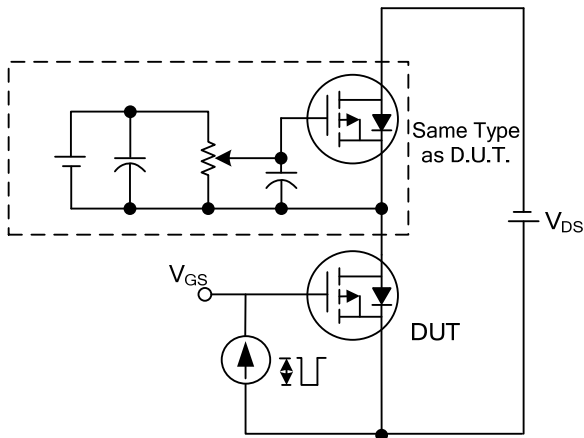

Gate Charge Test Circuit

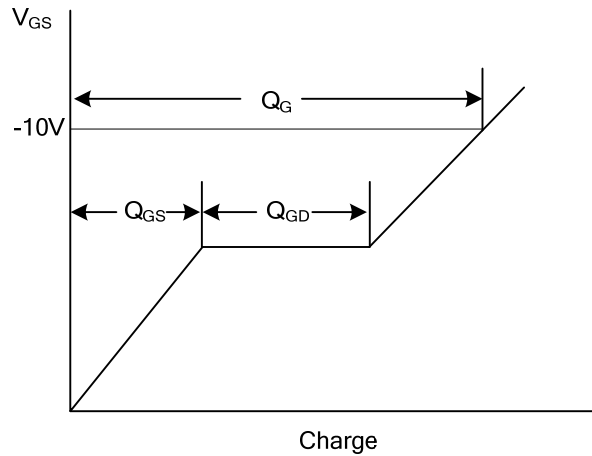

Gate Charge Waveform

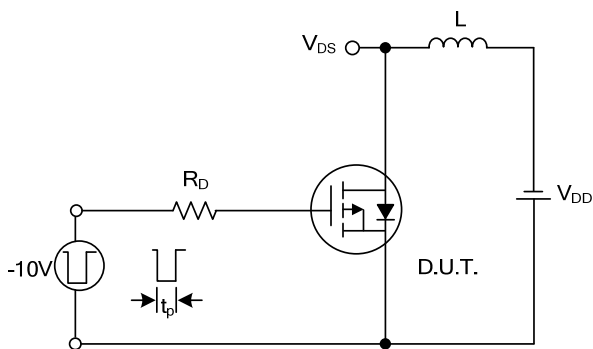

Unclamped Inductive Switching Test Circuit

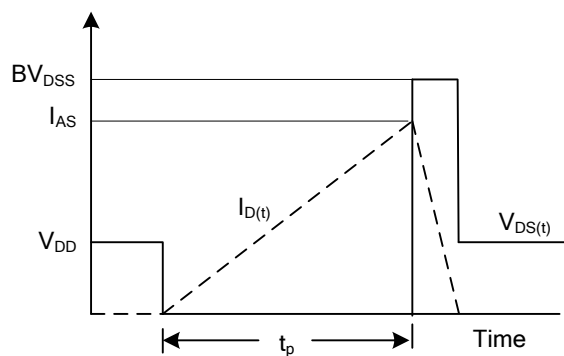

Unclamped Inductive Switching Waveforms

TYPICAL CHARACTERISTICS

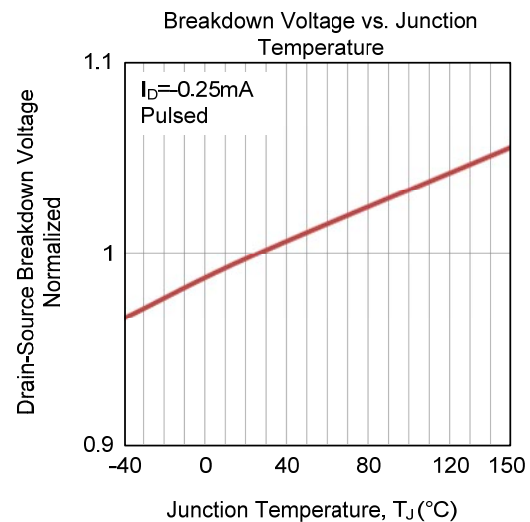
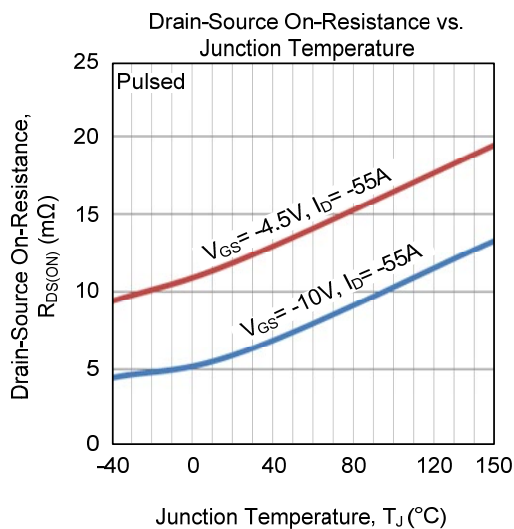
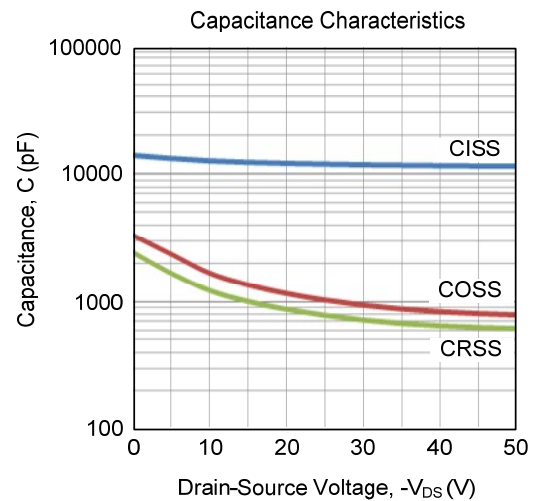
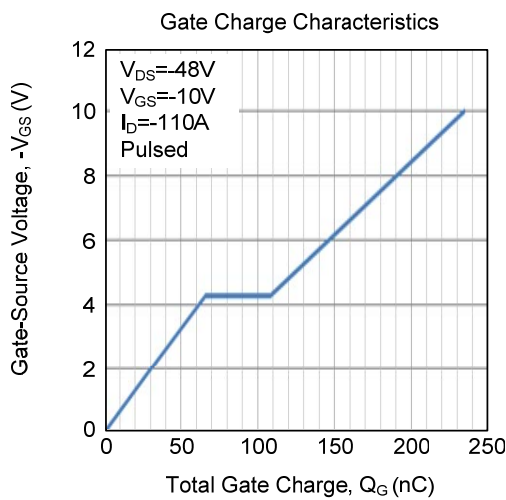
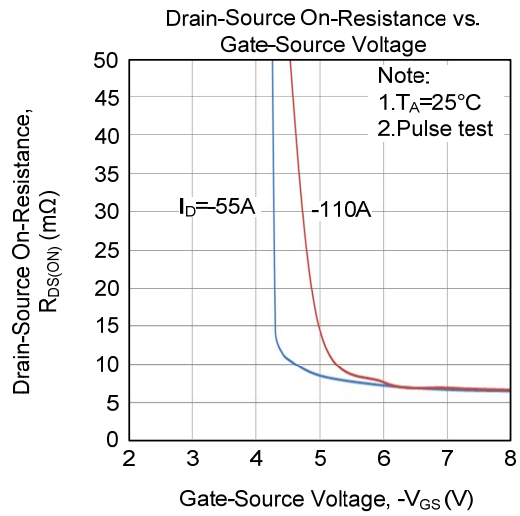
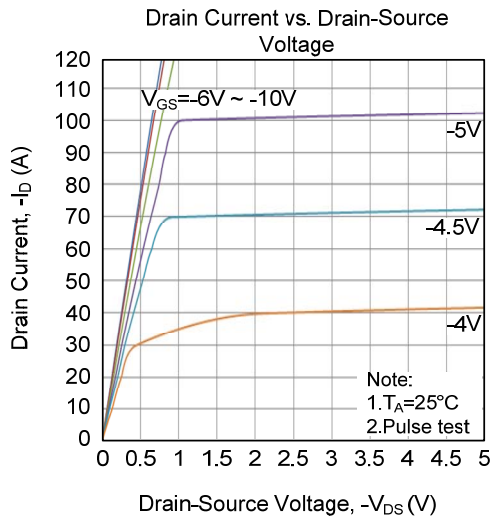

TYPICAL CHARACTERISTICS (Cont.)

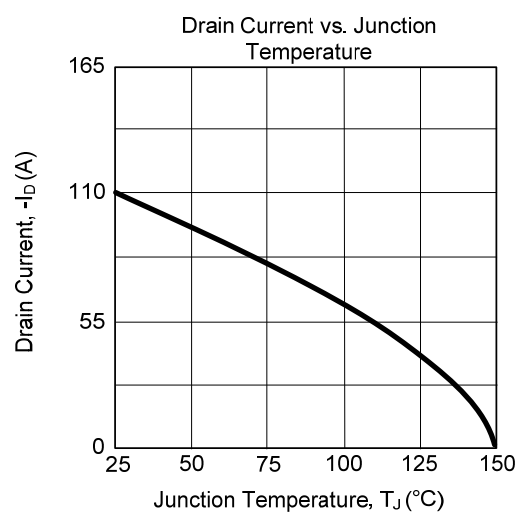
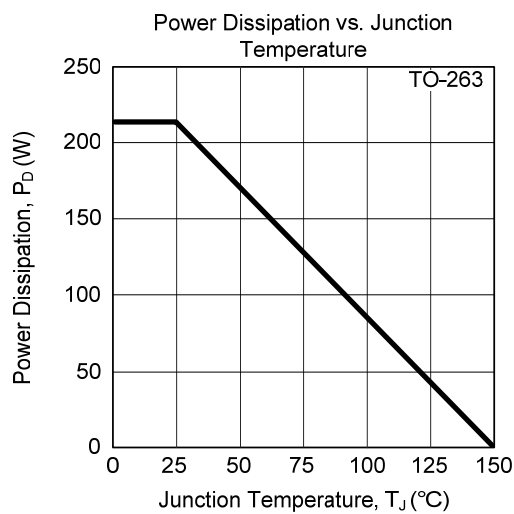
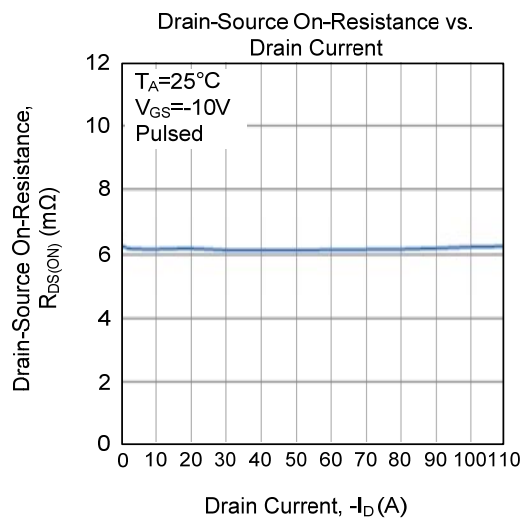
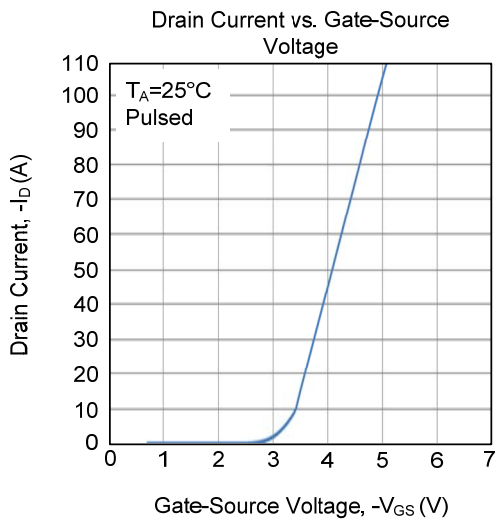
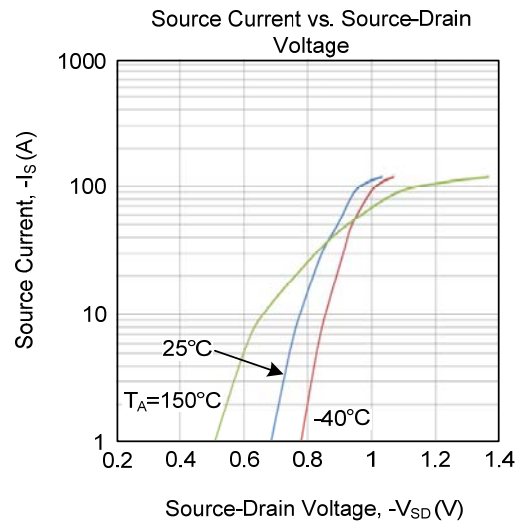
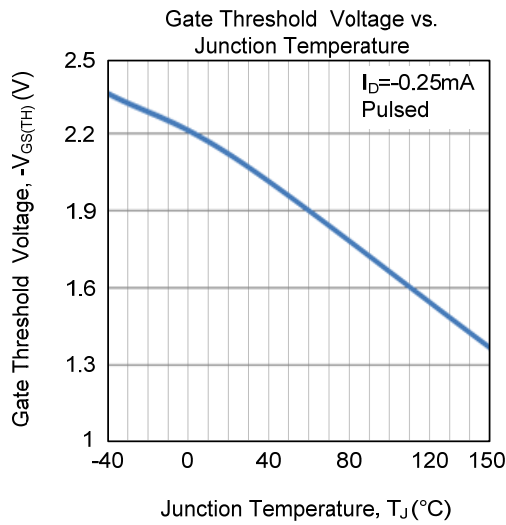

■ TYPICAL CHARACTERISTICS (Cont.)

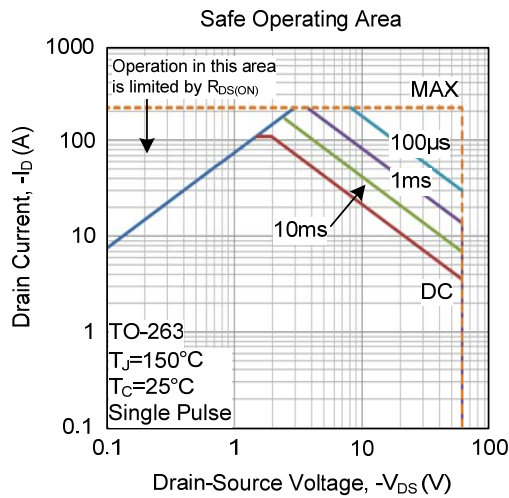

UTC assumes no responsibility for equipment failures that result from using products at values that exceed, even momentarily, rated values (such as maximum ratings, operating condition ranges, or other parameters) listed in products specifications of any and all UTC products described or contained herein. UTC products are not designed for use in life support appliances, devices or systems where malfunction of these products can be reasonably expected to result in personal injury. Reproduction in whole or in part is prohibited without the prior written consent of the copyright owner. UTC reserves the right to make changes to information published in this document, including without limitation specifications and product descriptions, at any time and without notice. This document supersedes and replaces all information supplied prior to the publication hereof.