



UTG75N120LND2

Insulated Gate Bipolar Transistor

1200V TRENCH GATE FIELD-STOP IGBT

DESCRIPTION

The UTC **UTG75N120LND2** is an Trench Field-Stop Insulated Gate Bipolar Transistor. it uses UTC's advanced technology to provide customers with high switching speed, low saturation voltage and low switching loss, etc.

The UTC **UTG75N120LND2** is suitable for the resonant or soft switching applications.

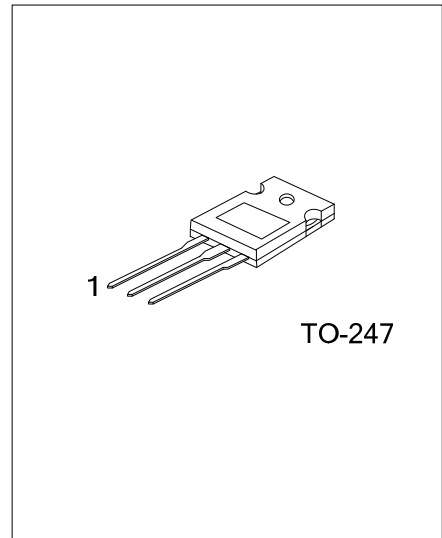

FEATURES

- * High switching speed
- * High avalanche ruggedness
- * Low saturation voltage: $V_{CE(SAT),Typ.}=2.0V @ I_C=75A, V_{GE}=15V$ ($T_C = 25^\circ C$)

SYMBOL

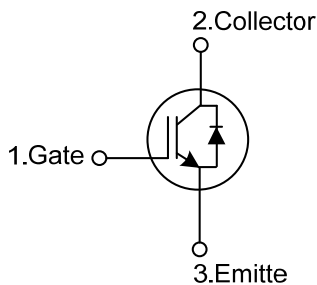

ORDERING INFORMATION

Ordering Number		Package	Pin Assignment			Packing
Lead Free	Halogen Free		1	2	3	
UTG75N120LND2L-T47-T	UTG75N120LND2G-T47-T	TO-247	G	C	E	Tube

Note: Pin Assignment: G: Gate C: Collector E: Emitter

UTG75N120LND2G-T47-T 	(1) Packing Type (2) Package Type (3) Green Package	(1) T: Tube (2) T47: TO-247 (3) G: Halogen Free and Lead Free, L: Lead Free
--------------------------	---	---

UTG75N120LND2

Insulated Gate Bipolar Transistor

■ MARKING

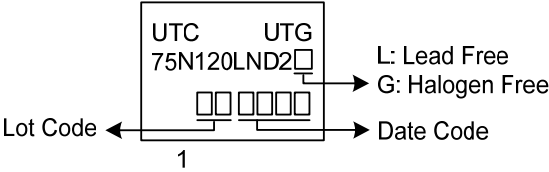

■ ABSOLUTE MAXIMUM RATINGS (T_A=25°C, unless otherwise noted)

PARAMETER	SYMBOL	RATINGS	UNIT	
Collector-Emitter Voltage	V _{CEs}	1200	V	
Gate-Emitter Voltage	V _{GES}	±20	V	
Transient Gate-emitter voltage (tp < 5 ms)		±25	V	
Continuous Collector Current	I _C	T _C =25°C	150	A
		T _C =100°C	75	A
Collector Current Pulsed (Note 1)	I _{CM}	300	A	
Diode Forward Current	I _F	T _C =25°C	150	A
		T _C =100°C	75	A
Short Circuit Withstand Time V _{GE} = 15V, V _{CC} ≤ 200V Allowed number of short circuits < 1000 Time between short circuits: ≥ 1.0s T _{VJ} = 25°C	t _{SC}	8	μs	
Power Dissipation (T _C =25°C)	P _D	320	W	
Operating Junction Temperature	T _J	-40 ~ +150	°C	
Storage Temperature Range	T _{STG}	-55 ~ +150	°C	

Notes: 1. Absolute maximum ratings are stress ratings only and functional device operation is not implied.
Absolute maximum ratings are those values beyond which the device could be permanently damaged.
2. Pulse width limited by maximum junction temperature.

■ THERMAL DATA

PARAMETER	SYMBOL	RATING	UNIT
Junction to Case	θ _{JC}	0.39	°C/W

■ ELECTRICAL CHARACTERISTICS (T_c=25°C, unless otherwise noted)

PARAMETER	SYMBOL	TEST CONDITIONS	MIN	TYP	MAX	UNIT	
Off Characteristics							
Collector-Emitter Breakdown Voltage	BV _{CES}		1200			V	
Collector Cut-Off Current	I _{CES}	V _{CE} =1200V, V _{GE} =0V			5	μA	
G-E Leakage Current	I _{GES}	V _{CE} =0V, V _{GE} =±20V			±400	nA	
On Characteristics							
Gate to Emitter Threshold Voltage	V _{GE(TH)}	I _C =250μA, V _{CE} =V _{GE}	4.5		7.5	V	
Collector to Emitter Saturation Voltage	V _{CE(SAT)}	I _C =75A, V _{GE} =15V	T _C =25°C	2.0	2.5	V	
			T _C =125°C	2.4		V	
Dynamic Characteristics							
Input Capacitance	C _{IES}	V _{CE} =25V, V _{GE} =0V, f=1MHz		2.3		nF	
Output Capacitance	C _{OES}			197		pF	
Reverse Transfer Capacitance	C _{RES}			114		pF	
Switching Characteristics							
Total Gate Charge	Q _G	V _{CE} =600V, I _C =75A, V _{GE} =15V		198		nC	
Gate-Emitter Charge	Q _{GE}			22		nC	
Gate-Collector Charge	Q _{GC}			136		nC	
Turn-On Delay Time	t _{DON)}	V _{CC} =600V, I _C =75A, R _G =5Ω, V _{GE} =0~15V, L=500μH		23		ns	
Rise Time	t _R			100		ns	
Turn-Off Delay Time	t _{DOFF)}			227		ns	
Fall Time	t _F			168		ns	
Turn-On Switching Loss	E _{ON}			9		mJ	
Turn-Off Switching Loss	E _{OFF}			6		mJ	
SOURCE- DRAIN DIODE RATINGS AND CHARACTERISTICS							
Forward Voltage Drop	V _F		I _F =75A			2.2	V
Reverse Recovery Time	t _{rr}	I _F =75A, dI/dt=100A/μS,		544		ns	
Reverse Recovery Charge	Q _{rr}	V _{CC} =600V		5.5		μC	

TYPICAL CHARACTERISTICS

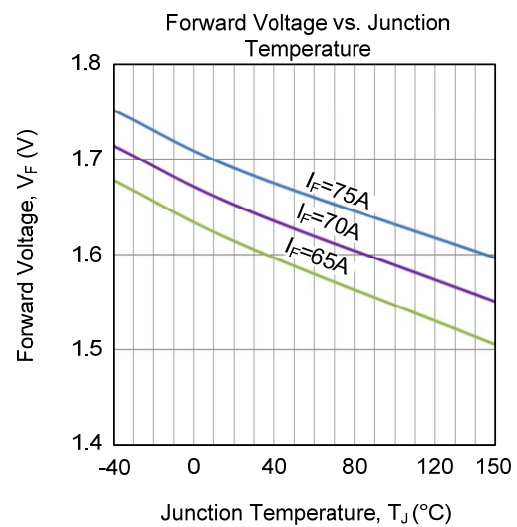
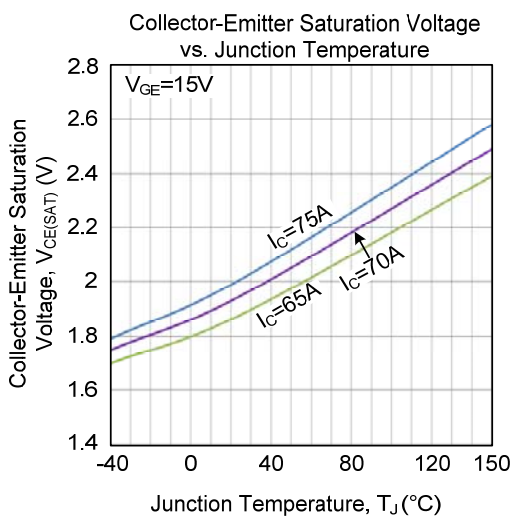
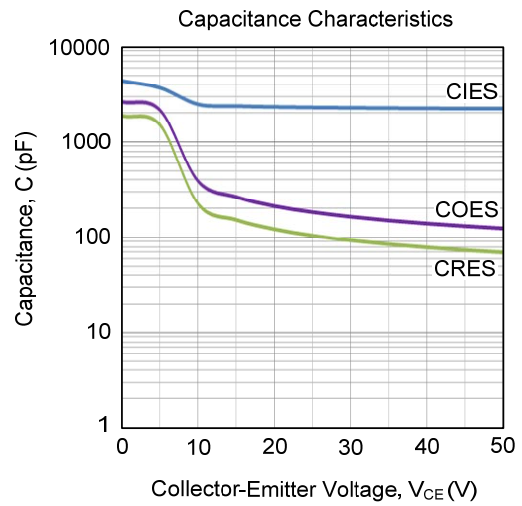
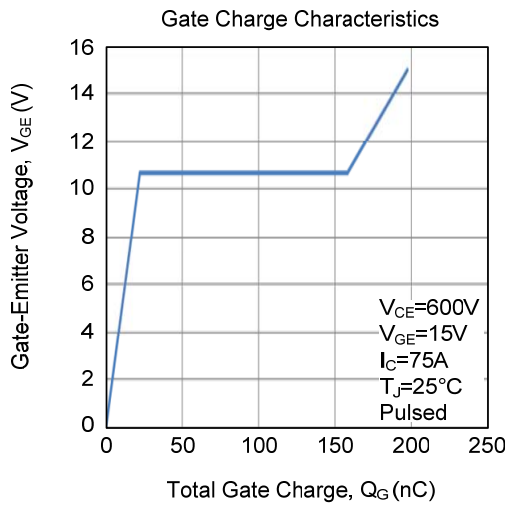
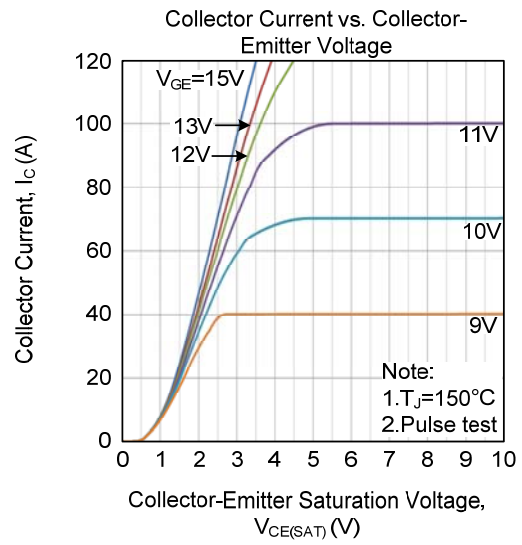
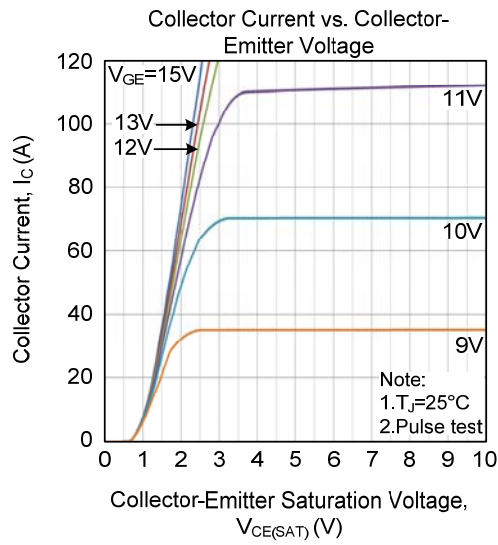

TYPICAL CHARACTERISTICS (Cont.)

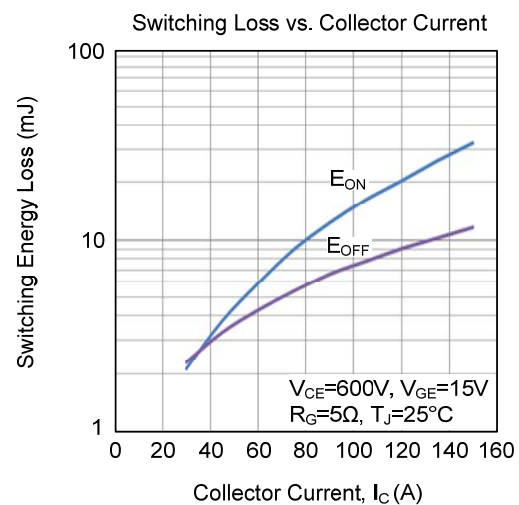
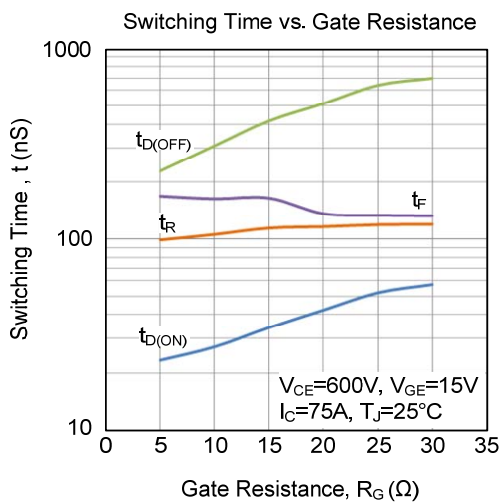
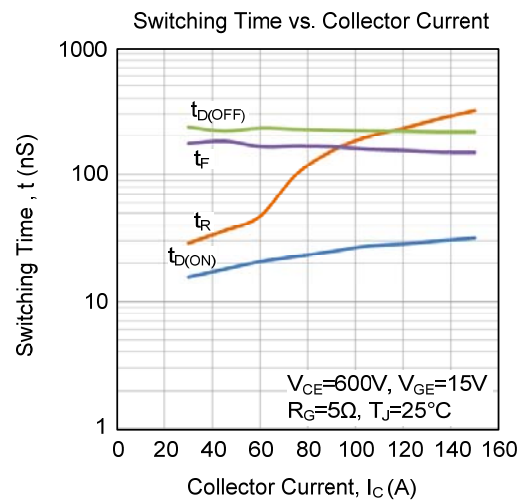
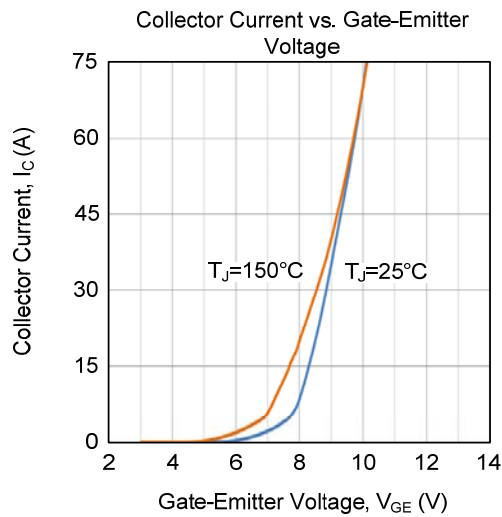
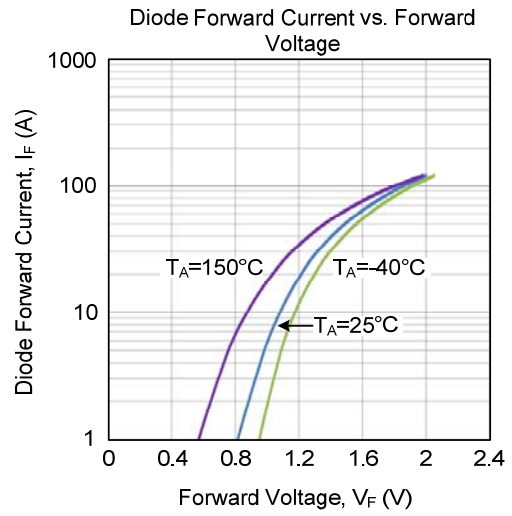
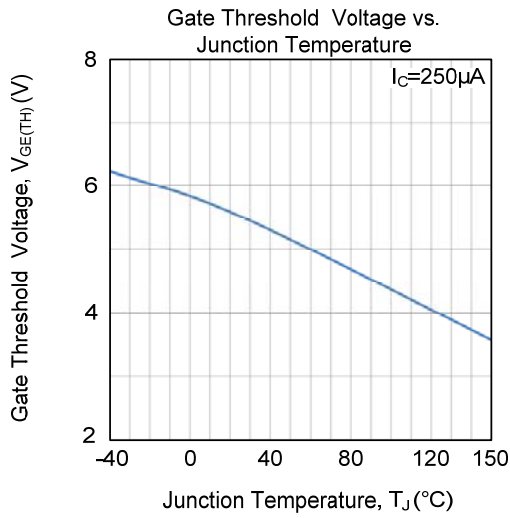

■ TYPICAL CHARACTERISTICS (Cont.)

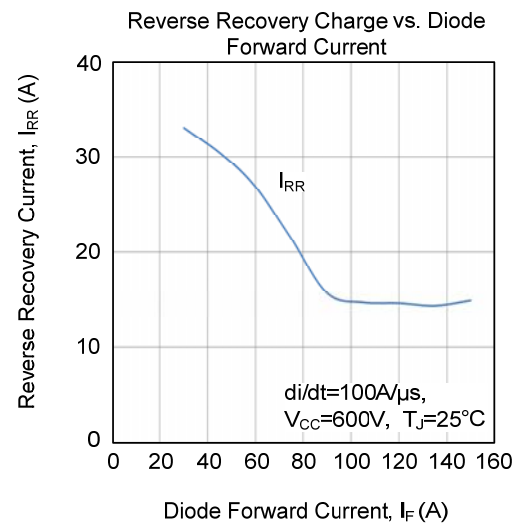
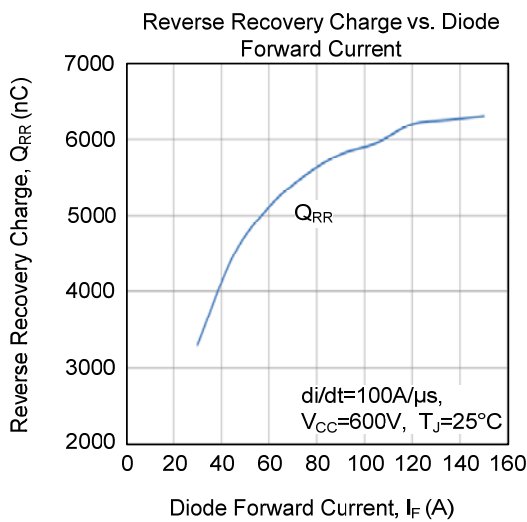
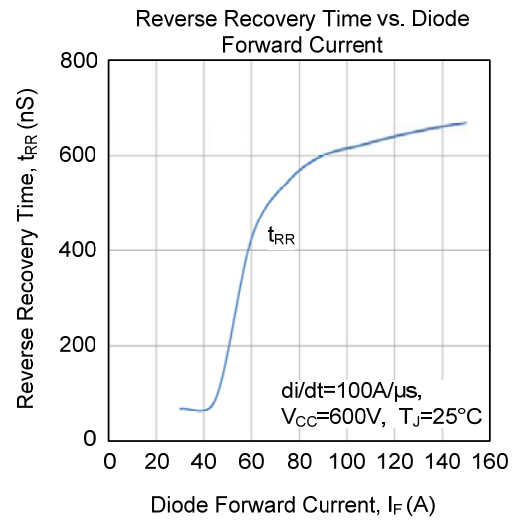
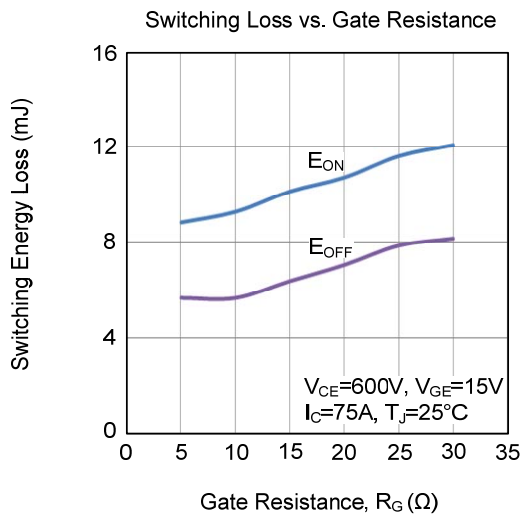

UTC assumes no responsibility for equipment failures that result from using products at values that exceed, even momentarily, rated values (such as maximum ratings, operating condition ranges, or other parameters) listed in products specifications of any and all UTC products described or contained herein. UTC products are not designed for use in life support appliances, devices or systems where malfunction of these products can be reasonably expected to result in personal injury. Reproduction in whole or in part is prohibited without the prior written consent of the copyright owner. UTC reserves the right to make changes to information published in this document, including without limitation specifications and product descriptions, at any time and without notice. This document supersedes and replaces all information supplied prior to the publication hereof.