



U74LVC1G125B

CMOS IC

BUS BUFFER/LINE DRIVER 3-STATE

DESCRIPTION

The **U74LVC1G125B** is a single bus buffer/line driver with 3-state output. When the output enable (\overline{OE}) is high the output will be disabled. In contrast, when the \overline{OE} is low, true data will pass from A input to the Y output.

This device has power-down protective circuit to prevent the device from destruction when it is powered down.

FEATURES

- * Operate From 1.65V to 5.5V
- * Inputs Accept Voltages to 5.5V
- * High Noise Immunity
- * Low Power Dissipation
- * Direct Interface With TTL Level

ORDERING INFORMATION

Ordering Number		Package	Packing
Lead Free	Halogen Free		
U74LVC1G125BL-AE5-R	U74LVC1G125BG-AE5-R	SOT-23-5	Tape Reel
U74LVC1G125BL-AF5-R	U74LVC1G125BG-AF5-R	SOT-25	Tape Reel
U74LVC1G125BL-AL5-R	U74LVC1G125BG-AL5-R	SOT-353	Tape Reel
U74LVC1G125BL-AN5-R	U74LVC1G125BG-AN5-R	SOT-553	Tape Reel
U74LVC1G125BL-KAP-R	U74LVC1G125BG-KAP-R	X1DFN14510-6	Tape Reel
U74LVC1G125BL-KAR-R	U74LVC1G125BG-KAR-R	X2DFN0808-4	Tape Reel

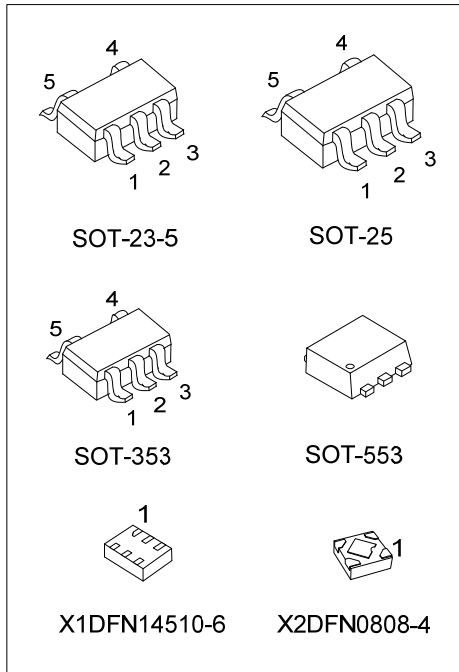

<p>U74LVC1G125BG-AE5-R</p>	<p>(1) R: Tape Reel (2) AE5: SOT-23-5, AF5: SOT-25, AL5: SOT-353 AN5: SOT-553, KAP: X1DFN14510-6 KAR: X2DFN0808-4 (3) G: Halogen Free and Lead Free, L: Lead Free</p>
----------------------------	---

MARKING

<p>SOT-23-5 / SOT-25 / SOT-353 / SOT-553</p> <p>L: Lead Free G: Halogen Free</p>	<p>X1DFN14510-6/X2DFN0808-4</p>
--	---------------------------------

■ PIN CONFIGURATION

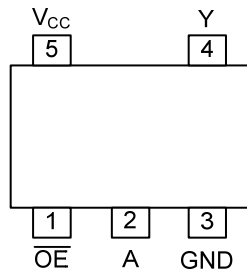

SOT-23-5 / SOT-25
SOT-353 / SOT-553

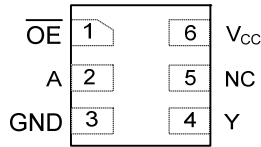

X1DFN14510-6
(TOP VIEW)

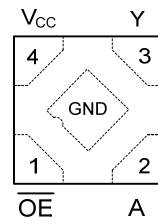

X2DFN0808-4
(TOP VIEW)

■ FUNCTION TABLE

INPUT(\overline{OE})	INPUT(A)	OUTPUT(Y)
L	L	L
L	H	H
H	X	Z

Note: H: HIGH voltage level; L: LOW voltage level; X=don't care; Z=high-impedance OFF-state.

■ LOGIC DIAGRAM (Positive Logic)

For SOT-23-5/SOT-25/SOT-353/SOT-553/X1DFN14510-6

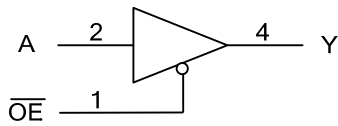

Logic Symbol

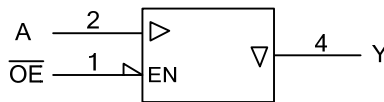

IEC Logic Symbol

For X2DFN0808-4

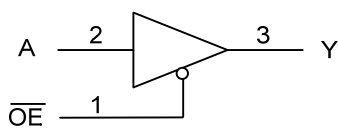

Logic Symbol

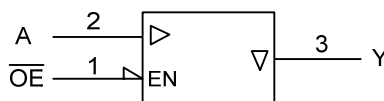

IEC Logic Symbol

■ ABSOLUTE MAXIMUM RATING (Note 1, 3)

PARAMETER		SYMBOL	CONDITIONS	RATINGS	UNIT
Supply Voltage		V_{CC}		-0.5 ~ +6.5	V
Input Voltage		V_{IN}		-0.5 ~ +6.5	V
Output Voltage	Enable mode	V_{OUT}		-0.5 ~ $V_{CC} + 0.5$	V
	Disable mode			-0.5 ~ +6.5	V
	Power-down mode			-0.5 ~ +6.5	V
V_{CC} or GND Current		I_{CC}		±100	mA
Continuous Output Current		I_{OUT}	$V_{OUT}=0$ to V_{CC}	±50	mA
Input Clamp Current (Note 2)		I_{IK}	$V_{IN}<0$	-50	mA
Output Clamp Current (Note 2)		I_{OK}	$V_{OUT}<0$	-50	mA
Power Dissipation	SOT-23-5	P_D	$T_A=-40^{\circ}C\sim+125^{\circ}C$	300	mW
	SOT-25			360	mW
	SOT-353			250	mW
	SOT-553			250	mW
	X1DFN14510-6			200	mW
	X2DFN0808-4			250	mW
Operating Temperature		T_{OPR}		-40 ~ +125	°C
Storage Temperature		T_{STG}		-65 ~ +150	°C

Notes: 1. Absolute maximum ratings are those values beyond which the device could be permanently damaged.

Absolute maximum ratings are stress ratings only and functional device operation is not implied.

2. The input and output voltage ratings may be exceeded if the input and output current ratings are observed.

3. It is guarantee by design, not 100% be tested.

■ THERMAL DATA

PARAMETER		SYMBOL	RATINGS	UNIT
Junction to Ambient	SOT-23-5	θ_{JA}	280	°C/W
	SOT-25		230	°C/W
	SOT-353		350	°C/W
	SOT-553		370	°C/W
	X1DFN14510-6		440	°C/W
	X2DFN0808-4		350	°C/W

■ RECOMMENDED OPERATING CONDITIONS

PARAMETER	SYMBOL	CONDITIONS	MIN	TYP	MAX	UNIT
Supply Voltage	V_{CC}	Operating	1.65		5.5	V
Input Voltage	V_{IN}		0		5.5	V
Output Voltage	V_{OUT}	$V_{CC}=1.65V \sim 5.5V$; Enable mode	0		V_{CC}	V
		$V_{CC}=1.65V \sim 5.5V$; Disable mode	0		5.5	V
		$V_{CC}=0V$; Power-down mode	0		5.5	V
Input Transition Rise or Fall Rate	$\Delta t/\Delta V$	$V_{CC}=1.65V \sim 2.7V$			20	ns/V
		$V_{CC}=2.7V \sim 5.5V$			10	ns/V

■ ELECTRICAL CHARACTERISTICS (Unless otherwise specified)

PARAMETER	SYMBOL	TEST CONDITIONS	T _A =25°C			T _A =-40°C~+125°C			UNIT
			MIN	TYP	MAX	MIN	TYP	MAX	
High-Level Input Voltage	V _{IH}	V _{CC} =1.65V ~ 1.95V	0.65× V _{CC}			0.65× V _{CC}			V
		V _{CC} =2.3V ~ 2.7V	1.7			1.7			V
		V _{CC} =2.7V ~ 3.6V	2			2			V
		V _{CC} =4.5V ~ 5.5V	0.7× V _{CC}			0.7× V _{CC}			V
Low-Level Input Voltage	V _{IL}	V _{CC} =1.65V ~ 1.95V			0.35× V _{CC}			0.35× V _{CC}	V
		V _{CC} =2.3V ~ 2.7V			0.7			0.7	V
		V _{CC} =2.7V ~ 3.6V			0.8			0.8	V
		V _{CC} =4.5V ~ 5.5V			0.3× V _{CC}			0.3× V _{CC}	V
High-Level Output Voltage	V _{OH}	V _{CC} =1.65V ~ 5.5V, I _{OH} =-100μA	V _{CC} -0.1			V _{CC} -0.1			V
		V _{CC} =1.65V, I _{OH} =-4mA	1.2			0.95			V
		V _{CC} =2.3V, I _{OH} =-8mA	1.9			1.7			V
		V _{CC} =2.7V, I _{OH} =-12mA	2.2			1.9			V
		V _{CC} =3.0V, I _{OH} =-24mA	2.3			2			V
		V _{CC} =4.5V, I _{OH} =-32mA	3.8			3.4			V
Low-Level Output Voltage	V _{OL}	V _{CC} =1.65V ~ 5.5V, I _{OL} =100μA			0.1			0.1	V
		V _{CC} =1.65V, I _{OL} =4mA			0.45			0.7	V
		V _{CC} =2.3V, I _{OL} =8mA			0.3			0.45	V
		V _{CC} =2.7V, I _{OL} =12mA			0.4			0.6	V
		V _{CC} =3.0V, I _{OL} =24mA			0.55			0.8	V
		V _{CC} =4.5V, I _{OL} =32mA			0.55			0.8	V
Input Leakage Current	I _{I(LEAK)}	V _{CC} =5.5V, V _{IN} =5.5V or GND			±5			±5	μA
Power OFF Leakage Current	I _{OFF}	V _{CC} =0V, V _{IN} or V _{OUT} =5.5V			±10			±10	μA
3-State Output OFF-State Current	I _{OZ}	V _{CC} =5.5V, V _{IN} =V _{IH} or V _{IL} , V _{OUT} =V _{CC} or GND			±10			±10	μA
Quiescent Supply Current	I _Q	V _{CC} =5.5V, V _{IN} =V _{CC} or GND, I _{OUT} =0			10			10	μA
Additional Quiescent Supply Current Per Input Pin	ΔI _Q	V _{CC} =2.3V ~ 5.5V, V _{IN} =V _{CC} -0.6V, I _{OUT} =0			500			500	μA

■ SWITCHING CHARACTERISTICS (Unless otherwise specified)

PARAMETER	SYMBOL	TEST CONDITIONS	T _A =25°C			T _A =-40°C~+125°C			UNIT	
			MIN	TYP	MAX	MIN	TYP	MAX		
Propagation Delay From Input A to Output Y	t _{PLH} / t _{PHL}	C _L =30pF	V _{CC} =1.8V±0.15V, R _L =1KΩ	1	10	19			21	ns
			V _{CC} =2.5V±0.2V, R _L =500Ω	0.5	8	15			17	ns
		C _L =50pF, R _L =500Ω	V _{CC} =2.7V	0.5	7	12			14	ns
			V _{CC} =3.3V±0.3V	0.5	6	9			11	ns
			V _{CC} =5V±0.5V	0.5	5	8			10	ns
3-State Output Enable Time From Input OE to Output Y	t _{PZH} / t _{PZL}	C _L =30pF	V _{CC} =1.8V±0.15V, R _L =1KΩ	1	10	19			21	ns
			V _{CC} =2.5V±0.2V, R _L =500Ω	0.5	7	15			17	ns
		C _L =50pF, R _L =500Ω	V _{CC} =2.7V	0.5	5	12			14	ns
			V _{CC} =3.3V±0.3V	0.5	4	9			11	ns
			V _{CC} =5V±0.5V	0.5	3	7			9	ns
3-State Output Disable Time From Input OE to Output Y	t _{PLZ} / t _{PHZ}	C _L =30pF	V _{CC} =1.8V±0.15V, R _L =1KΩ	1	7	10			12	ns
			V _{CC} =2.5V±0.2V, R _L =500Ω	0.5	5	8			10	ns
		C _L =50pF, R _L =500Ω	V _{CC} =2.7V	0.5	4	7			9	ns
			V _{CC} =3.3V±0.3V	0.5	3	6			8	ns
			V _{CC} =5 V±0.5V	0.5	3	5			7	ns

TEST CIRCUIT AND WAVEFORMS

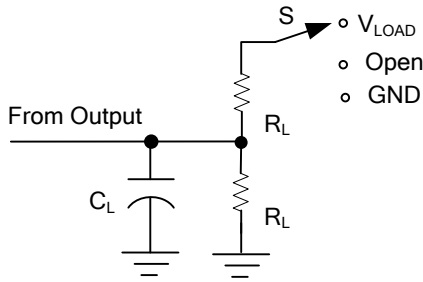

TEST	S
t_{PLH}/t_{PHL}	Open
t_{PHZ}/t_{PZH}	GND
t_{PLZ}/t_{PZL}	V_{LOAD}

TEST CIRCUIT

V_{CC}	INPUTS		V_M	V_{LOAD}	V_{Δ}	C_L	R_L
	V_{IN}	t_R, t_F					
$1.8V \pm 0.15V$	V_{CC}	$\leq 2ns$	$V_{CC}/2$	$2 \times V_{CC}$	0.15V	30pF	1K Ω
$2.5V \pm 0.2V$	V_{CC}	$\leq 2ns$	$V_{CC}/2$	$2 \times V_{CC}$	0.15V	30pF	500 Ω
2.7V	2.7V	$\leq 2.5ns$	1.5V	6V	0.3V	50pF	500 Ω
$3.3V \pm 0.3V$	2.7V	$\leq 2.5ns$	1.5V	6V	0.3V	50pF	500 Ω
$5V \pm 0.5V$	V_{CC}	$\leq 2.5ns$	$V_{CC}/2$	$2 \times V_{CC}$	0.3V	50pF	500 Ω

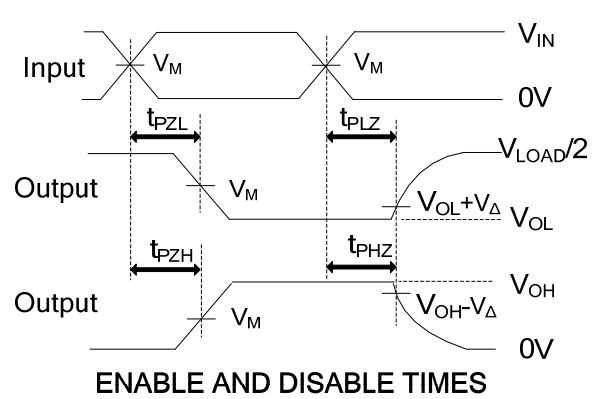
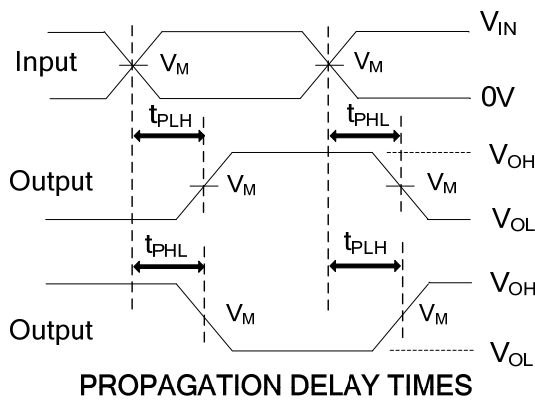

Notes: 1. C_L includes probe and jig capacitance.

2. All input pulses are supplied by generators having the following characteristics: $P_{RR} \leq 10MHz$, $Z_o = 50\Omega$.

UTC assumes no responsibility for equipment failures that result from using products at values that exceed, even momentarily, rated values (such as maximum ratings, operating condition ranges, or other parameters) listed in products specifications of any and all UTC products described or contained herein. UTC products are not designed for use in life support appliances, devices or systems where malfunction of these products can be reasonably expected to result in personal injury. Reproduction in whole or in part is prohibited without the prior written consent of the copyright owner. UTC reserves the right to make changes to information published in this document, including without limitation specifications and product descriptions, at any time and without notice. This document supersedes and replaces all information supplied prior to the publication hereof.