



USG12R200H

Preliminary

Power MOSFET

**N-CHANNEL SGT
ENHANCEMENT POWER
MOSFET**

■ DESCRIPTION

The UTC **USG12R200H** is a N-channel Power MOSFET, it uses UTC's advanced technology to provide the customers with high switching speed and low gate charge, etc.

The UTC **USG12R200H** applies to primary side switch, synchronous rectifier, Motor Drives, etc.

■ FEATURES

- * $R_{DS(ON)} \leq 20 \text{ m}\Omega$ @ $V_{GS} = 10\text{V}$, $I_D = 20\text{A}$
- * Extremely low switching loss
- * Excellent stability and uniformity

■ SYMBOL

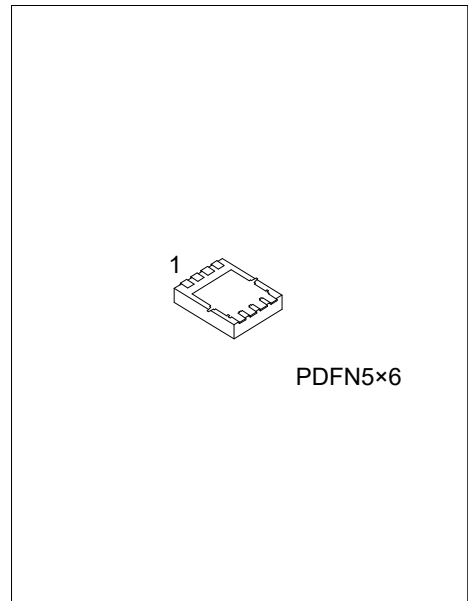
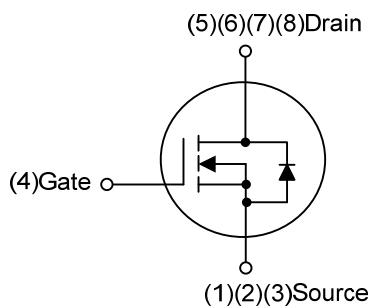

■ ORDERING INFORMATION

Ordering Number		Package	Pin Assignment								Packing
Lead Free	Halogen Free		1	2	3	4	5	6	7	8	
USG12R200HL-P5060-R	USG12R200HG-P5060-R	PDFN5x6	S	S	S	G	D	D	D	D	Tape Reel

Note: Pin Assignment: S: Source G: Gate D: Drain

<p>USG12R200HG-P5060-R</p>	<p>(1) R: Tape Reel</p> <p>(2) P5060: PDFN5x6</p> <p>(3) G: Halogen Free and Lead Free, L: Lead Free</p>
----------------------------	--

MARKING

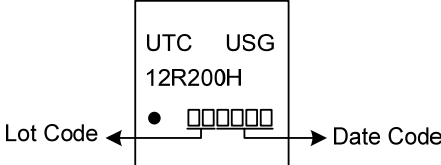

■ ABSOLUTE MAXIMUM RATINGS ($T_C=25^\circ\text{C}$, unless otherwise specified)

PARAMETER		SYMBOL	RATINGS	UNIT
Drain-Source Voltage		V_{DSS}	120	V
Gate-Source Voltage		V_{GSS}	± 20	V
Drain Current	Continuous	I_D	40	A
	Pulsed (Note 2)	I_{DM}	80	A
Single Pulsed Avalanche Energy (Note 3)		E_{AS}	15.4	mJ
Peak Diode Recovery dv/dt (Note 4)		dv/dt	18.5	V/ns
Power Dissipation		P_D	32	W
Junction Temperature		T_J	+150	$^\circ\text{C}$
Storage Temperature		T_{STG}	-55 ~ +150	$^\circ\text{C}$

Notes: 1. Absolute maximum ratings are those values beyond which the device could be permanently damaged.

Absolute maximum ratings are stress ratings only and functional device operation is not implied.

2. Repetitive Rating: Pulse width limited by maximum junction temperature.

3. $L = 0.1\text{mH}$, $I_{AS} = 17.55\text{A}$, $V_{DD} = 50\text{V}$, $R_G = 25\Omega$, Starting $T_J = 25^\circ\text{C}$

4. $I_{SD} \leq 1\text{A}$, $di/dt \leq 200\text{A}/\mu\text{s}$, $V_{DD} \leq BV_{DSS}$, $T_J \leq T_{JMAX}$, $T_J = 25^\circ\text{C}$.

■ THERMAL DATA

PARAMETER	SYMBOL	RATINGS	UNIT
Junction to Ambient	θ_{JA}	65	$^\circ\text{C}/\text{W}$
Junction to Case	θ_{JC}	3.9 (Note)	$^\circ\text{C}/\text{W}$

Note: Device mounted on FR-4 substrate PC board, 2oz copper, with 1inch square copper plate.

■ ELECTRICAL CHARACTERISTICS ($T_J=25^\circ\text{C}$, unless otherwise specified)

PARAMETER	SYMBOL	TEST CONDITIONS	MIN	TYP	MAX	UNIT
OFF CHARACTERISTICS						
Drain-Source Breakdown Voltage	BV_{DSS}	$I_D=250\mu\text{A}$, $V_{GS}=0\text{V}$	120			V
Drain-Source Leakage Current	I_{DSS}	$V_{DS}=120\text{V}$, $V_{GS}=0\text{V}$			1	μA
Gate-Source Leakage Current	I_{GSS}	Forward			+100	nA
		Reverse			-100	nA
ON CHARACTERISTICS						
Gate Threshold Voltage	$V_{GS(TH)}$	$V_{DS}=V_{GS}$, $I_D=250\mu\text{A}$	2.0		4.0	V
Static Drain-Source On-State Resistance	$R_{DS(ON)}$	$V_{GS}=10\text{V}$, $I_D=20\text{A}$			20	m Ω
DYNAMIC PARAMETERS						
Input Capacitance	C_{ISS}	$V_{DS}=25\text{V}$, $V_{GS}=0\text{V}$, $f=1.0\text{MHz}$		2161		pF
Output Capacitance	C_{OSS}			488		pF
Reverse Transfer Capacitance	C_{RSS}			39		pF
SWITCHING PARAMETERS						
Total Gate Charge	Q_G	$V_{DS}=96\text{V}$, $V_{GS}=10\text{V}$, $I_D=20\text{A}$		45		nC
Gate to Source Charge	Q_{GS}			20		nC
Gate to Drain Charge	Q_{GD}			14		nC
Turn-ON Delay Time	$t_{D(ON)}$	$V_{DD}=60\text{V}$, $V_{GS}=10\text{V}$, $I_D=20\text{A}$, $R_G=3\Omega$		21		ns
Rise Time	t_R			18		ns
Turn-OFF Delay Time	$t_{D(OFF)}$			32		ns
Fall-Time	t_F			17		ns
SOURCE- DRAIN DIODE RATINGS AND CHARACTERISTICS						
Maximum Body-Diode Continuous Current	I_S				40	A
Drain-Source Diode Forward Voltage	V_{SD}	$I_{SD}=40\text{A}$			1.4	V
Body Diode Reverse Recovery Time	t_{rr}	$I_S=10\text{A}$, $di/dt=100\text{A}/\mu\text{s}$		59		ns
Body Diode Reverse Recovery Charge	Q_{rr}			141		nC

Notes: 1. Pulse Test: Pulse width $\leq 300\mu\text{s}$, Duty cycle $\leq 2\%$.

2. Essentially independent of operating temperature.

TEST CIRCUITS AND WAVEFORMS

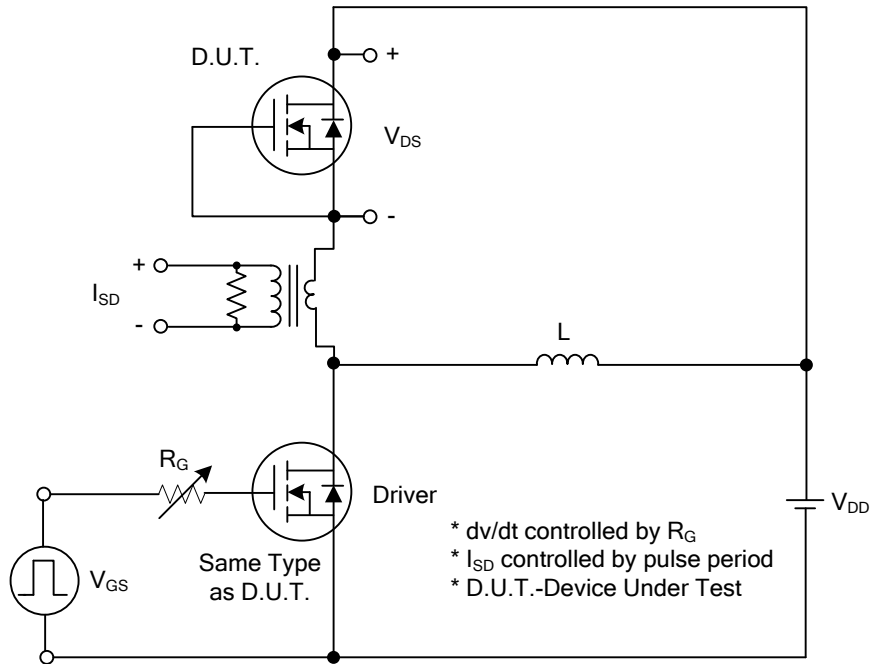

Peak Diode Recovery dv/dt Test Circuit

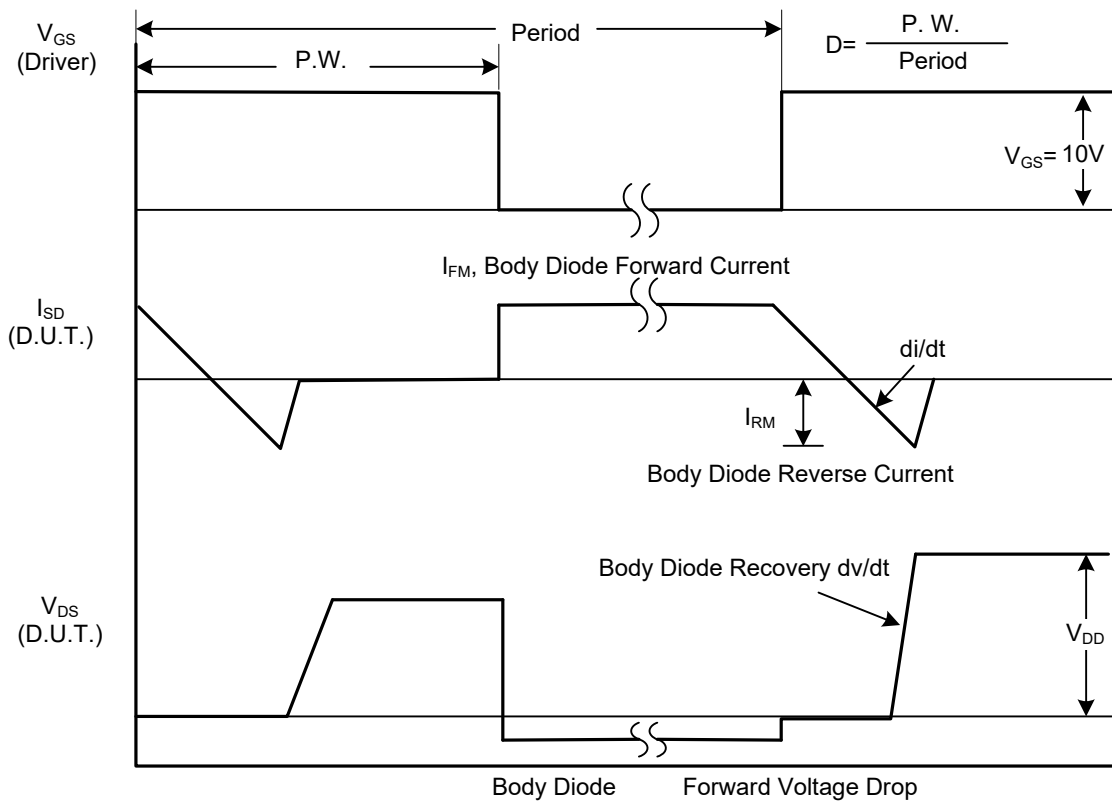

Peak Diode Recovery dv/dt Waveforms

UTC assumes no responsibility for equipment failures that result from using products at values that exceed, even momentarily, rated values (such as maximum ratings, operating condition ranges, or other parameters) listed in products specifications of any and all UTC products described or contained herein. UTC products are not designed for use in life support appliances, devices or systems where malfunction of these products can be reasonably expected to result in personal injury. Reproduction in whole or in part is prohibited without the prior written consent of the copyright owner. UTC reserves the right to make changes to information published in this document, including without limitation specifications and product descriptions, at any time and without notice. This document supersedes and replaces all information supplied prior to the publication hereof.