



USS4041NZ

Preliminary

NPN SILICON TRANSISTOR

7.0A, 60V NPN LOW $V_{CE(SAT)}$ TRANSISTOR

DESCRIPTION

The UTC **USS4041NZ** is NPN low $V_{CE(SAT)}$ transistor in a medium power and flat lead SOT-223 Surface-Mounted Device (SMD) plastic package.

PNP complement: USS4041PZ.

FEATURES

- * Very low collector-emitter saturation voltage $V_{CE(SAT)}$
- * High collector current capability I_C and I_{CM}
- * High collector current gain (h_{FE}) at high I_C
- * High energy efficiency due to less heat generation

EQUIVALENT CIRCUIT

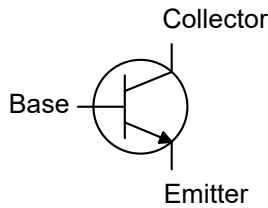

ORDERING INFORMATION

Ordering Number		Package	Pin Assignment			Packing
Lead Free	Halogen Free		1	2	3	
USS4041NZL-AA3-R	USS4041NZG-AA3-R	SOT-223	B	C	E	Tape Reel

Note: Pin Assignment: B: Base C: Collector E: Emitter

USS4041NZG-AA3-R	(1)Packing Type (2)Package Type (3)Green Package	(1) R: Tape Reel (2) AA3: SOT-223 (3) G: Halogen Free and Lead Free, L: Lead Free
------------------	--	---

MARKING

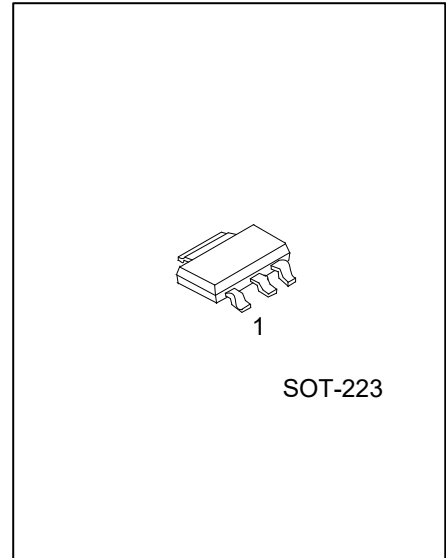
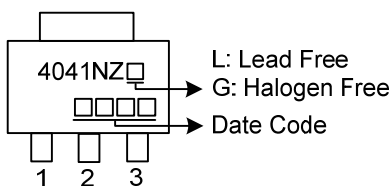

■ ABSOLUTE MAXIMUM RATING ($T_A=25^{\circ}\text{C}$, unless otherwise specified)

PARAMETER	SYMBOL	RATINGS	UNIT
Collector-Base Voltage	V_{CBO}	60	V
Collector-Emitter Voltage	V_{CEO}	60	V
Emitter-Base Voltage	V_{EBO}	5	V
Collector Current	I_C	7	A
Peak Collector Current	I_{CM}	15	A
Base Current	I_B	1	A
Power Dissipation	P_C	770	mW
Junction Temperature	T_J	+150	$^{\circ}\text{C}$
Operating Temperature	T_{OPR}	-40 ~ +150	$^{\circ}\text{C}$
Storage Temperature	T_{STG}	-55 ~ +150	$^{\circ}\text{C}$

Note: Absolute maximum ratings are those values beyond which the device could be permanently damaged. Absolute maximum ratings are stress ratings only and functional device operation is not implied.

■ THERMAL DATA

PARAMETER	SYMBOL	RATINGS	UNIT
Junction to Ambient	θ_{JA}	160	$^{\circ}\text{C}/\text{W}$

Note: Device mounted on FR-4 substrate PC board, 2oz copper, with 1inch square copper plate.

■ ELECTRICAL CHARACTERISTICS ($T_A=25^{\circ}\text{C}$, unless otherwise specified)

PARAMETER	SYMBOL	TEST CONDITIONS	MIN	TYP	MAX	UNIT
Collector-Base Breakdown Voltage	BV_{CBO}	$I_C=100\mu\text{A}, I_E=0$	60			V
Collector-Emitter Breakdown Voltage	BV_{CEO}	$I_C=10\text{mA}, I_B=0$	60			V
Emitter-Base Breakdown Voltage	BV_{EBO}	$I_E=100\mu\text{A}, I_C=0$	5			V
Collector-Base Cut-off Current	I_{CBO}	$V_{CB}=60\text{V}, I_E=0$			100	nA
Collector-Emitter Cut-off Current	I_{CES}	$V_{CE}=48\text{V}, V_{BE}=0\text{V}$			100	nA
Emitter-Base Cut-off Current	I_{EBO}	$V_{EB}=5\text{V}, I_C=0$			100	nA
Base-Emitter Saturation Voltage	$V_{BE(SAT)}$	$I_C=1\text{A}, I_B=100\text{mA}$			0.9	V
		$I_C=4\text{A}, I_B=400\text{mA}$			1.05	V
Base-Emitter Turn-On Voltage	$V_{BE(ON)}$	$V_{CE}=2\text{V}, I_C=2\text{A}$			0.85	V
DC Current Gain	h_{FE}	$V_{CE}=2\text{V}, I_C=500\text{mA}$	300			
		$V_{CE}=2\text{V}, I_C=1\text{A}$	300			
		$V_{CE}=2\text{V}, I_C=2\text{A}$	300			
		$V_{CE}=2\text{V}, I_C=4\text{A}$	250			
		$V_{CE}=2\text{V}, I_C=6\text{A}$	100			
		$V_{CE}=2\text{V}, I_C=7\text{A}$	50			
Collector-Emitter Saturation Voltage	$V_{CE(SAT)}$	$I_C=1\text{A}, I_B=10\text{mA}$			60	mV
		$I_C=1\text{A}, I_B=50\text{mA}$			35	mV
		$I_C=2\text{A}, I_B=40\text{mA}$			75	mV
		$I_C=4\text{A}, I_B=40\text{mA}$			160	mV
		$I_C=4\text{A}, I_B=200\text{mA}$			110	mV
		$I_C=7\text{A}, I_B=350\text{mA}$			195	mV

UTC assumes no responsibility for equipment failures that result from using products at values that exceed, even momentarily, rated values (such as maximum ratings, operating condition ranges, or other parameters) listed in products specifications of any and all UTC products described or contained herein. UTC products are not designed for use in life support appliances, devices or systems where malfunction of these products can be reasonably expected to result in personal injury. Reproduction in whole or in part is prohibited without the prior written consent of the copyright owner. UTC reserves the right to make changes to information published in this document, including without limitation specifications and product descriptions, at any time and without notice. This document supersedes and replaces all information supplied prior to the publication hereof.