



## UPG5N65QZ

Preliminary

Insulated Gate Bipolar Transistor

### 650V, SMPS N-CHANNEL IGBT

#### DESCRIPTION

The UTC **UPG5N65QZ** is a N-channel IGBT. it uses UTC's advanced technology to provide customers with high input impedance, high switching speed and low conduction loss, etc.

The UTC **UPG5N65QZ** is suitable for high voltage switching, high frequency switch mode power supplies.

#### FEATURES

- \* High switching speed
- \* High avalanche ruggedness
- \* Low saturation voltage:  $V_{CE(SAT),Typ.}=2.0V @ I_C=5.0A, V_{GE}=15V$  ( $T_C = 25^\circ C$ )
- \* With ESD Protected

#### SYMBOL

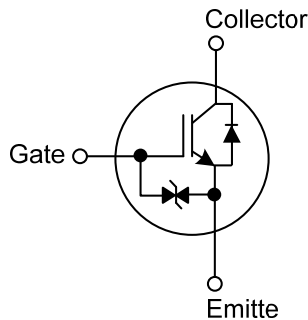

#### ORDERING INFORMATION

Ordering Number		Package	Pin Assignment			Packing
Lead Free	Halogen Free		1	2	3	
UPG5N65QZL-TN3-R	UPG5N65QZG-TN3-R	TO-252	G	C	E	Tape Reel

Note: Pin Assignment: G: Gate C: Collector E: Emitter

UPG5N65QZG-TN3-R	(1)Packing Type	(1) R: Tape Reel
	(2)Package Type	(2) TN3: TO-252
	(3)Green Package	(3) G: Halogen Free and Lead Free L: Lead Free

#### MARKING

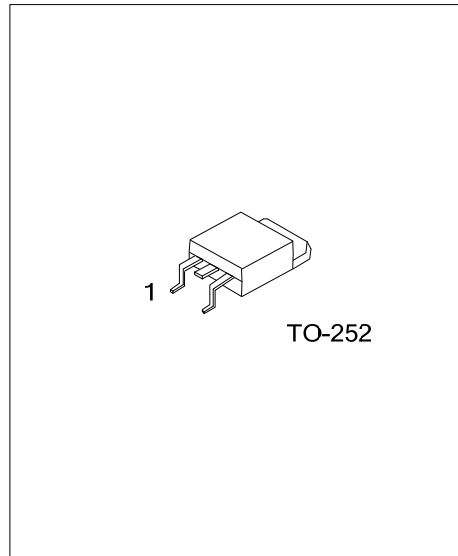
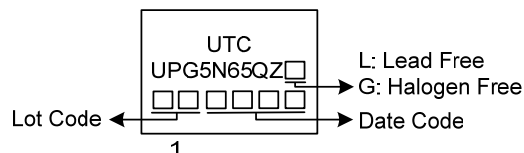

■ ABSOLUTE MAXIMUM RATINGS (T<sub>A</sub>=25°C, unless otherwise noted)

PARAMETER	SYMBOL	RATINGS	UNIT
Collector-Emitter Voltage	V <sub>CES</sub>	650	V
Gate-Emitter Voltage	V <sub>GES</sub>	±20	V
Transient Gate-emitter voltage (t <sub>p</sub> < 5 ms)		±25	V
Continuous Collector Current	I <sub>C</sub>	T <sub>C</sub> =25°C	10
		T <sub>C</sub> =100°C	5
Collector Current Pulsed (Note 1)	I <sub>CM</sub>	20	A
Diode Forward Current	I <sub>F</sub>	T <sub>C</sub> =25°C	10
		T <sub>C</sub> =100°C	5
Power Dissipation (T <sub>C</sub> =25°C)	P <sub>D</sub>	38	W
Operating Junction Temperature	T <sub>J</sub>	-40 ~ +150	°C
Storage Temperature Range	T <sub>STG</sub>	-55 ~ +150	°C

Notes: 1. Absolute maximum ratings are stress ratings only and functional device operation is not implied.

Absolute maximum ratings are those values beyond which the device could be permanently damaged.

2. Pulse width limited by maximum junction temperature.

■ THERMAL DATA

PARAMETER	SYMBOL	RATING	UNIT
Junction to Case	θ <sub>JC</sub>	3.28	°C/W

■ ELECTRICAL CHARACTERISTICS (T<sub>C</sub>=25°C, unless otherwise noted)

PARAMETER	SYMBOL	TEST CONDITIONS	MIN	TYP	MAX	UNIT
<b>Off Characteristics</b>						
Collector-Emitter Breakdown Voltage	BV <sub>CES</sub>	I <sub>C</sub> =250μA, V <sub>GE</sub> =0V	650			V
Collector Cut-Off Current	I <sub>CES</sub>	V <sub>CE</sub> =650V, V <sub>GE</sub> =0V			5	μA
G-E Leakage Current	I <sub>GES</sub>	V <sub>CE</sub> =0V, V <sub>GE</sub> =±20V			±10	μA
<b>On Characteristics</b>						
Gate to Emitter Threshold Voltage	V <sub>GE(TH)</sub>	I <sub>C</sub> =250μA, V <sub>CE</sub> =V <sub>GE</sub>	4.5		7.5	V
Collector to Emitter Saturation Voltage	V <sub>CE(SAT)</sub>	I <sub>C</sub> =5.0A, V <sub>GE</sub> =15V	T <sub>C</sub> =25°C	2.0	2.5	V
			T <sub>C</sub> =125°C	2.4		V
<b>Dynamic Characteristics</b>						
Input Capacitance	C <sub>IES</sub>	V <sub>CE</sub> =25V, V <sub>GE</sub> =0V, f=1MHz		162		pF
Output Capacitance	C <sub>OES</sub>			30		pF
Reverse Transfer Capacitance	C <sub>RES</sub>			5		pF
<b>Switching Characteristics</b>						
Total Gate Charge	Q <sub>G</sub>	V <sub>CE</sub> =520V, I <sub>C</sub> =5.0A, V <sub>GE</sub> =15V		26		nC
Gate-Emitter Charge	Q <sub>GE</sub>			13		nC
Gate-Collector Charge	Q <sub>GC</sub>			6		nC
Turn-On Delay Time	t <sub>DON)</sub>	V <sub>CC</sub> =400V, I <sub>C</sub> =5.0A, R <sub>G</sub> =5Ω, V <sub>GE</sub> =0~15V, L=500μH		2		ns
Rise Time	t <sub>R</sub>			12		ns
Turn-Off Delay Time	t <sub>DOFF)</sub>			3		ns
Fall Time	t <sub>F</sub>			209		ns
Turn-On Switching Loss	E <sub>ON</sub>			0.16		mJ
Turn-Off Switching Loss	E <sub>OFF</sub>			0.13		mJ
<b>SOURCE- DRAIN DIODE RATINGS AND CHARACTERISTICS</b>						
Forward Voltage Drop	V <sub>F</sub>	I <sub>F</sub> =5.0A			2.0	V
Reverse Recovery Time	t <sub>rr</sub>	I <sub>F</sub> =5.0A, dI/dt=100A/μS, V <sub>CC</sub> =400V		52		ns
Reverse Recovery Charge	Q <sub>rr</sub>			148		nC

UTC assumes no responsibility for equipment failures that result from using products at values that exceed, even momentarily, rated values (such as maximum ratings, operating condition ranges, or other parameters) listed in products specifications of any and all UTC products described or contained herein. UTC products are not designed for use in life support appliances, devices or systems where malfunction of these products can be reasonably expected to result in personal injury. Reproduction in whole or in part is prohibited without the prior written consent of the copyright owner. UTC reserves the right to make changes to information published in this document, including without limitation specifications and product descriptions, at any time and without notice. This document supersedes and replaces all information supplied prior to the publication hereof.